

WORKING GROUP 1

The role of metaphors and images in the learning and understanding of mathematics

CONTENTS

| | |
|--|-----|
| The role of metaphors and images in the learning and understanding of mathematics <i>Bernard Parzys, Angela Pesci, Christer Bergsten</i> | 67 |
| Students interacting with an artefact designed to visualise three-dimensional analytic geometry <i>Christer Bergsten, Torbjörn Fransson</i> | 71 |
| Metaphors in mathematics classrooms: analyzing the dynamic process of teaching and learning of graph functions <i>Janete Bolite Frant, Jorge I. Acevedo, Vicenç Font</i> | 82 |
| Metaphors and gestures in fraction talk <i>Laurie D. Edwards</i> | 92 |
| A review of some recent studies on the role of representations in mathematics education in Cyprus and Greece <i>Athanasios Gagatsis, Iliada Elia</i> | 102 |
| Metaphorical objects and actions in the learning of geometry. The case of French pre-service primary teachers <i>Françoise Jore, Bernard Parzys</i> | 112 |
| Mediation of metaphorical discourse in the reflection on one's own individual relationship with the taught discipline: an experience with mathematics teachers <i>Angela Pesci</i> | 122 |
| Building visual structures in arithmetical knowledge – A theoretical characterization of young students' "visual structurizing ability (ViSA)" <i>Elke Söbbeke</i> | 132 |
| The effect of mental models ("Grundvorstellungen") for the development of mathematical competencies. First results of the longitudinal study PALMA <i>Rudolf vom Hofe, Michael Kleine, Werner Blum, Reinhard Pekrun</i> | 142 |
| A dyslexic child's strategies and images in arithmetic: a longitudinal study <i>Xenia Xistouri, Demetra Pitta-Pantazi</i> | 152 |

THE ROLE OF METAPHORS AND IMAGES IN THE LEARNING AND UNDERSTANDING OF MATHEMATICS

Bernard Parzysz, *I.U.F.M. d'Orléans-Tours, France*

Angela Pesci, *University of Pavia, Italy*

Christer Bergsten,¹ *Linköpings universitet, Sweden*

Between 15 and 20 persons have participated in the seven sessions intended for work group; the first five were devoted to discussing the nine accepted papers and the last two to the preparation of the final report. In order to work in an efficient way, the first sessions were divided into three parts, centered on particular themes :

- sessions 1 and 2 (*Pesci, Edwards, Acevedo*)² dealt more especially with metaphors
- session 3 (*Jore, Von Hofe*) was about the use of metaphors in the modelling process
- sessions 4 and 5 (*Söbbeke, Fransson, Xistouri, Gagatsis*) were centered on visualisation.

During the sessions some important points have been discussed and many questions raised. Here are some of them.

Through the various contributions of our group we could see that the word ‘metaphor’ was used with different meanings. Even if originally a metaphor has a linguistical nature, it is now used with a much broader sense : “*metaphor does not reside in words ; it is a matter of thought*” [Lakoff & Nuñez 1997]; for instance, “*diagrams on the blackboard, coloured blocks that kids use in representing battles or the raised eyebrow of an actor can all be considered metaphorical expressions*” [Barker 1987]³. The metaphorical discourse, connecting both hemispheres of the brain, is able to give a more profound dimension to the construction of knowledge (LeDoux, 1998).

Fundamentally, a metaphor can be seen as a correspondence between two domains : a source domain and a target domain. At the beginning, these two domains were linked (or at least the link was clear to everybody), but as time passed on the link sometimes disappeared. For instance⁴, ‘kite’ was first a word used to speak of a

¹ Four leaders were initially intended for preparing this working group: Bernard Parzysz, Angela Pesci, Moisés Coriat and Maciej Klakla, but unfortunately Moisés and Maciej could not attend CERME 4. We are most grateful to Christer Bergsten, from the organising committee, for kindly accepting to help us in this task.

² The names in italics refer to authors who presented a paper in the group; the papers will be found hereafter.

³ Quoted in [Pesci 2003].

⁴ This example was given by Julianna Szendrei.

special quadrilateral, referring to a concrete device, but it has now become the name of this quadrilateral, even for children who have never seen a kite and do not know what it is. This poses the question of what happens when a metaphor becomes a mathematical concept (i.e. when the target domain becomes detached from the source domain).

Pesci gives a list of metaphors which are very common in mathematics [Pesci 2003] : “*numbers as objects collections (...); zero as an empty box (...); addition as putting objects together (...); multiplication as a repeated addition (...); equation as a balanced couple of collections with a same weight ; (...) function as a machine which ‘takes’ a number, ‘works’ on it and produces another number.*” During the sessions, we could also see some examples of how concrete devices can be used as metaphors for mathematical concepts and the problems which may result (*Jore, Fransson*); we could also see and interpret children’s kinesthetic experiences and gestures⁵ as metaphors, such as ‘split’ (gesture of the hand) for fractions or tapping fingers on one’s cheek for counting (*Edwards*); we also saw that some gestures can only be evoked as ‘fictive motions’, e.g. when the graph of a function is considered as a point moving on it from left to right (*Acevedo*).

We could also see that metaphors and representations are used not only for communication purposes, but also that basically they can be considered as thinking devices intended for helping communication and thinking; thus it is in fact a tool for mental activity and not a didactical construct. Indeed, the metaphorical discourse as occasion for metacognitive reflection was exploited during experiences for mathematics teachers preparation (*Pesci*)

When using a metaphor with students, you try to reach something common to everybody (within the domain target), but it sometimes does not work, because they are not so familiar with this domain as you thought (*Acevedo*); moreover, all metaphors are inadequate in some way, because some features of the metaphorical object cannot fit with the theoretical object. For instance, integers constitute a ‘tacit model’ for any set of numbers [Fischbein 1989], which makes difficult for some students to understand that multiplication (resp. division) does not always produce a bigger (resp. smaller) number (*Vom Hofe*). In order to deal with such mismatches between teacher’s and students’ metaphors, it is important to study the relation between metaphors and mental models, as well as the limits of metaphors. This also implies the need to make students aware, for a given metaphor, of which elements are pertinent and which are not. In this view, a specific work has also to be undertaken with teachers (*Jore*).

More generally, the aim of representations is to develop abstract ideas. Experience shows that various modes of representation are in play in the teaching of mathematics, even in the study of a given mathematical concept : a given concept can be described through different types of representations: for instance (among many

⁵ A ‘gesture’ is intended for others, while a ‘kinesthetic experience’ is intended for one’s self.

others examples) decimal and fractional writings of decimal numbers, graphical and algebraic representations in analytic geometry. It is thus important to take a thorough interest in the relations between them, which leads to the notion of representation register, developed by Duval [Duval 2004]: it is a coherent system used for representing mathematical concepts; a register can be identified through three fundamental activities : recognise whether a given representation belongs to it or not, transform a representation into another within the same register (processing) and transform a representation into a representation of another register (conversion).

Among other subjects, we could see, through examples, the richness and variety of the ways used by students to interpret representations, an area which is still not much explored (*Söbbeke*); through other examples, we discussed on the fact that most students have difficulties to coordinate different registers and to move from one to another (*Gagatsis*), but also that an interplay between visual and symbolic representations could be promoted by having an artefact available in students' group work (*Fransson*). We had also a long discussion trying to understand the strategies and images used by a dyslexic child in arithmetic (*Xistouri*), a discussion which was still more interesting since one of the participants had been a dyslexic child.

But our purpose was also to propose guidelines for prospective work, and finally, during the last two sessions devoted to preparing the final report, several questions for future research were raised:

- 1- What are the characteristic metaphors, in use or possible, for different domain of mathematics? For different systems of representation?
- 2- How do metaphors and representations contribute to learning and communicating mathematical concepts? How does the way of using them influence the construction of mathematical concepts?
- 3- How can we facilitate students' passage from one type of representation to another?
- 4- Moreover, metaphors evolve through time. Can teaching have an influence on this change, and how?

Bibliography

- Barker, P. (1985): *Using metaphors in psychotherapy*. New York, Bruner / Mazel.
- Duval, R. (2004): A crucial issue in mathematics education : the ability to change representation registers, in *Proceedings of the 10th International Conference on Mathematics Education*, Copenhagen.
- Fischbein, E. (1989): Tacit models and mathematical reasoning, in *For the Learning of Mathematics 9*, pp. 9-14.

Working Group 1

- Lakoff, G., & Nunez, R.E. (1997): The metaphorical structure of mathematics, in L.D. English (ed.), *Mathematical reasoning: analogies, metaphors and images* (pp. 21-89). Mahwah, NJ: Lawrence Erlbaum Associates.
- LeDoux, J.: 1998, *The Emotional Brain*, Phoenix, Orion Books Ltd.
- Pesci, A. (2003): Could metaphorical discourse be useful for analysing and transforming individuals' relationship with mathematics ?, in A. Rogerson (ed.) *Proceedings of the 6th International Conference on Mathematics Education into the 21st century project, the decidable and the undecidable in mathematics* (pp. 224-230). Brno.

STUDENTS INTERACTING WITH AN ARTEFACT DESIGNED TO VISUALISE THREE-DIMENSIONAL ANALYTIC GEOMETRY

Christer Bergsten, *Linköpings universitet, Sweden*

Torbjörn Fransson, *Växjö universitet, Sweden*

Abstract: *To investigate students' ways of working with concrete materials in mathematics, a three-dimensional static artefact was constructed and made available to upper secondary students, with pre-knowledge only in two-dimensional coordinate geometry, for solving problems about planes and straight lines in space. Artefact interactivity was generally high, even students also disregarded the model to work only numerically with the coordinates, building on knowledge about lines in two dimensions. The model was used when trying to convince other students in the group.*

Keywords: *artefact, visualisation, concrete material, problem solving, analytic geometry*

Artefacts in mathematics education

The use of artefacts such as concrete materials to support mathematics learning is commonplace in primary education, though less common in upper secondary and tertiary education. Most research studies on the use of concrete materials in mathematics education have focussed on the effect on learning outcomes, often by experimental design comparing a treatment group and a control group (e.g. Sowell, 1989). Investigations of *how* students interact with such materials are more rare. As a consequence, we need more knowledge of how upper secondary students work with such materials, and of its influence on learning. For example, in the case of coordinate geometry in two dimensions, drawings on paper or a graphic calculator may serve the need of direct visual support for conceptual construction. However, in three dimensions, the direct experience of displacement in space of mathematical “objects” like straight lines and planes can be provided only by three-dimensional artefacts. This study investigates students' ways of working with such materials. We also give some introductory remarks on artefacts in mathematics education.

An artefact may be considered generally as any human creation, such as physical tools, production schemes, language or skills. Artefacts used for supporting learning, such as concrete materials designed for educational use, are ‘secondary’ as compared to ‘primary’ artefacts used directly in the production (Wartofsky, 1979). To make an artefact an ‘instrument’, for example for learning, it is necessary for the user to develop ‘utilisation schemes’, i.e. ways to use the artefact (see e.g. Strässer, 2004).

The focus of this paper is on how students interact with concrete materials used in mathematics education. Such artefacts may be classified according to different kinds

of criteria. Having the purpose of design in mind, concrete materials used in school are *common tools* or *educational materials* (Szendrei, 1996), where the former are everyday tools used in society for different purposes (such as matches or coins), in contrast to the latter being designed with the particular aim to be used in an educational context as an aid for learning (e.g. Cuisenaire rods). With regard to the character of the artefact itself, we distinguish between static, dynamic, and responsive artefacts. Examples of *static* artefacts are Cuisenaire rods and geoboards. Such artefacts can be manipulated but do not change or give any feedback to the user. An artefact is *responsive* if it has a mechanism to produce an output to the user's deliberate input request, e.g. a calculator. In a *dynamic* artefact, by a series of input responses a dynamic sequence evolves under the guidance of the user, as for example constructions in a dynamic geometry software by the use of 'drag mode'.

From the point of view of the utilisation scheme, a static artefact is open: it is up to the user to decide what to do with it. With a ball a child can play but also perform measurements to find its volume. For educational use the utilisation scheme must be constructed, or learnt by instruction. As a consequence, the didactic potential is also open. In contrast, a responsive artefact is more or less closed: when the user has given the input in a prescribed way, how the output is produced is out of his/her control. By combining open features of a static and closed capabilities of a responsive artefact, a dynamic artefact allows didactic activities of a guided discovery type.

In an overview of research about the 'effectiveness' of concrete materials in mathematics education, Sowell (1989) concluded that such materials may have a positive effect on learning and attitudes towards mathematics through long term use, provided that their use is properly handled by knowledgeable teachers (see also Suydam and Higgins, 1977; Thompson and Lambdin, 1994; Hall, 1998). However, it is also reported from seemingly well designed studies that no significant gain was found by the use of manipulatives (e.g. Resnick & Omansson, 1987; Bulton-Lewis et al., 1997). For some types of materials these results have been explained by a *Procedural Analogy Theory*, using an index to measure "the degree of isomorphism between the embodiment procedure and the symbolic procedure" (Hall, 1991, p. 122). For these types of artefacts, the index may measure what Szendrei (1996, p. 429) calls the "distance between concrete material and mathematical concept". Such a quantitative index, however, does not take into account the place of the activities within the curriculum and educational setting, the mathematical 'milieu', or the variation of utilisation schemes used by different students, even its design allows some flexibility.

An empirical study

The participants in our study were second year students in the science programme of upper secondary school in Sweden. They were familiar working with straight lines in two dimensions. In particular, they knew that the equation, $y = kx + m$, determines a straight line, where $k = \Delta y / \Delta x$ is the slope. They knew how to interpret the slope geometrically, and knew how to calculate the slope from given coordinates.

Six volunteering students formed two groups with three participants in each. In Group I there were three girls (here called Anita, Beata and Cilla) and in Group II one girl and two boys (here called Anna, Bo and Caj). The students had a model of a three-dimensional space available, made in the shape of a cuboid (see figure below). Four of its sides were made of a mesh of steel and the two other sides (top and bottom) were empty. The model was 16 squares wide, 20 squares deep and 27 squares high. Each square had sides of approximately two centimetres and the interior of the model was empty.

The students were engaged in a problem solving activity, designed for the transition from two- to three-dimensional coordinate geometry, working with a plane and straight lines in three-dimensional space. The focus of the study was to investigate

- to what extent students interact with the model;
- what students do when they interact with the model;
- how the interactions influence the solution processes.

The working sessions with the two groups were videotaped and the tape subsequently transcribed for the analysis. Each group had about one hour to work with the tasks.

The tasks

The purpose of the first task was twofold: to make the students acquainted with the model and begin to develop utilisation schemes, and to see how they would handle point descriptions in three dimensions. Three points were marked in the model, each located on an individual vertical edge. The task was to find a point, located on the remaining vertical edge, on the plane determined by the three given points. The students were also asked to describe, orally to a non-present person, the location of this point, with and without such a model available.

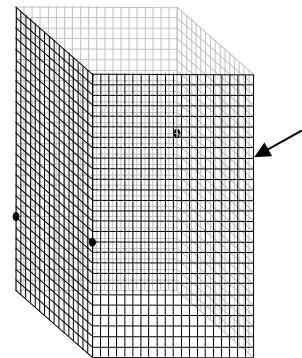

In the second task a straight line determined by two given points, located on two opposite sides of the model. The students had opportunity to visualise (a part of) this line, by connecting the given points with a piece of string. They were asked to identify some points on this line, with at least one point located outside the model. The tutor¹ introduced a coordinate system in the model, by placing three wooden sticks along three edges to represent the coordinate axes, marked as the x -, y - and z -axis. The points given in coordinate form were $(7, 0, 12)$ and $(15, 16, 20)$. In addition, the students were asked to decide which of five given points were on the line.

To analyse the second task, consider a straight line L and a point (x_0, y_0, z_0) on this line. To move from this point to another point on the line involves a movement in all three directions, as described by the formula $L: (x, y, z) = (x_0 + \Delta x, y_0 + \Delta y, z_0 + \Delta z)$. We may interpret the movement as a move in one direction at a time, for example Δx

¹ The tutor at the sessions was the presenting author of this paper. The group of students were most of the time by themselves, the tutor making only short visits to see how work was proceeding.

steps in the x -direction followed by Δy and Δz steps in the y - and z -directions, respectively. The model supports this interpretation, as the students are able to look at the line through the xz -plane and the yz -plane, and by this also see the projection of the line on these planes. However, since the students have not been working in school with straight lines in dimensions higher than two, we can't expect them to use the symbolic representation of the line given above. Considering their background knowledge, they may try to calculate a slope. Here they have to realise the fact that a three-dimensional line has different slopes in different directions. The model may support the students to calculate two slopes, one that they can visualise in the xz -plane and one in yz -plane, k_x and k_y , respectively. For the given line these are $k_x=1$ and $k_y=0.5$. With these, the students could be able to determine the coordinates for an arbitrary point on the given line, using $\Delta z = k_x \Delta x$ and $\Delta z = k_y \Delta y$.

The model also supports a direct three-dimensional interpretation of representing the movement from one of the two points to the other in terms of a vector $(\Delta x, \Delta y, \Delta z)$. Just by counting squares they can determine $\Delta x=8$, $\Delta y=16$ and $\Delta z=8$. Further, using proportionality, they may scale $(8, 16, 8)$ down to $(1, 2, 1)$, which they may relate to the model, and may further be able to combine several vectors $(1, 2, 1)$ to reach new points. In this case, they are essentially working with the line in parametric form, $L: (x, y, z) = (x_0, y_0, z_0) + t(1, 2, 1)$.

Working with the plane

During the first task, Group I used much time to read and look at the instructions, before any attempt was made to interact with the model. It was apparent that the task and/or the concept of a plane seemed unclear to the students. Then Beata points at the model, explaining how the plane must be situated and where the fourth point must be. This is the start to a more intense interactivity with the model by all members of the group, and Beata is counting units on the grid model by touching it with the fingers:

Beata: *...leaning this much on this side it must lean the same on that side? Or what do you say?..1, 2, 3, 4, ...*

Anita goes on and does the counting to finally mark the point, Cilla still looking at the definition of a plane in the text, seemingly unsure about what a plane is. Then they are looking back at the model and end their solution process:

Anita: *Yes but it should be like that ... it is the same difference here [referring to their counting]*

The group spends more time for the task of explaining to a non-present person where the fourth point is. During this process there is much conversation about how to talk to that person, sometimes using fingers to count on the model, two of the girls still unsure about the concept of a plane. Anita wants to use a string between the points to be sure, and stands up to put it there but they decide it is not necessary. When they try to explain to a person who does not have the model available, Beata says:

Beata: *It is difficult when you don't have this model.*

They are looking for appropriate ways to describe it, using words like net, rectangle, cube, and so on, giving the number of units to count. During this part of the session there is almost no interaction with the model.

The students in Group II spend only a very short time reading the problem text. Caj starts looking at the model while the others are reading, then counts on the vertical axes to finally hold a finger at a point indicating his solution, and goes on to explain his thinking. Bo then takes a sheet of A4 paper holding it inside the model to explain what a plane is, indicating that Caj has not found the correct point. The students again look in their papers, and Bo holds his sheet of paper for demonstration:

Bo: .. *it is leaning like this...*

When Anna starts talking about the lines that she can ‘see’ between the points, Caj asks for some sticks to insert in the model. The tutor supplies a piece of string, which Anna and Bo put into the model between two points (P and Q) on one side, and between two points across the diagonal (Q and R). Bo then holds a string from P towards the fourth axis, above the string between Q and R until it touches this string. This way the fourth point is found on that axis. Anna counts grid units in the model, using her fingers, to describe where the fourth point is located in relation to the given points, in order to answer the task of explaining the solution to a non-present person. The students do not complete the task of explaining without the model available.

Working with the line

When the tutor is introducing the coordinate axes, Group I has some questions on how it works. Beata is explaining to the others, as regards for example the order of the variables in the coordinate notation. The students stand up around the model and count (slowly) with their fingers on the grid to mark the two given points. The tutor offers the string, which they use to mark the line between the two points. While all focus on the model to understand the task to find a point on the line outside it, Beata introduces the strategy of thinking about how much the line continues for each x -step, pointing with her hand. During a rather silent period all girls are looking at the model, but when Beata starts writing on the paper the others also look at her paper.

Cilla : *Okay, shall we describe points on this line then?*

Beata : ... *it must lie outside the model... at least one.*

Cilla : *So the line that continues here, then?* [she makes an expansion of the line with her hand.]

Beata: *Yes... Shall we see how much it continues in that direction* [she points in negative x direction] *for each x -step?*

Here Beata looks at the y and the z , one at a time, and tries to find out how much they change for each change of the x coordinate. Later in the discussion she goes on:

Beata: *Is it possible to assume that... x equals... in a way so that we can write down a formula? From here to there it was seven, [location of the point (7,0,12)] x_1 is equal to seven here... then y equals* [inaudible]

[Beata writes on a sheet of paper: $x_1 = 7$ $x_2 = 15$ $y_1 = 0$ $y_2 = 16$ $z_1 = 12$ $z_2 = 20$]

Cilla: *Mmmm* [agrees]

Beata: *So it has moved eight steps here... There it has moved sixteen steps [inaudible] ... z is proportional to x or they are the same.*

Anita: *And y is twice as much.*

When Beata looks at the model the other girls still look at what she has written on the paper, with the new point (8, 2, 13). It is Beata who is intentionally interacting with the model, as is observed when she is turning it to look from another angle, causing the others to look up from the paper. Beata is pointing in the model to explain her reasoning. At this occasion the discussion touches the equation of a line in two dimensions, but they decide to leave that since an equation is not asked for. However, they use the idea of the proportional relation between the variables of the equation, later writing down $\Delta x = 2\Delta y$ (but using the correct relation in their reasoning). When checking up the change for z , Beata puts the model with a vertical face down. At some few occasions during the rest of the session, the students look/point at the model but most of the time focus is on what is written on the paper. During the last five minutes, completing the second task, the girls pay no attention at all to the model, reasoning only numerically from the given coordinates.

The Group II students seem to have no problem to understand the coordinate system in three dimensions, placing the two given points and fixing a string between them to indicate the line. After being silent for a while, looking at the model, Anna suggests:

Anna: *Shouldn't we be able to calculate some k-value?* [She asks the boys.]

Bo: *There is one slope in one direction and another in another direction.* [Bo pointing with his hand in two different directions.]

Anna: *But one should...*

Caj: *You are thinking two dimensions.* [And Caj suggests:]

Caj: *You may see it like two straight lines, one line here...* [pointing at a side of the model]

So far, the interaction with the model is just pointing out directions. But, to calculate the slopes, Anna and Caj now visually project the point at the plane $y=16$ to the plane $y=0$. When doing that they immediately determine the slope to be 1, interacting with the model by counting, pointing and marking a point.

Caj: *Now we take a line between these [(7,0,12) and the projected one at (15,0,20)]*

Anna: ... [visualising the slope with a pen] *The k-value is one, one can see that.*

To calculate the slope in the yz -plane they just count² grid units in the z - and y -direction respectively, and determine the slope to be 0.5.³ There is a lot of pointing and looking at the model. Anna, pointing with her pen to the interior of the model, suggests that they should have a string through the model and just count to see what point it is. Instead they start looking for a formula to solve the problem, working with

² Bo and Caj share the work in interacting with the model by counting one direction each simultaneously.

³ With this information of the two slopes the students could have determined other points on the line.

an expression of the type $z=k_1x+k_2y+m$, where $k_1=1$ and $k_2=0.5$. They find⁴ that $z=x+5$ for $y=0$ and arrive at $z=0.5y+x+5$. Choosing $z=15$ (between 12 and 20 for the given points) they try to decide x and y from the formula⁵ but arrive at a strange result⁶. Then after one minute of silence Anna says:

Anna: *But wait a minute, then it's minus ...this point we have [points at the given point (7,0,12)] this is 7 0 12 isn't it?*

Bo: *Yes we got one point.*

Anna: *Yes, y decreases so it will be -0.5, x also decreases ...6,0.5, 11 it is. Then we have a point on the line outside of the model...then we just add here when x is 8, we get..*

Bo: *Yes, that's also one way to solve it. It doesn't matter how we solve it, or? Then we could have continued the string like that from the start and just looked.*

When working with the final task, i.e. decide if the five given points are on the line, Anna discovers their mistake when she looks at the given coordinates.

Anna: *But here you have...x is 15...then x has increased to 23... [...] then it increases by 8.*

Caj: *So x is equal to z minus 5...that works, doesn't it?*

Anna: *y is to...y is to...but it isn't correct...then we did wrong here, y must decrease by 2.*

Discussing their previous calculations, Anna has understood their mistake and explains to the others by referring to the model, using a pen to visualise the slope, how the steps must be counted. After that she corrects their answers for the task of finding some points on the line to be (6, -2, 11) and (8, 2, 13). By these explanations, Bo and Caj also realise how things work:

Anna: *8 and 2 it is the same...yes, and then it is correct that (23, 32, 28) is on...*

Bo: *One need to look only at the relationships between...*

Anna: *Yes, it is the relationships between...*

Subsequently, they easily solve the rest of the task only by reasoning from the increments of the coordinates, with no interaction at all with the model.

Analysis

The artefact used in this study is *static* in the classification above. The students were not instructed by the tutor how to use it for their problem solving session, and thus had to develop their own utilisation schemes. By the grid construction it was 'natural' to count the grid units as a way to describe point locations on the artefact, a utilisation scheme that all students used. Other mathematical objects, such as the plane and the line involved in the tasks, had to be inserted in the model by an intentional act. Here a conceptual basis was observed to interfere with the model interaction, in the case of the plane as a problem to understand the task for Group I –

⁴ Anna is here using the string inserted the model to continue the projected line in the xz -plane until it intersects the z -axis.

⁵ They see this formula as the equation of the line, by a generalisation from the two dimensional case.

⁶ Anna is saying, for example: *But there are two k-values, that is what is so stupid.*

the development of utilisation schemes was constrained by this weak conceptual grasp. For Group II the concept of a plane was visualised by one of the students inserting a paper into the interior of the model, and the image of a plane was also present in the solution process of task 1 using strings to represent crossing lines on the plane. Here the static artefact opened up for creativity in developing utilisation schemes. The idea of a straight line in a coordinate system was already well known in two dimensions from the students' earlier studies, and there was no conceptual problem with the line, as observed from the interactivity with the model, both groups taking the advantage of inserting the piece of string available to represent lines.

The student-artefact interactivity differed considerably between the two groups, even some commonalities can be observed. In the first task, Group I students were sitting much longer reading the problem texts before turning their attention to the model, as compared to Group II. One explanation to this may be the observed weak conceptual idea of what a plane is, without which the static model (not including a plane) may not seem to offer much help. However, the first solution attempts were similar between the groups, counting with the fingers touching the grid units on the model. In both cases one of the students presented interactively with the model this way of looking at the problem, without first discussing it with the peers. This way of using the model to share or discuss ideas with peers, could be observed throughout the working sessions. It was also stated explicitly by Beata that it was difficult to explain the solution without the model available.

After the solution to task 1 was found, there was in Group I not much interactivity with the model, and the girls spent much time with no attention at all to the model discussing how to present the solution to a non-present person. However, the students in Group II developed an extended utilisation scheme with the artefact, after showing visually, using a sheet of paper to represent the plane, that the first proposed solution could not be correct. Instead they inserted strings in the model for lines between the given points, and this way *constructed* (approximately) the target point of the problem, by manipulating the artefact. Then again, to describe the location of the point, the 'old' utilisation scheme of 'finger counting' the grid units was used. This interactivity with the model also seemed to function as a post-validation of the solution.

During the work with the line, all students in Group I interacted with the artefact in the beginning, standing up around the model to mark the given points and line. However, the solution process was dominated by one of the students, Beata, who suggested to look at how the line continues with each 'x-step'. She proposed this idea after focussing her eyes on the model, which may suggest that it was visually influenced by it. The participation of the other students appeared to be only in response to Beata's activity. It was she who was seen to interact actively with the model, pointing to explain her reasoning, turning it or putting another face down on the table, to look from another angle. When the proportional change of coordinates had been seen as a way to solve the problem, the interactivity with the model stopped

completely, and the students worked only with pen and paper for five minutes without looking at it.

Group II developed a more rich utilisation scheme with the static artefact also when working with the line task. By focussed interactivity with the model from all students in the group, the search for a k -value (slope) for the line, originated from their knowledge in the two-dimensional case, the idea of a projection of the line (segment) onto the coordinate planes was followed up and completed correctly by instrumental work with the model. To visualise the projected line segments a pen, held close to the faces of the model, was used. However, by over-generalising from the two-dimensional case, they directed their work towards finding an equation for the line, using the two k -values and the intercept of one axis, and from a chosen z -value use this equation to calculate the other coordinates. This work also led to more interactivity with the model, but after a 'strange' result from their algebra they seemed to abandon the equation⁷ and look at the problem text again. It was then that the idea to look only at the increments of the coordinates came to Anna, confirmed also by Caj's reference to the model for the relation $z=x+5$. This new focus on the coordinates made Anna realise they had made a mistake with the change of the y -coordinate. She explained to the others, by showing on the model with a pen to visualise the slope, how to count the steps. Again, similar to Group I, they now solved the last part of the task by considering only the increments of the coordinates, without referring any more to the model in what they were saying or doing.

Discussion and conclusions

It is difficult to trace the genesis of the solution that the students found to the line problem. The work started by looking at and interacting with the model, in different ways, but the final insight seems to have come when they looked only at the given coordinates for different points on the line. It is possible that with a focus from the start on the numerical relations between and within the coordinates, the students would have solved the problem also with less attention to the model. However, it seems likely from the analysis of this problem solving session, especially for Group II, that their interactivity with the static artefact played an important role in building up a sense of understanding or control of the problem situation, through the images evoked by the focus on different parts and aspects of the model. Now, the exact coordinates for points not located on the grid faces of the model are impossible to find by only looking at the static model: for this a logical analysis is needed. The analysis with the projections, as done by the students in Group II, allowed this, but was not used for this purpose.

It was also observed that the model was much used as a vehicle for communication when a student wanted to explain some idea to the other students in the group. After working with the model, mentally or physically, this is only to be expected. The fact

⁷ Anna seems to feel more confident with the model, saying at this occasion: *I propose we take a string and drag it straight through.*

that the students were sitting at three different sides of the table where the model was placed should also be noted. The coordinate system was thus seen from different orientations, which may have influenced the effect that the visualisation process had on the understanding of projections and change of coordinates along the line.

It can be observed how the knowledge students bring into the problem situation is, at least partly, guiding the interactivity with the artefact. Working with the first task on the plane, two students in Group I showed uncertainty about what a plane is, and they showed no intention to interact with the model on this task, possibly because they then did not know how to take advantage of the model, until the third student had demonstrated how the plane must be located. In contrast, the students in Group II did not hesitate to take advantage of the model, also to visualise what a plane is, and their solution was a direct result of the interactivity with the model. Also, during the work with the line, Group II directed their efforts to find the equation for the line and use that to solve the problem, possibly because this was how they had worked in the two-dimensional case they were familiar with. Since the static artefact is didactically open, it allows students to (try to) develop utilisation schemes to pursue their ideas of how to solve the problem, using the model at hand.

In this case study we have described some patterns of interactivity with a static artefact. Not only the model itself but also the educational setting and its place in the curriculum, and the utilisation schemes developed by the students, guide its didactic potential. For fruitful utilisation schemes to develop, appropriate pre-knowledge structures in students need to be activated. When students integrate such schemes with visual, numerical and algebraic modes of reasoning, and all students in a group work setting are actively involved in the interactivity with the static artefact, it has a didactic potential to support a mathematical discussion directed towards understanding. Another strength of having the artefact available is that it supports, by the visualisation it affords, the validation phase of the solution process.

References

- Bulton-Lewis, G., Cooper, T., Atweh, B., Wills, L. & Mutch, S.: 1997, 'Processing load and the use of concrete representations and strategies for solving linear equations', *Journal of Mathematical Behavior* 16, 379-397.
- Hall, N.: 1991, 'A procedural analogy theory: The role of concrete embodiments in teaching mathematics', in F. Furinghetti (ed.), *Proceedings of PME 15*, Vol. II, Assisi, Italy, pp. 117-124.
- Hall, N.: 1998, 'Concrete representations and procedural analogy theory', *Journal of Mathematical Behavior* 17, 33-51.
- Resnick, L. & Omansson, S.: 1987, 'Learning to understand arithmetic', in R. Glaser (ed.), *Advances in Instructional Psychology*, Vol 3, Erlbaum, Hillsdale, NJ.
- Sowell, E.: 1989, 'Effects of manipulative materials in mathematics instruction', *Journal for Research in Mathematics Education* 20, 498-505.
- Strässer, R.: 2004, 'Artefacts – instruments – computers', in C. Bergsten et al. (eds.), *Mathematics and Language. Proceedings of Madif4*, Malmö, Sweden, pp. 212-218.
- Suydam, M. & Higgins, J.: 1977, *Activity-based learning in elementary school mathematics: Recommendations from research*, ERIC, Columbus.

Working Group 1

- Szendrei, J.: 1996, 'Concrete materials in the classroom', in A. Bishop et al. (eds.), *International Handbook of Mathematics Education*, Kluwer, Dordrecht, pp. 411-435.
- Thompson, P. & Lambdin, D.: 1994, 'Research into practice: Concrete materials and teaching for mathematical understanding', *Arithmetic Teacher* 41, 556-558.
- Wartofsky, M.W.: 1979, *Models. Representation and the Scientific Understanding*, Reidel, Dordrecht.

METAPHORS IN MATHEMATICS CLASSROOMS: ANALYZING THE DYNAMIC PROCESS OF TEACHING AND LEARNING OF GRAPH FUNCTIONS.

Janete Bolite Frant, *Pontificia Universidade Católica de São Paulo, Brazil*

Jorge I. Acevedo, *Universitat de Barcelona, Spain*

Vicenç Font, *Universitat de Barcelona, Spain*

Abstract: *The purpose of this paper is to analyse a phenomenon that is observed in the dynamic process of teaching and learning of graph functions in high school¹: the teacher uses expressions that suggest, among other ideas, (1) orientation metaphors, such as “the abscise axis is horizontal”, (2) fictive motion, such as “the graph of a function can be considered as the trace of a point that moves over the graph”, (3) ontological metaphors and (4) conceptual blendings.*

Keywords: *metaphors, graph, function*

1 INTRODUCTION

In this research we have tried to answer the following four questions: What type of metaphors does the teacher use to explain the graphic representation of functions in the high school? Is the teacher aware of the use he/she has made of metaphors in his/her speech and to what extent does he/she monitor them? What effect do these metaphors have on students? What is the role played by metaphors in the negotiation of meaning?

This paper is divided into five sections. The first section contains an introduction and comments on the research problem. The second section reviews the research on metaphor and presents the theoretical frameworks of embodied cognition. The third section presents the study and its methodology. The fourth section contains the data analysis and our answer to the four questions that are the goal of the research. Finally, in section five, we offer some conclusions.

2. BACKGROUND

In recent years, several authors (e.g., Font & Acevedo 2003; Johnson, 1987; Lakoff & Núñez, 2000; Leino & Drakenberg, 1993; Núñez, 2000, Presmeg, 1992, 1997; Sfard, 1994, 1997) have pointed out the important role played by metaphors in the learning and teaching of mathematics.

We start by considering metaphor as an understanding of one domain in terms of another. According to Lakoff and Núñez (2000), metaphors generate a conceptual relationship between a source domain and a target domain by mapping and preserving

¹ Bachillerato in Spain

inferences from the source to the target domain. Because metaphors link different senses, they are essential for people in building meanings for mathematical entities "...a large number of the most basic, as well as the most sophisticated, mathematical ideas are metaphorical in nature" (Lakoff and Núñez p. 364). However, not all conceptual mappings draw from direct physical experience, or are concerned with the manipulation of physical objects. We are also aware that only some aspects of the source domain are revealed by a metaphor and in general, we do not know which aspects on the source domain are mapped by the students.

Although conceptual metaphor is directly related to the person building it, in classrooms, teachers use a metaphor, consciously or otherwise, to try to explain a mathematical subject to students more clearly, i.e., in order to facilitate students' understanding. We investigate the implications of this practice for students' understanding of mathematics.

3 METHODOLOGY

The research presented here is a theoretical reflection based on analysis of various teaching processes for the graphic representation of functions in the Spanish high school diploma. The classroom episodes and interviews mentioned in this paper are part of the field material used as the basis for the reflections and results shown here.

The information was obtained at the place of work of the subjects researched. The teachers who participated in this research did so voluntarily and gave their specific consent to interference with their teaching work (class observations, video recording, analysis of working materials, etc.). The students participated at the teacher's request. The choice of the teachers and students recorded on video was not made based on any statistical criterion. Only their willingness to co-operate and to be recorded was taken into consideration.

In this paper, we are going to look especially at the recording of the classroom sessions of teacher A. Two other teachers (B and C) are also referred to, as is the interview, recorded on video, with a student of teacher C, who we will refer to as student D.

In order to analyse the teachers' teaching processes effectively, we need written texts. For this reason, we videotaped his lessons and transcribed them. We organised the transcription into three columns. These were (1) transcriptions of the teacher's and students' oral discourse, (2) The blackboard and (3) comments on the teacher's gestures. Our focus was on the teacher's discourse and practice, so the students' discourse and practice² appears only when interacting with the teacher.

² We feel that mathematics learning means becoming able to carry out a practice, and above all, to perform a discursive reflection on it that would be recognised as mathematical by expert interlocutors. From this perspective, we see the teacher's speech as a component of his professional practice. The objective of this practice is to generate a type of practice within the student, and above all, a discursive reflection on it, which can be considered as mathematics.

Once we had these written texts, we needed to separate them into analysis units. One possible way to perform this separation was to take the construct “didactic configuration” as the basic analysis unit. Godino, Contreras and Font (2004) consider that a *didactic configuration* – hereinafter referred to as a DC – is established by the teacher-student interactions based around a mathematical task.

The teaching process for a mathematical subject or contents takes place in a timeframe by means of a sequence of didactic configurations. Although the basic criterion for determining a DC is the performing of a task, grouping in didactic configurations is flexible and at the researcher's discretion.

Analysis of the didactic configurations implemented in a teaching process is facilitated if we have some theoretical models for use as reference. Godino, Contreras and Font (2004) mention four types of theoretical configurations that can play this role and which are designated as *teacher-centred*, *adidactic*, *personal* and *dialogue-based* configurations. The empirical didactic configurations that arise in the teaching processes carried out are indeed close to one of these four theoretical configurations.³

Division of the classroom session into didactic configurations enables subsequent macroscopic analysis of a wide range of didactic configurations, while finer (microscopic) analysis will be carried out mainly on a much smaller number of these didactic configurations. In our research, after defining a DC, we focused our analysis on the phenomena related to the use of metaphors seen in it.

4 DATA ANALYSIS

In this section, we will perform the data analysis and answer the four questions that are the objective of the research

4.1 Reply to the first three questions

As far as the first question is concerned, the use of *orientation metaphors* can be seen in the teachers' explanations. For example, we can see that teacher A is using “horizontal” instead of saying “parallel to the abscises axis”, “horizontal axis” instead of “abscises axis” and “vertical axis” instead of “ordinates axis”. This is stressed not only in his speech, but also in his gestures. Only in one DC did the teacher fail to identify the ordinates axis as the vertical axis and the abscises axis as the horizontal axis although interestingly, the text book never made this identification.

Teacher A: ...in $x = 0$ shows a minimum and the derivative in $x = 0$ is zero as we could expect, because now the tangent line is horizontal... [While he says this, he gestures with his hands, indicating the horizontal position of the tangent line on the graph on the blackboard]

³ The lack of adidactic DCs and the presence of some dialogue-based DCs in the classroom sessions recorded on video, seems to suggest that they are quite similar to the traditional mathematical classroom - featuring one blackboard, one teacher as the focus of discussion and twenty to thirty silent students which seems to belong to history.

We can find also metaphors which facilitate students' understanding of the idea that "the graph of a function can be considered as the trace of a point that moves over the graph".

Teacher A: ...if before 0 is increasing, if after 0 is increasing, if before 0 and after 0 is increasing we have an inflexion point. If before 0 is increasing and after 0 is decreasing, it's a maximum. If before 0 is decreasing and after 0 is increasing, a minimum. [Gesturing comes along these comments in the graph of the blackboard].

In the teacher's discourse, we find a powerful metaphor, *the fictive motion* (Lakoff and Núñez 2000). He, teacher A, uses expressions like "before 0" and "after 0" in such a way that the point 0 is understood as a location determined on a path (function). According to the authors, this is ubiquitous in mathematical thought (p. 38). There is a spatial organisation, suggesting an origin (from), a path (where the function goes) and a goal (to, until). The essential elements in this schema: are a trajectory that moves, a route from the source to the goal, the position of the trajectory at a given time.

Font (2000) and Bolite Frant et al. (2004) found that when teachers explained a graph of a curve as the trajectory of a point that moves, the students thought point A would be the same after being moved, as when a person or a car moves from one place to another in space, they are still the same person or car. Here we see that for the teacher, only part of a source domain from daily life (things moving in space) was mapped, while the students were mapping a bigger scene. In other words, teacher has a clear idea of what features were to be mapped while the students do not.

Another type of metaphor observed are *ontological* - which enable events, activities, emotions, ideas, etc. to be considered as if they were entities (objects, things, etc.) - and *metaphorical blends*. For example, a mixture of ontological and dynamic metaphors can be seen in the following transcription from teacher A.

Teacher A: One of the things we study to representing the graph of a function is the behavior at the infinity. What does the function do when x tends to infinity? What does the graphic of a function do when x tends to infinity? It could do this, going towards positive infinity [while drawing the left-hand graph]. It could do this, going towards negative infinity [he draws the centre graph on the previous graph]. It could also increase and stabilise until a certain number, like this [he draws the right-hand graph over the graph in the centre. In the three graphs the teacher moves his hand, making movements that are a continuation of the part of the graph drawn, suggesting an indefinite continuation].

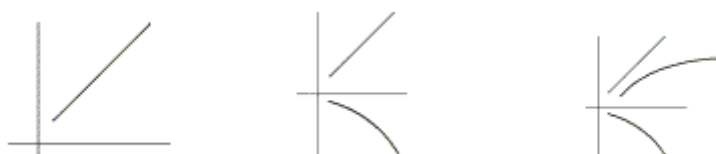

In order to answer the second question, a semi-structured interview with the teachers

took place, which was also video recorded. The teachers' level of awareness of their use of dynamic metaphors and their possible effect on students' understanding differs from teacher to teacher. The teacher who gave the class we have used so far, teacher A, was more aware than others. However, Font and Acevedo (2003) consider the case of teacher B, and it can be seen that he is not aware that he uses dynamic metaphors and, therefore does not control them. As a consequence of the interviewer's questions, teacher B realises that he uses them, but feels that this use facilitates understanding and does not feel that the possible difficulties that they may cause his students are important. In fact, he feels that the use of metaphors does not lead to any type of conceptual error among his students.

In order to answer the third question, various students were interviewed and recorded on video, questionnaires were also given to some students and some of the students' productions during the teaching process (for example, examinations) were analysed. A significant example is the case of one of teacher C's students, who had a good command of the graphic representation of functions. This student was asked to comment verbally on the prior steps (domain; cuts with axes; asymptotes and behaviour at the infinity; study of maximums, minimums, increasing or decreasing intervals; study of inflection points and concavity and convexity intervals) and construction of the graph in the examination. Both the graph and the steps prior to his examination answer were correct.

While no metaphor was observed in his written answer, they were omnipresent in his explanation of how he had constructed the graph. For example, in response to the question "Can you now tell me when the function will be increasing and when it will be decreasing?" the student correctly answered by pointing to the intervals and saying that "it increases here because it goes up and decreases here because it goes down.")

Interviewer: Can you now tell me when the function will be increasing and when it will be decreasing? [While putting the paper on which the student has drawn the graph of the function in its horizontal position].

Student D: [Hesitates for a few seconds] I don't understand, do you mean that the axes have changed?

Interviewer: No, the axes haven't changed, they're still the same.

Student D: This one is decreasing because it is going down and this one is increasing because it is going up, this other one is decreasing because it is going down and this one is increasing because it is going up. [He hesitates for a few seconds and points to the part of the curve shown with a thin arrow as increasing and that shown with a thick arrow as decreasing]

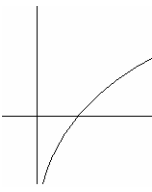
| | | |
|--|--|---|
| <p>S: -1</p> <p>T: Then the domain is real numbers except for -1, that is, you can find an image for any number except for -1</p> <p>T: There are more complicated functions, such as the neperian logarithm of x, for example.</p> <p>T: What is the domain of this function? Think about the graph and from there.... Tell me.</p> <p>S: From zero to positive infinity.</p> <p>T. Yes, from zero towards positive infinity is the domain, because logarithms of negative numbers do not exist, the logarithm of minus one does not exist. Is zero included or not included?</p> <p>S: No</p> <p>T: No ...very good... So the domain of this function is from zero towards positive infinity. Remember that the graph of this function, did something like this,.. The graph of this function did something like this, and the domain is from zero towards positive infinity.</p> <p>T. Any doubts?</p> <p>T: A final example, the square root of x, What is the domain of this function?Come on!!</p> <p>S:...(inaudible, but it is an incorrect answer)</p> <p>T: Ah yes!</p> <p>T: Except for the negatives ... because the square root of a negative number does not exist, we could also say the same real numbers except for the negatives, easier, all the positive numbers, we can put it like that, easier, we can express it in the form of an interval, from zero to infinity, zero is included this time, it is included.</p> | <p>$f(x) = \ln x$</p> <p>$D(f) = 0, +\infty)$</p>  <p>$D(f) = (0, +\infty)$</p> <p>$f(x) = \sqrt{x}$</p> <p>$D(f) = [0, +\infty)$</p> | <p>Teacher writes on the blackboard “$D(f)=0,+\infty)$”. He points to zero with the fingers.</p> <p>Teacher writes on the board “(“ before the zero</p> <p>The teacher draws the graph and points to it. with the hand</p> <p>The teacher gestures with his hands following the line of the graph. Then he points to the zero, and moves it towards the right to represent the interval $(0, +\infty)$.</p> |
|--|--|---|

First the teacher introduces the formulation “the domain is the set of values of the independent variable that has an image”. Then he continues: “they are the values from which I can find the image”. The second remark is more functional in finding the domain than the first; since it facilitates a “language game” that allows a common meaning about which the domain in question is. The characteristics of this “language game” for the function $f(x)=1/(x+1)$ are: 1) *Introduction of a generic element*. The

teacher introduces the element x which allows operation of the function formula according to “when I substitute the x (his finger is on the x in the given formula) for these numbers I can carry out this entire calculation (with his hands surrounding the fraction $1/(x+1)$), that is, I can find the image”. Then he waits for the students to mentally find the values for which the operations indicated in the formula of the function cannot be carried out. 2) Agreement of the range of values of the generic element. The students raise some hypotheses about the domain until they came to an agreement that was accepted by all, including the teacher. Several students say “-1” and the teacher is satisfied with this answer.

In the function $f(x) = \ln x$, the same language game is reproduced, with certain differences. The first is that the generic element is a point in the negative part of the abscises axis. The teacher draws the graph of $f(x) = \ln x$ and waits for the students to mentally apply the following technique: (1), thinking of a negative point; (2) tracing a line perpendicular to the abscises axis passing through this point; (3) observing that this line does not cut the graph of the neperian logarithmic function and, (4) stating that this reasoning is valid for any negative point and also for a point in the origin (this technique was shown in a previous unit). The second difference is that, when the students answer “from zero to positive infinity” the teacher considers it to be ambiguous and decides to intervene, asking them if zero is a point of the domain; he then accepts the students’ answer that zero is not the domain.

It is important to note that both answers is expressed in metaphorical terms. Students and teachers use the expression “from zero to positive infinity”. The students do so orally and the teacher adds a written expression $(0, +\infty)$ and gestures towards the positive part of the abscises axis (moving his hand from the origin to the right. This is the metaphor that considers the semi-line number as a path with a source (start point) and a goal (positive infinity).

The synchronism of dynamic language and hand movement allows students to understand the domain, a case of actual infinity, since it is an open interval, as the result of a movement that has a beginning but no end. According to Lakoff and Núñez (2000 p.158), we see this case of actual infinity as the result of a movement that has a beginning and no end, due to the fact that we metaphorically apply our knowledge of processes which have a beginning and an end to this type of process. This is what these authors call the BMI – the Basic Metaphor of Infinity.

5 FINAL CONSIDERATIONS

This paper revealed that conceptual metaphors are relevant tools for analysing and improved understanding of mathematics classroom discourse. In one way it is already embedded in theoretical concepts -e.g. the values above the origin (the ordinates axis) are positive. In the other, it is present in teacher’s explanation when for in order to facilitation purposes, in order to turn theoretical concepts into intuitive ones, he used metaphors that may relate directly to students’ daily experience - e.g. the vertical axis

as the ordinates axis. It is also present in the way students organise their knowledge – e.g. of the Cartesian axis based on spatial orientation based on their bodies.

We found that the use of several metaphors (orientational, fictive motion, ontology, and metaphorical blends) is present in both the teacher’s and students’ speech. This is inevitable and sometimes unconscious, but it is fundamental in building/talking mathematical objects.

As well as a description in global terms, the graphic representation of functions also requires the introduction of local concepts such as increasing and decreasing at a point, etc. formulated precisely in static terms, using the notion of number sets. These local concepts are very difficult for high school students, and for this reason many teachers leave them in the background and prefer to use dynamic explanations, in which the use of dynamic metaphors is fundamental, which they consider more intuitive. Students' productions also show that the use of these metaphors in the teacher's speech has significant effects on students' understanding.

Metaphors, as seen here, also play an important role in negotiating meaning in classrooms, and we propose a model that takes the dynamic of the interplay of discourses into account. It is important to note that metaphors in classrooms may have two different directions. On the one hand, there are metaphors that teachers use in the belief that they are facilitating learning, and on the other there are students’ metaphors.

The teachers’ source domain is mathematics and the target is daily life because they try to think of a common space to communicate with the students. However, the domain of daily life is not always the same for both, because the teacher is using only the part of the daily life concept that is mapped into the mathematical domain. Students usually have a larger daily life domain than that which is mapped and is not in the same mathematical teacher’s domain.

The use of metaphors has its advantages and disadvantages. The teacher must therefore make a controlled use of them and must be aware of their importance in students’ personal objects.

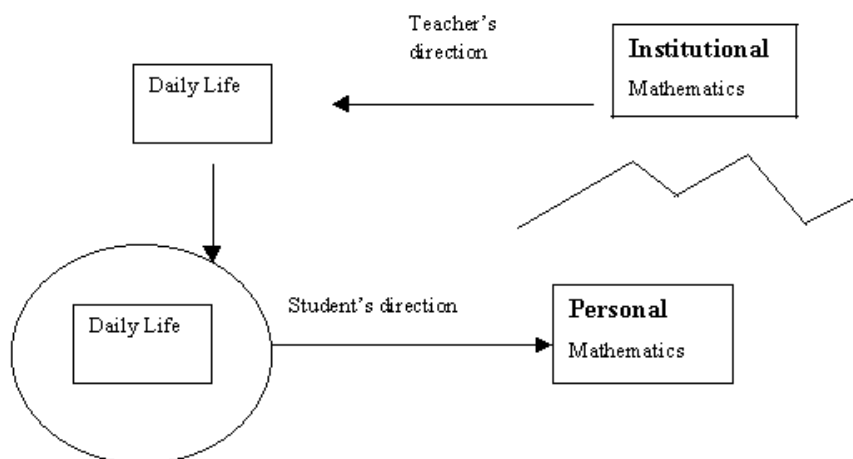

BIBLIOGRAPHY

- Bolite Frant, J. et al. (2004). Reclaiming visualization: when seeing does not imply looking. TSG 28, ICME 10, Denmark [<http://www.icme-organisers.dk/tsg28/>]
- Font, V. (2000). *Procediments per obtenir expressions simbòliques a partir de gràfiques. Aplicacions a les derivades*. Tesis doctoral no publicada. Universitat de Barcelona.
- Font, V. & Acevedo, J. I. (2003). Fenómenos relacionados con el uso de metáforas en el discurso del profesor. El caso de las gráficas de funciones. *Enseñanza de las Ciencias*, 21, 3, 405-418.
- Godino, J. D., Contreras, A. & Font, V. (2004). *Análisis de procesos de instrucción basado en el enfoque ontológico-semiótico de la cognición matemática*. XX Jornadas del SI-IDM. Madrid 2004.
- Johnson, M. (1987). *The body in the mind: The bodily basis of meaning, imagination, and reason*. Chicago: University of Chicago Press.
- Lakoff, G. & Núñez, R. (2000). *Where mathematics comes from: How the embodied mind brings mathematics into being*. New York: Basic Books.
- Leino, A.L. & Drakenberg, M. (1993). *Metaphor: An educational perspective*. Research Bulletin 84, Department of Education, University of Helsinki.
- Núñez, R. (2000). Mathematical idea analysis: What embodied cognitive science can say about the human nature of mathematics, en Nakaora T. y Koyama M. (eds.). *Proceedings of PME24* (vol.1, pp. 3-22). Hiroshima: Hiroshima University.
- Presmeg, N. C. (1992). Prototypes, metaphors, metonymies, and imaginative rationality in high school mathematics. *Educational Studies in Mathematics*, 23 (6), 595-610.
- Presmeg, N. C. (1997a). Reasoning with metaphors and metonymies in mathematics learning. In L. D. English (Ed.), *Mathematical reasoning: Analogies, metaphors, and images* (pp. 267-279). Mahwah, New Jersey: Lawrence Erlbaum Associates.
- Sfard, A. (1994). Reification as the birth of metaphor. *For the Learning of Mathematics*, 14(1), 44-54.
- Sfard, A. (1997). Commentary: On metaphorical roots of conceptual growth. In L. D. English (Ed.), *Mathematical reasoning: Analogies, metaphors, and images* (pp. 339-371). Mahwah, New Jersey: Lawrence Erlbaum Associates.

METAPHORS AND GESTURES IN FRACTION TALK

Laurie D. Edwards, *St. Mary's College of California, USA*

Abstract: *Interviews about fraction with prospective elementary school teachers were analyzed in terms of the gestures and the unconscious metaphors that underlie their conceptions of fractions. The gestures were categorized using a modification of a scheme developed by linguist David McNeill, and also in terms of the specific mathematical context surrounding the students' statements. Distinctive types of gestures were associated with these different contexts, reflecting the students' actions while learning about, calculating with, and solving problems involving fractions.*

Keywords : *metaphor, gesture, fractions, conceptual mapping.*

The theory of embodied cognition holds that thought and ideas are not abstract, transcendent entities, which contrast with the concrete physical experience, but rather that human cognition has developed within the constraints and capabilities that our biology brings to coping with the social and the physical world (Varela, Thompson & Rosch, 1991). Within this theory, the senses, linked to motor activity, are an essential aspect of cognition. As summarized by Varela, "Embodied entails the following: (1) cognition dependent upon the kinds of experience that come from having a body with sensorimotor capacities; and (2) individual sensorimotor capacities that are themselves embedded in a more encompassing biological and cultural context...[S]ensory and motor processes, perception and action, are fundamentally inseparable in lived cognition, and not merely contingently linked as input/output pairs" (Varela, 1999, p. 12). This theory has philosophical and practical implications for mathematics education, because, traditionally, mathematics has been seen as the paradigm of abstract, disembodied reasoning, universally true and not contingent on the physical world. However, recent work in cognitive science has analyzed ways in which mathematical ideas are embodied (Lakoff & Núñez, 2000). Utilizing cognitive mechanisms such as unconscious metaphors, conceptual blends, and image schemas, human beings have constructed mathematical ideas, building on certain primitive "arithmetic" capabilities shared with other members of the animal kingdom (ibid.).

Recently, research into the relationship between physical gesture and language has added a new dimension to the embodied cognition paradigm. According to work in this area, human gestures form an integral part of language, thought and communication. Indeed, there is one school of thought that holds that gesture preceded and scaffolded speech in human evolution, and evidence from neuroscience indicates that the same areas of the brain are involved in the expressive use of gesture and oral language (Corballis, 1999). Recent research within psychology and mathematics education has looked at the role of gesture and embodiment in counting

(Alibali & diRusso, 1999), arithmetic problem solving (Goldin-Meadow, *), algebra and graphing (Nemirovsky, Tierney, & Wright, 1998; Reynolds & Reeve, 2002; Robutti & Arzarello, 2003), and differential equations (Rasmussen, *). Results from this research suggest that, in learning situations, gestures and speech can convey different kinds of information, and that a “mismatch” between gesture and speech can indicate a readiness to learn a new concept or procedure on the part of the student (Goldin-Meadow, *ibid.*), or a foreshadowing of a new concept on the part of the teacher (Rasmussen, *). In addition, gestures can “condense” features of the real world and support the construction of understanding within both traditional and technology-based mathematical representations (Nemirovsky, Tierney & Wright, 1998; Robutti & Arzarello, 2003).

The goal of the research described in this paper was to investigate the kinds of gestures found in students’ discourse about fractions, and to analyze both gesture and talk in order to describe the unconscious metaphors that give rise to these expressions. Fractions are a difficult topic for many children, and also for some pre-service teachers. As a starting point, the research aimed to collect a corpus of speech and gestures related to fractions, within an interview setting. The analysis of the metaphors and gestures found in this setting could then be used in further research into how fractions are learned and how better to teach them.

Methodology

The participants in the research were twelve female prospective elementary school teachers, approximately 20 years of age, enrolled in a required undergraduate mathematics course at a small liberal arts college. The students were interviewed in pairs by the author, in videotaped sessions lasting about 30 minutes. The students were asked the following questions:

How were you first introduced to the idea of fractions?

Do you remember anything that was particularly difficult about learning fractions? What about adding, subtracting, multiplying or dividing fractions?

Have you ever used fractions in everyday life, or in other classes?

How would you introduce fractions to children?

How would you define a fraction to children?

They also worked together to solve five problems involving comparing, adding, subtracting, multiplying, and dividing fractions.

Data Analysis

The data analyzed in this report were taken from a total of three hours of interviews, during which time total of 86 gestures were displayed by the twelve students. The gestures were initially analyzed utilizing a classification scheme established by a linguist, David McNeill (1992). This scheme, which was developed utilizing a set of narratives (descriptive stories), did not fully distinguish the kinds of gestures

displayed by the students when they talked about a mathematical topic. Thus, the classification scheme was modified, and used to categorize all the gestures. A summary of the results of this classification will be presented here; for a full analysis, see Edwards (2002).

Iconics

The gestures displayed by the students fell into three of McNeill's original categories: iconics, metaphorics, and deictics. Iconics are gestures that resemble their referent in the speech. An example from the fraction data is shown in Figure 1, where a student is talking about the physical materials (manipulatives) used when she first learned about fractions (the underlining indicates where the stroke, or most fully-formed, part of the gesture fell within the speech).



Figure 1: “I think we did, like, just a stick or a rod...”

The student's hands are placed as if they were holding a long, narrow object, like the “stick” or “rod” referred to in her speech.

There was a second type of gesture displayed by the students, in this mathematical context, that referred to entities that were not entirely concrete, in the sense of being physical objects that could be touched, but which had certain concrete characteristics, which were reflected in the students' gesture. These were specific mathematical procedures, algorithms, and operations, for example, the algorithm for adding fractions. When students discussed such algorithms, they often created gestures in the air (or on the surface of the table) that reproduced, either in whole or in part, the way that such procedures would be written out on paper. Similarly, in talking about a fraction, students might indicate its “parts” (numerator or denominator) by pointing to an imaginary written fraction, or by “covering” the denominator with a hand.

McNeill's typology included only one category for iconics, which, in his corpus, always referred to concrete, physical objects, rather than to written inscriptions for generalized procedures like mathematical algorithms. In order to

create a more accurate typology for gestures in a mathematical setting, I divided McNeill's category of "iconic" into two sub-types: "iconic-physical" and "iconic-symbolic." Figure 1 would be an example of an iconic-physical gesture, and Figure 2, below, shows an iconic-symbolic (the student is discussing how she learned the algorithm for adding two fractions, working vertically).



Figure 2: "I remember learning that you put one under the other..."

Metaphorics

The second type of gesture found in the data were metaphorics. Metaphorics, according to McNeill, are gestures where "the pictorial content presents an abstract idea rather than a concrete object or event" (McNeill, 1992, p.14). Metaphorics were found referring to a great variety of mathematical abstractions, including comparisons of numbers, equality or similarity, generalized actions ("dividing it up," "reducing it," "doing it themselves"), and generalized mathematical entities like statistics, ratios, and formulas. The gestures associated with ideas of "more" and "less" showed an interesting contrast. There were two cases in which students talked about something more or additional, and in both cases, the gesture consisted of a single tap or touch of the table, followed by another tap or touch to the right of the first one. Figure 3 illustrates the starting position of one of these "more" gestures, with arrow indicating that the gesture concluded with a tap to the right. The context is that the student is discussing what happens when the numerator of a fraction is larger than the denominator, resulting in a mixed number ("one and" the fractional part).

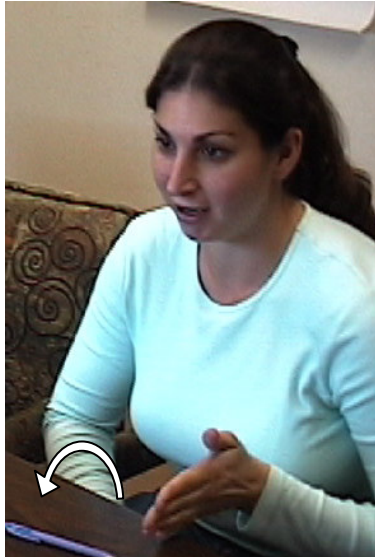

Figure 3: “If it was more than what the bottom was then it would become, like, one and...”

By contrast, the single gesture that referred explicitly to “less” consisted of waving two fingers toward the student’s left, as illustrated in Figure 4.



Figure 4: “We’re each getting less”

Although the pattern of gesturing to the right to indicate “more” and to the left to indicate “less” is at this point a hypothesis that would need to be confirmed with more cases, it is plausible that this contrast is being represented, metaphorically, by gestures that move or point in opposite directions. Furthermore, the choice of directions is probably not arbitrary, but is instead related to metaphors involved in the basic construction of the idea of number.

According to Lakoff and Núñez (2000), there are four basic, or grounding, metaphors for building an understanding of number and arithmetic. Grounding metaphors are those that “directly link a domain of sensory-motor experience to a

mathematical domain” (p.102). One of the conceptual metaphors for arithmetic is moving along a path. In this metaphor, the concrete, physical experience of being at a particular location on a path, and of moving toward or away from a specified point, are used as the source domain for understanding numbers and arithmetic. Under the metaphorical mapping, locations on the path map to numbers, and moving farther away from the beginning of the path (zero) means the numbers are getting larger, while moving in the opposite direction means that numbers are getting smaller. This conceptual metaphor is similar to the more specific metaphor, Numbers-Are-Points-On-A-Line, where the path is specified to be a straight line. The Numbers-Are-Points-On-A-Line mapping is used within the Number Line conceptual blend, which identifies each point on a line with a number, and each number with a point on a line (p. 48). All of these physically-grounded ideas are used in the conventional inscribed representation of the number line, familiar to most primary school children. This “concrete” representation of the number line has certain conventional features that are not specified within the conceptual metaphors or blend. First, the number line is oriented horizontally, and also, the numbers get larger as you move toward the right, and smaller to the left. Although this orientation is not required by the conceptual metaphors or blend, it does provide a possible source for the directions used by the students in the gestures associated with ideas of “more” and “less.”

As a final example of a metaphorical gesture, Figure 5 shows a gesture associated with the concept “same as.”



Figure 5: “and this can still be the same as...”

The student’s hands both have the same “grasping” shape, but she alternates raising one then the other several times. This gesture is similar to two other cases, in which the phrases “just like” and “really match” are associated with alternating up and down gestures of hand-shapes that are similar to each other. This is a concise, yet metaphorical, way of highlighting the “sameness” of two things, since the “things”

being compared (the hands) resemble each other, but do not look like their referents, which might be fractions, other kinds of numbers or any other kind of thing.

Deictics

The final type of gesture found in the corpus of student gestures were deictics. A deictic is a “pointing movement [that] selects a part of the gesture space” (McNeill, 1992, p. 80). Sometimes deictic gestures point to actual objects near the speakers, or to directions in the real world (north, south, front, back, etc.). However, deictic gestures can also indicate imaginary objects, people, or elements of a “space” that has already been constructed through previous gestures and speech. Figure 6 shows an example of a deictic gesture, which is actually the gesture immediately following the one shown in Figure 5. Both of these gestures occurred while the student was describing an initial confusion she had about equivalent fractions. What the student said was, “the whole concept of how you can, it can split and split, and this can still be the same as this.” This phrase was associated with three gestures. The first was an iconic-physical “chopping” motion, corresponding to the phrase “split and split.” The second was the “same as” gesture shown in Figure 5. And, finally, as shown in Figure 6, the second “this” in the sentence was accompanied by a “placing” gesture toward the right, indicating the location, in gesture space, of one of the two equivalent objects.



Figure 6: “this”

Grounding metaphors and fractions

The four grounding metaphors for arithmetic are object collection, object construction, measuring stick, and motion along a path (Lakoff & Núñez, 2000). Both the words and the gestures utilized by the students when talking about fractions can provide evidence about which unconscious metaphor underlies their understanding of

this concept. When the students were asked to give a definition of fraction, only two utilized gestures. The gestures used by these two students are described in Table 1 (abbreviations for the gesture descriptions are: RH, LH, BH= Right hand, Left hand, Both hands; C-, L- and S-shapes=ASL hand shapes).

| Who | Speech | Gesture Description | Type |
|-----|---|---|------|
| KG | But it's only <u>a piece of</u> - | LH, L-shape, cutting motion, palm to face | IP |
| KG | a <u>piece of</u> the wh- | LH, open L, parallel to table | M |
| KG | a piece of <u>whatever we're dealing that's whole</u> | BH, symmetric open L-shapes, thumbs facing body | M |
| KG | it's just <u>a portion of</u> | LH toward body, slightly curled S-shape bounced toward body | M |
| AT | a <u>portion</u> of a pie | slide LH fingers along edge of table | M |

Table 1: Gestures associated with definitions of fractions

The definitions given by students who did not use gestures were quite similar, and included the following:

I would probably put like a part of a whole.

A part to a whole number

A fraction is something that breaks up whole numbers

You're just taking something out of the whole

Both the cutting and slicing gestures, as well as the verbal definitions referring to “parts”, “breaking up” and “taking something” out of wholes indicate that the students are utilizing an object construction metaphor for understanding fractions. Only if whole numbers are constructed of parts can those parts constitute another kind of number, a fraction. Within the “Arithmetic is Object Construction” metaphor, numbers are seen as objects, with the smallest whole object corresponding to the number one (the unit). A simple or unit fraction is understood as being “a part of a unit object (made by splitting a unit into n parts)” and a complex fraction (m/n) as “an object made by fitting together m parts of size $1/n$ ” (Lakoff & Núñez, 2000, p. 67). It should be noted none of the students’ comment or gestures indicated an understanding of fractions in terms of object collections (although it is possible to use fractions to describe a subset of a larger set of objects) or portions of a measuring stick or of a motion along a path. Thus, based on the data collected from these students, the source

domain underlying their ideas about fractions is the idea of a number as an object constructed out of parts.

Discussion

The purpose of the research reported here was to investigate the ways that undergraduate prospective elementary school teachers talked and gestured about fractions, a topic that is often problematic for children (and, sometimes, their teachers). It was hoped that the students' spontaneous, unconscious gestures as well as their speech could help serve as a window into students' understanding of this topic. The gestures displayed by the students fell into four categories: iconic-physical, iconic-symbolic, metaphoric, and deictic. Furthermore, both the students' gestures and their words indicated that their thinking about fractions was based on the conceptual metaphor that considers numbers to be constructed objects. Student gestures related to "more" and "less" seemed to be related to the conceptual blend that identifies numbers as points on the line, and to conventional features of the inscribed number line. Future research will continue to explore gestures related to fractions as well as other mathematical topics, and will undertake a deeper analysis of metaphorical gestures in situations involving mathematical talk, including learning and teaching settings.

References

- Alibali, M. & diRusso, A. 1999. The function of gesture in learning to count: More than keeping track. *Cognitive Development*, 14. 37-56.
- Corballis, M. 1999. The gestural origins of language. *American Scientist*, 87. 138-145.
- Edwards, L. 2002. A natural history of mathematical gesture. Research report presented at "Mathematics and Gesture" Symposium, American Educational Research Association Annual Meeting, Chicago.
- Lakoff, G. & Núñez, R. 2000. *Where mathematics comes from: How the embodied mind brings mathematics into being*. New York: Basic Books.
- Goldin-Meadow, S. 2003. *Hearing gesture: How our hands help us think*. Cambridge, MA: Belknap.
- McNeill, D. 1992. *Hand and mind: What gestures reveal about thought*. Chicago: Chicago University Press.
- McNeill, D. (ed.) 2000. *Language and gesture*. NY: Cambridge University Press.
- Nemirovsky, R., Tierney, C., & Wright, T. (1998). Body Motion and Graphing. *Cognition and Instruction*, 16(2), 119-172.
- Rasmussen, C., Stephan, M. & Whitehead, K. 2003. Classroom mathematical practices and gesturing. Research report presented at "Mathematics and Gesture" Symposium, American Educational Research Association Annual Meeting, Chicago.

Working Group 1

- Reynolds, F. & Reeve, R. 2002. Gesture in collaborative mathematics problem-solving. *Journal of Mathematical Behavior*, 20. 447-460.
- Varela, F. J. 1999. *Ethical know-how: Action, wisdom, and cognition*. Stanford, CA: Stanford University Press.
- Varela, F., Thompson, E. & Rosch, E. 1991. *The embodied mind: Cognitive science and human experience*. Cambridge, MA: MIT Press.

A REVIEW OF SOME RECENT STUDIES ON THE ROLE OF REPRESENTATIONS IN MATHEMATICS EDUCATION IN CYPRUS AND GREECE

Athanasios Gagatsis, *University of Cyprus, Cyprus*

Iliada Elia, *University of Cyprus, Cyprus*

Abstract: *The findings of recent studies are combined and discussed to investigate the effect of different modes of representations on the understanding of mathematical concepts and mathematical problem solving (MPS). The samples of the studies consisted of students of primary and secondary schools in Cyprus and Greece. Despite the variation of the studies on the mathematical content they examined and the research methods they employed, some common remarks have occurred. Compartmentalization (lack of competence in the conversion between different kinds of representations) was a general phenomenon that was observed in students' behavior. Furthermore, the studies' findings concur with the view that the effect of a representation on mathematics learning depends on the context in which it is used.*

Keywords: *representation, compartmentalization, conversion, number line, function, absolute value, problem solving, implicative analysis, similarity diagram*

INTRODUCTION

Last decades a great attention has been given on the concept of representation and its role in the learning of mathematics. A basic reason for this emphasis is that representations are considered “integrated” with mathematics (Kaput, 1987). In certain cases, representations are so closely connected with a mathematical concept, such as a graph with a function, that it is difficult for the concept to be understood and acquired without the use of the particular representation. Each representation, however, cannot describe thoroughly a mathematical concept, since it provides information just to a part of its aspects (Gagatsis & Shiakalli, 2004). Hence, three presuppositions for the mastery of a concept in mathematics are the following: First, the ability to identify the concept in multiple systems of representation; second, the ability to handle flexibly the concept within the particular systems of representation; and third, the ability to “translate” the concept from one system of representation to another (Lesh, Post & Behr, 1987).

Students experience a wide range of representations from their early childhood years. A main reason for this is that most mathematics textbooks today make use of a variety of representations more extensively than ever before, in order to promote understanding. However, a reasonable question that arises is which the actual role of the use of representations is in mathematics learning. A considerable number of recent research studies in the area of mathematics education in Cyprus and Greece

investigated this question from different perspectives. In an attempt to explore more systematically and determine the nature and the contribution of different modes of representations (i.e., pictures, number line, verbal and symbolic representations) on mathematics learning, the present paper reviews and integrates these strands of research, which examine the effect of various representations on the understanding of mathematical concepts and MPS, in primary and secondary education, by presenting and discussing their main findings. Specifically, the studies reported in this paper have examined the role of representations in the following processes or strands of mathematical content: addition and subtraction and solving of one-step routine problems in the context of primary education; functions, ordering of real numbers and absolute value in the context of secondary education. The present review aims at identifying the difficulties that arise in the conversion from one mode of representation of a mathematical concept to another and examining the phenomenon of compartmentalization which may affect in a negative way mathematics learning. We consider that compartmentalization appears when students deal inconsistently or incoherently with relative tasks that differ in a certain feature, i.e., mode of representation. Findings of the studies included in this paper will clarify further the particular phenomenon in students' behavior.

REPRESENTATIONS IN THE LEARNING OF MATHEMATICS IN PRIMARY SCHOOL

The use of number line in the addition and subtraction of natural numbers

Gagatsis, Shiakalli and Panaoura (2003) investigated the use of number line in primary school, as a geometrical model for the understanding of addition and subtraction of natural numbers by 7-8-year old students. For this study's needs four tests (A, B, C and D) including twenty-eight paper and pencil tasks were constructed and administered to 106 students. In test A and test B students were asked to complete 8 mathematical sentences of addition or subtraction, e.g., $8+6=\checkmark$, $17-8=\checkmark$. Students were not allowed to use number line diagrams to complete the tasks of test A, while they had the opportunity to use number line diagrams to complete the tasks of test B. In test C students were expected to complete number line models of addition or subtraction in order to find the results of 8 mathematical facts. Finally, in test D students were expected to write the addition or subtraction sentence to represent the number line model of addition or subtraction.

Students exhibited high success rates in test A (from 97.2% in task A1 to 63.2% in task A8), and test B (from 91.5% in task B1 to 74.5% in task B8). In tests C and D significantly lower scores were observed (from 68.9% in task C1 to 47.2% in task C8, and from 67% in task D1 to 54.7% in D4, respectively). A statistical computer software, namely CHIC, (Bodin, Coutourier & Gras, 2000) was used for the processing of the data. It provided a similarity diagram (Lerman, 1981) that allowed for the grouping of the tasks based on the homogeneity by which they were handled by the students. This diagram (Figure 1) revealed the distinction of the tasks according to the use of the number line that was required. In particular, students' responses to the tasks, where the use of number line was essential (test C and D),

established a cluster of variables with strong similarity relations (Cluster 3). Furthermore, most of students' responses to the tasks, where there was not a number line (test A), formed a separate similarity cluster (Cluster 2). Students' responses to the tasks, where they had the opportunity to use the number line (test B), related directly to each other and were also linked to a part of the responses to the tasks without number line, thus forming another cluster (Cluster 1).

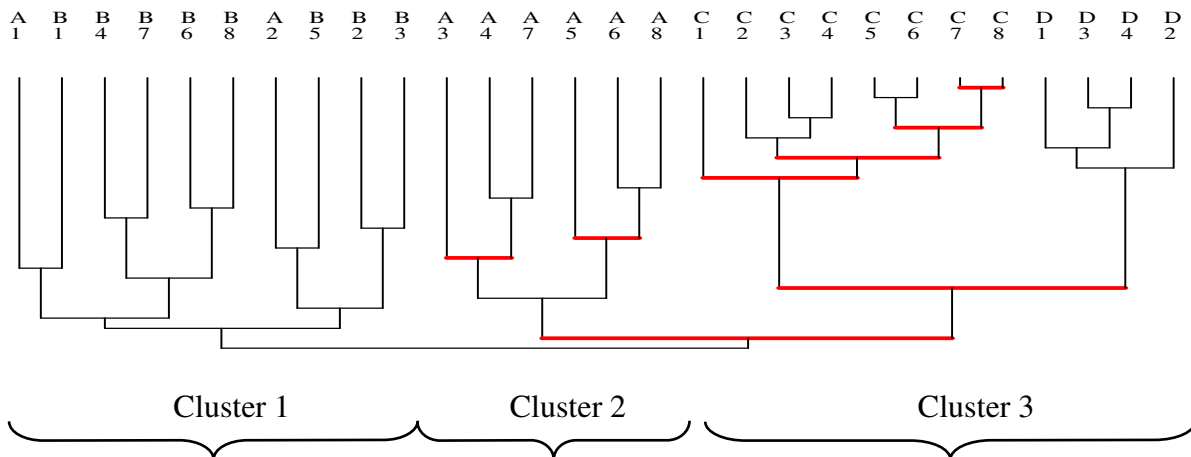

Figure 1: Similarity diagram of students' responses to the tasks of the four tests

Note: The similarities in bold color are important at level of significance 99%.

The above findings indicated the existence of compartmentalization in students' behavior, since they seemed to deal with the tasks with number line in a distinct and inconsistent way relative to the tasks without number line. For example, students who were able to tackle an operation in a symbolic form successfully were not necessarily in a position to represent this operation on the number line correctly. The phenomenon of compartmentalization reveals a cognitive difficulty that arises from the need to accomplish flexible and competent conversion back and forth between different kinds of mathematical representations (Duval, 2002). In the particular study, this difficulty arises from the double nature of number line in the teaching of mathematics. In fact, number line constitutes a geometrical model, which involves a continuous interchange between a geometrical and an arithmetic representation. Based on the geometric dimension, the numbers depicted in the line correspond to vectors and the set of the discrete points of the line. According to the arithmetic dimension, points on the line can be numbered in a way that measuring the distance between the points may represent the difference between the corresponding numbers. The simultaneous presence of these two conceptualizations may limit the effectiveness of number line and thus hinder the performance of students in arithmetical tasks (Gagatsis, Shiakalli & Panaoura, 2003).

Visual representations in MPS

Within mathematics education in Cyprus, concerns have been raised on the role of visual representations on MPS. In particular, a number of recent studies, carried out in Cyprus, have investigated the effects of different types of pictorial representations

on primary students' MPS performance. One of the most significant commonality that characterizes these studies is the categorization of pictures they used in order to examine the role of each type of pictures in students' performance, in MPS. On the basis of Carney and Levin's (2002) proposed functions that pictures serve in text processing, the studies presented in this section suggest four functions of pictures in MPS: (a) decorative, (b) representational, (c) organizational, and (d) informational. Decorative pictures do not give any actual information concerning the solution of the problem. Representational pictures represent the whole or a part of the content of the problem, while organizational pictures provide directions for drawing or written work that support the solution procedure. Finally, informational pictures provide information that is essential for the solution of the problem.

In one of these research studies, Theodoulou, Gagatsis and Theodoulou (2004) investigated which categories of pictures (decorative, representational, organizational and informational) had a positive effect on second grade students' performance in the solution of standard problems. Two tests were administered to the participants. The first test consisted of verbal problems and the second test involved the same problems accompanied by pictures. A problem accompanied by an informational picture that was included in the second test is given in Figure 2.

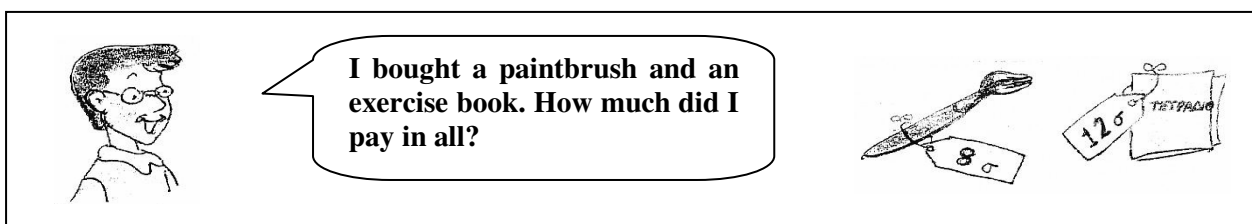

Figure 2: A problem with an informational picture in the second test on MPS (Theodoulou et al., 2004)

Results showed that decorative pictures did not have any effect on children's MPS performance. They may have helped to make the text more attractive, but they were unlikely to enhance desired outcomes related to understanding or applying the problem content. Representational pictures had a significant positive role in some cases, according to the mathematical operations needed to solve the problem. In particular, it was found that the more complex the structure of the problem, the more likely it was that representational pictures were helpful. On the other hand, organizational pictures had a clearly significant positive effect on students' achievement. This finding suggests that pictures having this particular function helped students understand the structure of the problem and organize the data in order to reach a solution for the problem. As for informational pictures, despite their essential informational role, they did not have a positive effect on students' MPS performance relative to their performance when the information in the picture was included in the problem text. The similarity diagram (Figure 3) shows how tasks are grouped according to the similarity of the ways in which they were solved.

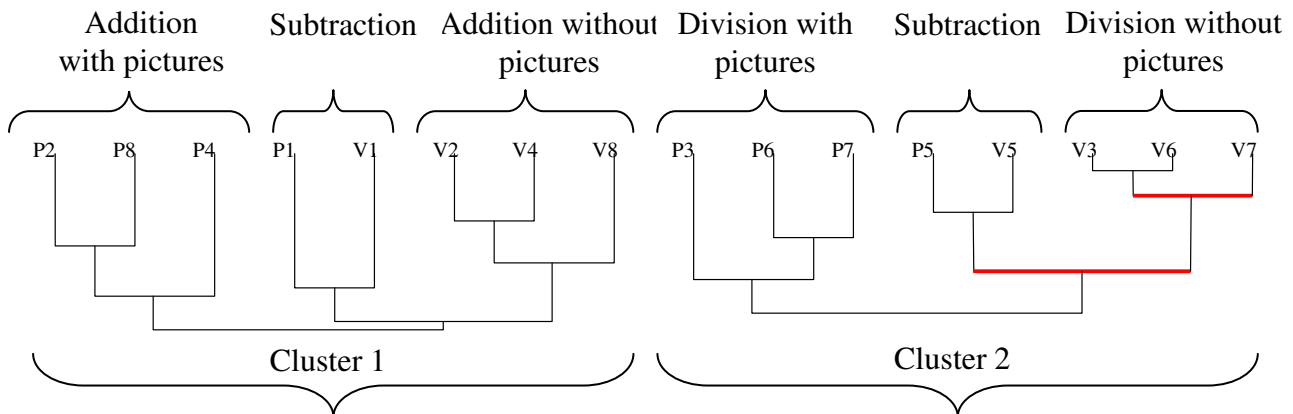

Figure 3: Similarity diagram of students' responses to the problems of addition, subtraction, multiplication and division with and without pictures

Two clusters are identified in Figure 3. The first cluster consists of students' responses in the addition problems and in a part of the subtraction problems. The second cluster involves students' responses in the division problems and in another part of the subtraction problems. The formation of these clusters indicates that students deal with addition problems in a different manner from division problems, indicating the impact of the mathematical operation involved in the problems on students' performance. This effect is enhanced by the formation of a separate group of two variables that represent students' responses in subtraction problems within each cluster. It is obvious that the inclusion of a picture in the problem context also has an influence on students' responses. This remark is supported by the formation of a group involving students' responses in tasks of addition or division accompanied by pictures and a distinct group of students' responses in tasks of addition or division problems without pictures, respectively, in each cluster. Hence, the phenomenon of compartmentalization appears in students' behavior when solving routine problems in different representational forms, i.e., verbal and pictorial. Moreover, it can be inferred that the kind of mathematical operation needed in order to solve the problem (e.g., addition, division) contributes more to the formation of similarity groups of students' responses to the tasks, than the mode of representation of the problem.

REPRESENTATIONS IN THE LEARNING OF MATHEMATICS IN SECONDARY SCHOOL

Representations and the concept of function

The concept of function is of fundamental importance in the learning of mathematics and has been a major focus of attention for the mathematics education research community (e.g., Dubinsky & Harel, 1992; Gagatsis & Shiakalli, 2004). To determine whether a conversion back and forth between different kinds of mathematical representations of function is accomplished by students of grade 9 (14 years old), Gagatsis, Elia and Andreou (2003) conducted a research examining a possible compartmentalization of the modes of representation of functions (i.e., graphic, symbolic, verbal). In particular, two tests were administered to the 183 participants of the study. The first test (A) consisted of 6 tasks in which students were

given the graphical representation of an algebraic relation and were asked to “translate” it to its verbal and algebraic form, respectively. The second test (B) consisted of 6 tasks (involving the same algebraic relations) in which students were asked to “translate” a relation from its verbal representation to its graphical and algebraic mode, respectively. For each type of conversion, the following types of algebraic relations were examined: $y < 0$, $xy > 0$, $y > x$, $y = -x$, $y = 3/2$, $y = x - 2$.

The application of Gras’s statistical implicative analysis to the collected data by using CHIC produced the implicative diagram in Figure 4.

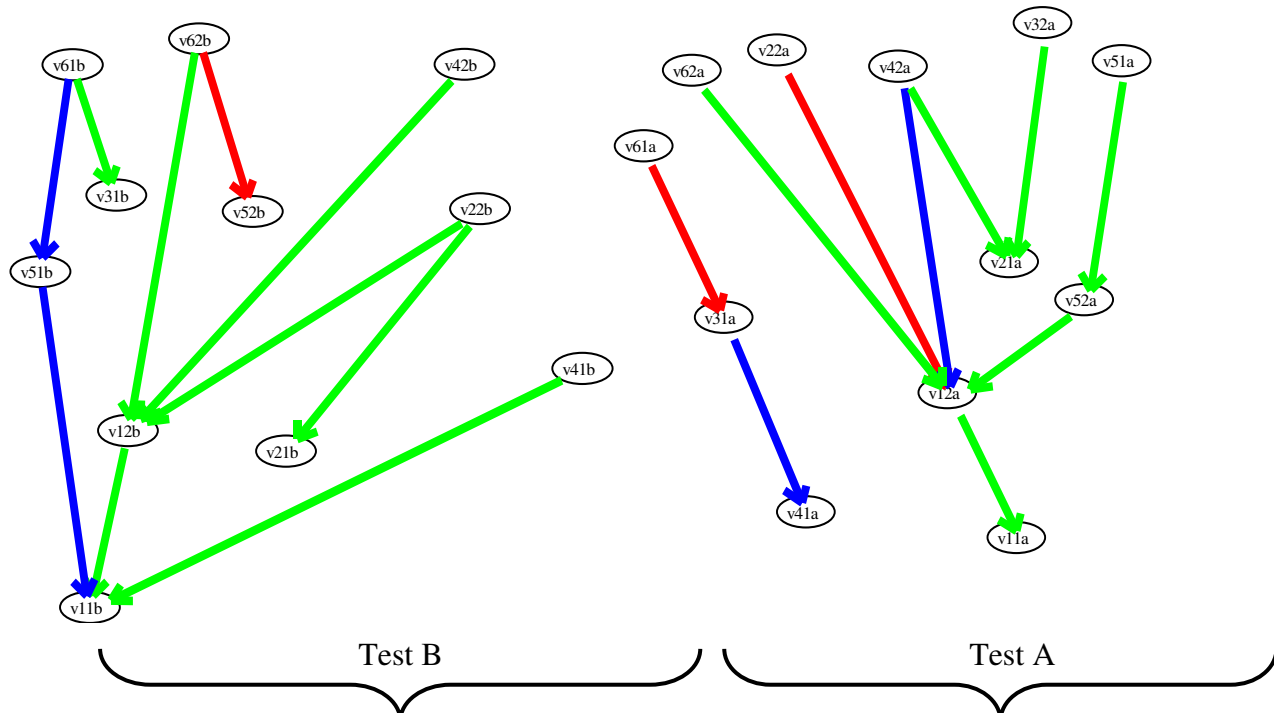

Figure 4: *Implicative diagram of students’ responses to the two tests for function*

The implicative diagram contains implicative relations, which indicate whether success to a specific task implies success to another task related to the former one. Figure 4 shows that there was a compartmentalization between students’ responses to the tasks of the first test and the tasks of the second test, although they involved the same algebraic relations. This finding reveals that different types of conversions among representations of the same mathematical content were approached in a completely distinct way. For example, students who accomplished the conversion from a graphical representation of an algebraic relation to its verbal representation were not automatically in a position to translate successfully the same algebraic relation from its verbal representation to its graphical form and vice versa. This behavior indicated that students did not construct the whole meaning of the concept of function and did not grasp the whole range of its applications. As Even (1998) supports, the ability to identify and represent the same concept in different representations, and flexibility in moving from one representation to another allow students to see rich relationships, and develop deeper understanding of the concept. Similar findings emerged from a replication of this study to older students (Grade 11),

even though success rates to the tasks were higher in this case than in the case of ninth graders.

The axis of real numbers in the understanding of the ordering of numbers and absolute value

Pantsidis, Zoulinaki, Spyrou, Gagatsis and Elia (2004) investigated the difficulties that arise in the handling of a complex mathematical construction, i.e., the axis of real numbers. The sample of the study consisted of 295 students of Grade 10 in Greece, who were familiar with the use of the axis of real numbers from previous years. The test that was administered to the participants included tasks such as placing of numbers on the axis of real numbers (Figure 5, Task 7) and representation of solutions of inequalities with or without absolute value on the axis of real numbers (Task 3). It also consisted of tasks which combined the ordering, the absolute value and the projection of a point on the axis (Task 8). Figure 5 presents an extract from the test.

| | | |
|--|---|---|
| 3. Indicate on each of the axes the solution of the corresponding inequality. | | |
| $X-1 < 3$ | $ X -1 < 3$ | $X^2-1 > 3$ |
| <hr style="width: 100%;"/> <p style="text-align: center;">4 -3 -2 -1 0 1 2 3 4</p> | <hr style="width: 100%;"/> <p style="text-align: center;">-4 -3 -2 -1 0 1 2 3 4</p> | <hr style="width: 100%;"/> <p style="text-align: center;">-4 -3 -2 -1 0 1 2 3 4</p> |
| 7. Place number $\sqrt{2}$ on the axis of real numbers, at first approximately and then exactly. | | |
| 8. If point A can be anywhere on the circle then mark the following sentences: (T) for True and (F) for False. | | |
| a) $X=2$ | d) $ X \leq 2$ | |
| b) $X \leq 2$ | e) $ X = 2$ | |
| c) $-2 \leq X \leq 2$ | | |
| | | |
| | | |

Figure 5: An extract from the test on the use of the axis of real numbers

Findings showed that students achieved better results in the ordering and placing of given natural numbers, the solution of simple inequalities and the representation of their solution on the axis. The solution of inequalities including absolute value caused difficulties, which appeared to be greater in the solution of quadratic inequalities. The application of the implicative analysis on the data generated a similarity diagram (Figure 6), which involved two distinct clusters. The first cluster (Cluster 1) consists of tasks involving the algorithmic resolution of inequalities and placement of numbers on the axis of real numbers (Tasks 1-7), while the second cluster (Cluster 2) consists of the geometric tasks that combined the arrangement, absolute value and projection of a point on the axis of real numbers (Task 8).

The structure of the diagram indicates a compartmentalization of the tasks of the test. Students approached in a completely distinct way the tasks which involved the use of the axis of real numbers in a geometrical context, relative to the tasks involving the algorithmic resolution of inequalities and placement of numbers on the axis. It can be

asserted that the use of another geometrical representation connected to the axis of real numbers leded students to a completely different approach. Therefore, possible instructive activities would focus on the unification of the two different groups of tasks.

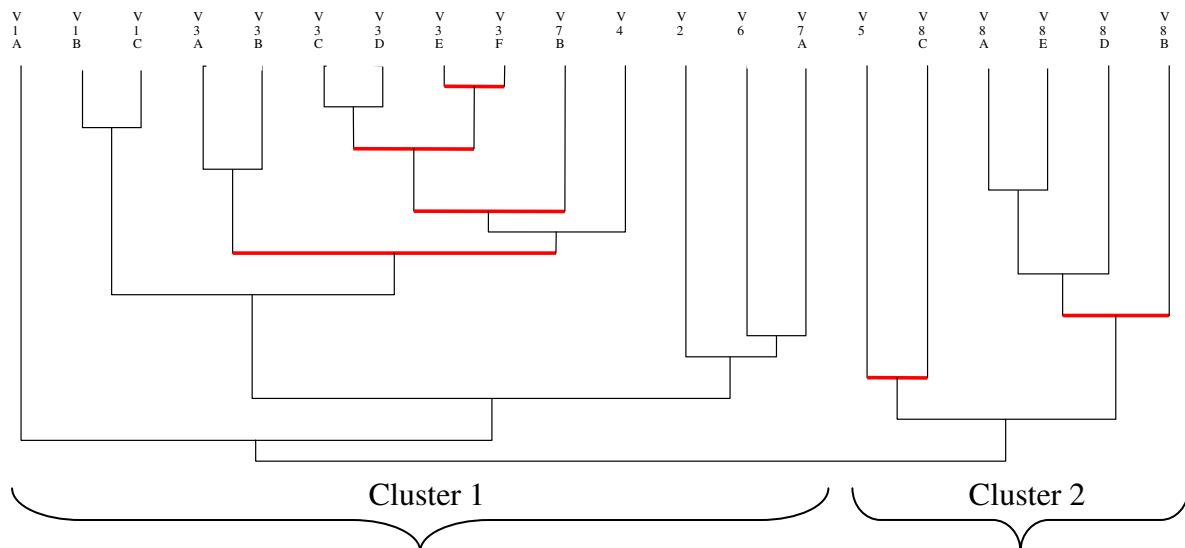

Figure 6: Similarity diagram of the tasks on the use of the axis of real numbers

DISCUSSION

This paper integrates the findings of recent studies to investigate the role of external representations in the learning of mathematical concepts and MPS by students ranging in age from 7 to 16 years old. Even though these studies were conducted in different settings, with various age samples, using diverse research methods, some of their findings are congruent. This consistency promotes the significance, validity and applicability of their findings. Furthermore, this review entailed some considerations as regards the difficulties confronted by students when dealing with different modes of mathematical representations as well as the phenomenon of compartmentalization.

Success in one mode of representation of a concept or in solving a problem does not necessarily imply success in another mode of representation for the same concept or the same problem. Lack of implications or connections among different modes of representations indicates the difficulty in handling two or more representations in mathematical tasks. This incompetence is the main feature of the phenomenon of compartmentalization in representations, which was detected in most of the research studies included in this paper. The differences among students' scores in the various conversions from one representation to another, referring to the same algebraic relation or function or other mathematical concept provides support to the different cognitive demands and distinctive characteristics of different modes of representation. This inconsistent behavior can be also seen as an indication of students' conception that different representations of the same concept are completely distinct and autonomous mathematical objects and not just different ways of expressing the meaning of a particular notion. Compartmentalization is perhaps the only general

phenomenon related to the field of representations, since it appears in the learning process of different mathematical concepts, in different forms of representation, in the behavior of students of different age. Learning, however, can be accomplished through “de-compartmentalization” and coordination of different representations of the same mathematical situation (Duval, 2002). Therefore, the use of multiple representations in mathematics learning, the connection and comparison with each other and the conversion from one mode of representation to another should not be left to chance, but should be taught and learned systematically, so that students develop the skills of representing and handling flexibly mathematical knowledge in various forms.

Based on the findings of the research studies reported in this paper, it can be inferred that the use of representations has a significant, but not always a positive effect in the learning of mathematics, such as the number line in addition and subtraction of natural numbers. Moreover, the effect of a mode of representation in mathematics learning depends on the context it is examined. Thus, general assertions, such as “representations help understanding or the development of mathematical thinking”, do not contribute substantially for the research in mathematics education or mathematics teaching. Systematic and analytical exploration of the effect of specific modes of representations, in specific concepts or procedures, in the behavior of students of specific age, culture etc., are critical for the articulation of verified, substantial and applicable conclusions.

Also, the review of research for this paper indicated that in several cases, researchers use various terms for describing the same mode of representation or even use the same term for referring to different modes of representation. Therefore, a clarification of the different types of representation (such as analogous, diagrammatic, visual, graphical representations) needs to be conducted, in order to accomplish the integration and comparison of various research studies in the field of representations in mathematics education. Similarly, a clarification of the terms conversion, translation, transformation, transition etc., which are widely used in research papers in the same domain is also essential. In a mathematical task one can distinguish treatment from conversion. This distinction is complex and has not been employed in the studies of this paper. Using this distinction could be interesting and beneficial in future research focusing on mathematical representations.

REFERENCES

- Bodin, A., Coutourier, R. and Gras, R.: 2000, *CHIC : Classification Hiérarchique Implicative et Cohésive-Version sous Windows – CHIC 1.2*, Association pour la Recherche en Didactique des Mathématiques Rennes.
- Carney, R. N. and Levin, J. R.: 2002, ‘Pictorial illustrations still improve students’ learning from text’, *Educational Psychology Review* 14(1), 101-120.

- Dubinsky, E. and Harel, G.: 1992, 'The nature of the process conception of function', in E. Dubinsky and G. Harel (eds.), *The Concept of Function. Aspects of Epistemology and Pedagogy*, The Mathematical Association of America, Washington, DC, pp. 85-106.
- Duval, R.: 2002, 'The cognitive analysis of problems of comprehension in the learning of mathematics', *Mediterranean Journal for Research in Mathematics Education* 1(2), 1-16.
- Even, R.: 1998, 'Factors involved in linking representations of functions', *The Journal of Mathematical Behavior* 17(1), 105-121.
- Gagatsis, A., Elia, I. and Andreou, S.: 2003, 'Representations and mathematics learning: Functions and number line', *Euclides* γ 59, 5-34 (in Greek).
- Gagatsis, A. and Shiakalli, M.: 2004, 'Ability to translate from one representation of the concept of function to another and mathematical problem solving', *Educational Psychology* 24(5), 645-657.
- Gagatsis, A., Shiakalli, M. and Panaoura, A.: 2003, 'La droite arithmétique comme modèle géométrique de l'addition et de la soustraction des nombres entiers', *Annales de didactique et de sciences cognitives* 8, 95-112.
- Kaput, J. J.: 1987, 'Representation systems and mathematics', in C. Janvier (ed.), *Problems of Representation in the Teaching and Learning of Mathematics*, Lawrence Erlbaum, Hillsdale, NJ, pp. 19-26.
- Lerman, I.C.: 1981, *Classification et Analyse Ordinale des Données*, Dunod, Paris.
- Lesh, R., Post, T. and Behr, M.: 1987, 'Representations and translations among representations in mathematics learning and problem solving', in C. Janvier (ed.), *Problems of Representation in the Teaching and Learning of Mathematics*, Lawrence Erlbaum, Hillsdale, NJ, pp. 33-40.
- Pantsidis, C., Zoulinaki, F., Spyrou, P., Gagatsis, A. and & Elia, I.: 2004, 'Understanding of the ordering of numbers and the use of absolute value on the axis of real numbers', in A. Gagatsis, F. Spagnolo, Gr. Makrides and V. Farmaki (eds.), *Proceedings of the 4th Mediterranean Conference on Mathematics Education*, Vol. 1, Cyprus Mathematical Society, Palermo, pp. 341-353.
- Theodoulou, R., Gagatsis, A. and Theodoulou, A.: 2004, 'Un' imagine vale piu di mille parole... Ma che tipo di imagine risulta piu efficace nell'attivita di problem solving matematico degli studenti?', *La matematica e la sua didattica* 2, 4-32.

**METAPHORICAL OBJECTS AND ACTIONS
IN THE LEARNING OF GEOMETRY.
THE CASE OF FRENCH PRE-SERVICE PRIMARY TEACHERS**

Françoise Jore, *Université Catholique de l'Ouest (Angers, France)*

& Equipe DIDIREM, Université Paris-7, France

Bernard Parzysz, *I.U.F.M. Orléans-Tours (France)*

& Equipe DIDIREM, Université Paris-7, France

Abstract: *During the first school years, through elementary and junior high school, one major aim of the teaching of geometry is to help the students move from a 'geometry of drawings' (G1) towards a more theoretical geometry (G2). The geometrical drawings, as well as the language associated with them, about actions as well as about objects, are crucial points in this shift, since they move from the status of objects of study (on which physical actions are performed) to the status of physical representations of theoretical elements used in a metaphoric way. In particular, at the beginning of high school this causes a great ambiguousness among students, possibly reinforced by the associated language, which is much the same as the one in use at elementary school. In this paper, we study some features of this problem and propose some elements for further investigation.*

Keywords : *pre-service elementary teachers, geometrical drawings, construction problems, metaphorical actions.*

Following many authors, we consider elementary geometry as a body of knowledge embodied in the 'physical' world [Lakoff & Nuñez 2000], even if it is intended to become, throughout schoolyears, part of a mathematical theory. More precisely, we consider that the geometry which is taught through elementary and secondary schools successively refers to two paradigms, the first one ('spatio-graphical' geometry, or G1) tending to be progressively replaced by the second ('proto-axiomatic' geometry, or G2). A consequence is the existence of quite a period of time during which these two paradigms co-exist and compete with each other, in a more or less visible way. This competition is frequently deceptive, since G2 rests strongly on G1 by using its elements as metaphors, not only for objects (the so-called 'figures') but also for actions (for instance the so-called 'constructions'). More precisely, this paper deals with the following questions : What are constructions within the G1 paradigm? within the G2 paradigm? In what sense do the first ones appear as metaphors for the second ones ? What are the observable effects of the fundamental ambiguousness on students? What can be done to give them a better access to theoretical geometry ? In what follows, we shall try to give some elements for answering these questions, taken from a current research with French pre-service elementary schoolteachers.

1. Theoretical frame

Different geometrical paradigms appear in the course of the long time devoted to the learning of geometry. Two of them are of particular importance at junior high school level:

- the first one, sometimes called ‘spatio-graphical’ geometry ([Laborde & Capponi 1995]) or G1 ([Houdement & Kuzniak 1998], [Parzysz 2002]), is a formalisation of the physical space; in this geometry, the objects (models, drawings on a sheet of paper, or a blackboard, or a computer screen...) have a physical nature; the actions are actually carried out on the objects ; the validations of the results are mostly perceptive and performed with or without the help of specific instruments (comparison, measures);
- the second one, or ‘proto-axiomatic’ geometry ([Parzysz 2002]) can be considered as a geometry partially theorized, the implicit reference of which is a Euclidian axiomatic theory, as for instance those elaborated by Hilbert and Choquet. Its objects (configurations) have a theoretical nature; the actions refer to these theoretical objects and the validations are of a ‘hypothetic-deductive’ type (mathematical proofs).

Very roughly, one could say that G1 is the kind of geometry at work at elementary school, while G2 is the geometry in use at senior high school level. Hence one of the aims of geometry teaching in junior high school is to help the students move from one paradigm to the other, and this, for some reasons that will be discussed below, is not an easy job and may take a lot of time. In fact, the construction of geometrical concepts may require several years, for “*concepts often go through a stage where they are multiple-determined : simultaneously determined by different ‘worlds’, implying different rules, norms, and concepts*” [Van Oers 2002 p. 34]. And, during this time, many junior high school students remain in a kind of geometrical ‘twilight zone’, according to Van Oers’s nice metaphor: “*in [Vygotsky’s] view these transition stages are always characterized by two ‘worlds’ coexisting at one time so that the situation can be described as belonging to both worlds, or to none of them in particular. It is like twilight, where night and day meet each other and it is neither day or night in the full meaning of these worlds.*” [op. cit. pp. 51-52].

In addition to the fact that many junior high school students are in this geometrical ‘twilight zone’, two particular features make it even more difficult to know the difference between G1 and G2 *and*, for the teacher, to ascertain to which paradigm a given student stands ‘closer’.

The first feature is that both G1 and G2 make constant use of geometrical drawings, which are often of the same type (i.e. made with the help of drawing instruments). In the case of G1, a drawing *is* indeed the object on which the work is done; in G2, it is a representation of the theoretical object, but the mere observation

of a drawing does not make it possible to ascertain which paradigm it refers to. It is often the case that, although they are supposed to work on a G2 situation, some students work in fact on a corresponding G1 situation. This has been pointed out by Edwards, among others, in the particular case of geometrical microworlds: “*When [students] look at the graphical window of the microworld, they see a continuous (but normally "invisible") plane that provides a background, on which geometric figures are located. The commands (the geometric transformations) are used to move the geometric figures around on top of this plane. By contrast, for the mathematician, the plane consists of an infinite number of discrete points, and transformations are simply mappings of those points that preserve some properties and change others.*” [Edwards 2002].

The second feature is that in both G1 and G2 the discourse about the geometrical situation in play makes use of many polysemous words, regarding as well the objects in play and the ‘actions’ performed on them (see below). For instance:

- a ‘circle’ may both be a figure drawn with compasses and the set of the points situated at a given distance from a given point;
- ‘to draw a circle’ may as well mean to make a drawing on a sheet of paper as well as be a metaphor indicating that the theoretical object can be defined from the objects previously defined.

[N.B. *We will not use the word ‘figure’, which is currently used in French but suffers from an awkward polysemy : sometimes it means an object of the theory, defined by a wording, and sometimes a physical representation of such a theoretical object (especially a drawing). We shall rather use the phrases ‘theoretical object’ for the first meaning and ‘geometrical drawing’ for the second.*]

These particular features make it generally difficult, just by observing a student’s production, to tell anything about his/her position with respect to G1 and G2. However, in some cases, studying a student’s discourse makes it possible to guess it, for instance when he/she uses perceptive data in a geometrical proof.

Let us now exemplify some difficulties caused by these specific features of elementary geometry with the case of construction problems. In so doing, we shall see, in this case as well as in problem solving tasks, that some clues can provide an insight on the type of geometry in which a given student is working.

2. Constructions within G1 and G2

As said above, the G1 and G2 paradigms are not only defined by the objects in play (physical or theoretical) and the kind of validations accepted (perceptive or hypothetic-deductive), but also by the *actions* performed on the objects. Like the word ‘figure’, the word ‘action’ has various meanings ; for instance Duval [Duval 1994] insists on the possible processings which can be operated on a geometrical drawing (‘figure’), namely mereological, optical and positional changes. In this paper

we shall deal, within plane geometry, with a particular and well-known type of action called ‘construction’; we shall also consider this word as meaning an action, and not the result of the action.

What is a construction in G1 and in G2?

In G1, what is traditionally called ‘construction’ is an actual operation consisting in the making of a geometrical drawing on a sheet of paper, a blackboard or a computer screen, with the help of devices which may be specified or not. In the case of paper-and-pencil environment, rulers, compasses, squares and protractors are the usual instruments used in geometry classes, together with others which are less ‘classical’ (for instance the edges of a ruler, intended to draw parallel lines). In the case of computer environment, the ‘instruments’ are the basic objects which can be drawn by the software (a line passing through two given points, a line perpendicular to another, a circle centred on a given point and passing by another given point, etc.).

In any case, for pedagogical reasons it is possible for the teacher to oblige the students to use only particular instruments:

- in a computer environment, he/she may prevent the use of some tools of the software by hiding them from the students;
- in a paper-and-pencil environment, he/she will forbid the use of instruments other than those which are explicitly specified. For historical reasons (cf. for instance [Parzysz 2001]) the association ruler-and-compasses is the most frequent set of allowed instruments, and it is usually used, even when nothing is said about which instruments are to be used.

In G1, the answer to a construction task is a *drawing* obtained from a given drawing ; it may be accompanied by a description of the sequence of actions applied on the initial drawing in order to get the required final drawing.

In G2, a solution for a construction task consists of a *sequence of assertions* allowing the determination of a theoretical object under some fixed constraints, on the basis of other objects (given objects), i.e. proving its existence and, if requested, indicating how many different objects fulfil the imposed constraints. Depending on the case, these constraints can be of various natures; for instance, they may impose that the only objects to appear in the process should belong to fixed types (e.g. lines and circles), or forbid any measuring (distances, angles...), etc. Usually, the written discourse is accompanied by a drawing representing the final configuration, i.e. the initial configuration and the ‘new’ objects mentioned in the text; in this case, the drawing merely plays an illustrating role.

The associated formulations

For instance, the following construction problem could be posed within G2:

“How can one get the perpendicular bisector of two points, A and B, by using only straight lines and circles?”

But a much more frequent formulation of this problem –in fact the only one used in classes- is:

“Draw the perpendicular bisector of two points A and B, using only ruler and compasses. ” The phrase ‘ruler and compasses’ thus appears as a metaphor for describing the constraints. More generally, the language used to pose a G2 problem is directly borrowed from the language used in G1.

But the constraints (i.e. the wording) are not the only features which are expressed in G2 with a metaphorical language taken from G1; it is the same for the constructions themselves (i.e. the answer). We shall now show it with an example.

Let us go back to the problem given above as an example. Here are two possible formulations for the construction of the perpendicular bisector of A and B in G2:

Formulation 1

- 1- *The circle centred on A and passing by B exists and is well defined;*
- 2- *The circle centred on B and passing by A exists and is well defined;*
- 3- *The intersection of these two circles is constituted of two points, which are to be called I and J;*
- 4- *The line (IJ) is the perpendicular bisector of [AB].*

This list of assertions can be considered as a construction in G2. It may (must) be completed with a justification for each of the four items by definitions and theorems belonging to Euclidian geometry. Obviously, this formulation is not the only one possible, and numerous others would be equally acceptable. Moreover, it is not usual, and the following one looks much more familiar :

Formulation 2

1. *Draw the circle centred on A and going through B ;*
2. *Draw the circle centred on B and going through A ;*
3. *These two circles intersect in two points, I and J ;*
4. *Draw the line (IJ) ; it is the perpendicular bisector of [AB].*

In the present case the language used refers to action, physical gesture, motion. It is used spontaneously because it is the language used for effective constructions in G1. Using the language of action is thus shifting metaphorically the problem from G2 to G1. When an ‘expert’ is working on a geometrical drawing, he/she is aware, at any moment, that this drawing is only a representation of the theoretical object; in a similar way, he/she is also aware that the metaphor can be extended to the actions performed on the objects. But this is far from being the case for most junior high school students (and for pre-service elementary schoolteachers as well); to many of them, these metaphors will not be perceived as such and will in fact become obstacles to the learning of geometry.

For elementary school pupils, geometrical drawings are not metaphors of a theoretical object but the very objects on which they work; in the same way, to them a list of actions as the one listed above (formulation 2) is not a metaphor for theoretical actions, but is a sequence of gestures to be physically performed. Our hypothesis is that, even when the teacher make students work in G2, the constant use of such language, apparently referring to physical actions, may lead some students to become more concerned with the gestures that they perform than with the theoretical objects that they are supposed to deal with, and thus contributes to confine them in G1. This hypothesis is based on our current research with pre-service elementary schoolteachers, among whom we have found frequent clues of a link between the formulations used by a student and the ‘geometry’ in which he/she works ‘spontaneously’. In this short paper we can only give an example of such a link, based on the productions of two pre-service teachers : Jennifer and Audrey.

3. The Jennifer and Audrey cases

The two items dealt with in this section are part of a questionnaire about geometry, taken by more than 700 French pre-service elementary schoolteachers at the very beginning of their training.

Item 1: two points, M and N, are drawn near the centre of a sheet of paper. The first task is to draw the perpendicular bisector of M and N and indicate which properties of the bisector and which drawing instruments have been used to do so. Later, the students are requested to indicate the successive stages of their construction.

The construction task is clearly situated in G1, but the students (though most of them have taken non-scientific curricula) are supposed to be used to working in G2, since they all have passed through high school. In fact, practically all these students have passed a bachelor’s degree, and one could expect that, at such a level, they would spontaneously look at the situation from a G2 viewpoint; but our current study shows that it is far from being the general case.

To answer the last question the students produced quite a variety of texts; here are two of them, of course chosen on purpose.

Audrey

Draw two identical circles centred on N and on M.

Draw the straight line passing by the intersecting points of these circles.

This line is the perpendicular bisector of segment [MN].

Proof : the bisector is the line going through the middle of a segment and which is perpendicular to it. All the points of the bisector are equidistant from the extremities of the segment.

Jennifer

- With compasses:

* Place the point of the compasses on M and take the measure of segment $[MN]$

* Draw an arc of a circle on each side of the segment

* Place the point of the compasses on N and do the same thing

- With ruler:

* Link the two points obtained as intersection points of the two circles.

One can see that Audrey's formulation resembles our own formulation 2, even if she does not give any limitation for the radii of the circles and if her proof is unclear on the essential point of knowing which property of the bisector is used. On the other hand, Jennifer's formulation is embedded in the gestures to be performed, which are described in great detail (e.g. where to put the points of the compasses). She also gives indications to draw arcs of circles rather than circles, i.e. only the 'useful' part of the circles, which possibly reveal a 'technical' point of view.

We could perhaps make a first guess on the basis of these formulations: Jennifer seems to be 'rather on the G1 side', while Audrey would be 'rather on the G2 side'.

The same questionnaire contained another item, for which we shall now have a look at the answers given by Audrey and Jennifer.

Item 2:

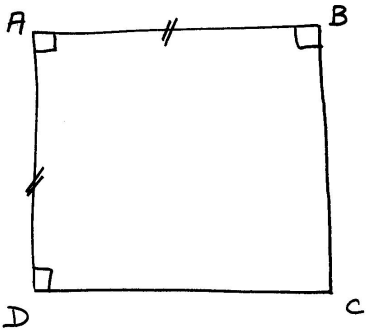
| | |
|---|--|
|  | <p>What can you say about quadrilateral ABCD ? How do you know it ? Explain in detail.</p> |
|---|--|

This task is voluntarily ambiguous:

- if it is understood as belonging to G2, the answer to the first question will be "ABCD is a square", since the geometrical properties coded on the drawing are sufficient to assert it;
- if it appears as being in G1, the answer cannot be the same because, on a perceptive point of view, ABCD does not look like a square.

However, the codes shown on the drawing are known by all the students, and, being used a great deal at high school level (where G2 is the ‘official’ geometry), one could expect that this feature would prompt the students to give an answer in G2.

As a matter of fact, Audrey’s answer says:

It is a square. A quadrilateral which has 2 sides of the same length and 3 consecutive right angles is a square.

But Jennifer’s answer is:

ABCD has 3 right angles. $AD = AB$. We cannot call it a square because C is not a right angle.

From what has been said above, Jennifer’s answer can be seen as ‘rather on the G1 side’, because it rests on the physical properties of the drawing (‘C is not a right angle’) On the contrary, Audrey’s answer is again ‘rather on the G2 side’, because it is based on geometrical properties of the theoretical object represented by the drawing; she clearly considers this drawing as a coded image representing a geometrical configuration. So, this second item confirms the impression given by the first one : even if they work on the same tasks, Audrey and Jennifer do not practice the same kind of geometry.

4. What about textbooks?

The first years of junior high school are a crucial time for enabling the students to shift from G1 towards G2. That is the reason why we have studied the usual textbooks of that level. In this paper we will only consider one example, taken from two first-grade textbooks, and more precisely observe how they deal with the construction of the perpendicular bisector.

Textbook 1¹

Example. In order to draw the perpendicular bisector of a segment [AB] :

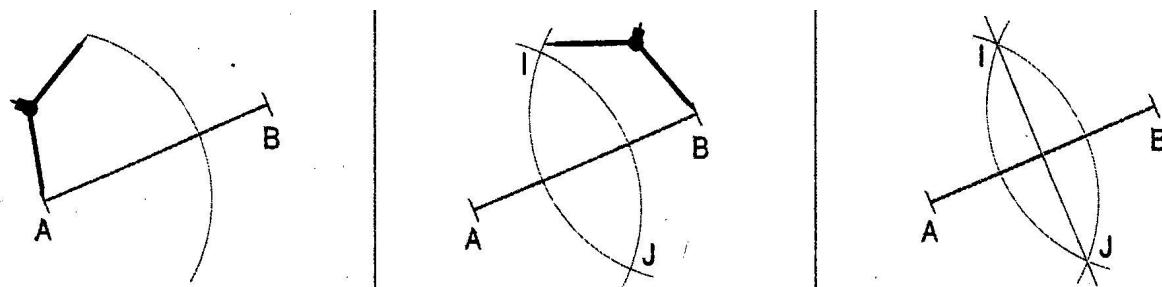

(1) Draw an arc of a circle centred on A, with a radius more than half the length of AB.

(2) Keeping the same radius, draw an arc of a circle centred in B : the two arcs of circle intersect in I and J.

(3) Draw the line (IJ) : it is the perpendicular bisector of [AB].

¹ Collection Triangle. Ed. Hatier 2000, p. 206.

Textbook 2²

EXAMPLE On a non-squared sheet, draw a segment $[AB]$; with a non-graduated ruler and a pair of compasses, construct the perpendicular bisector of this segment.

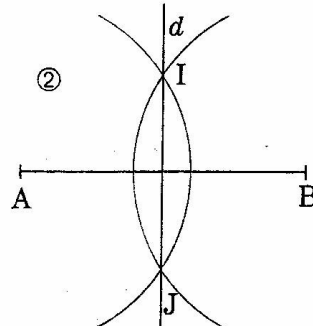
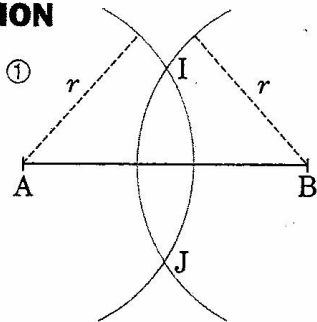
SOLUTION**METHOD**

- ① Draw two arcs of circles *with the same radius*, one centred on A, the other centred on B, which intersect in I and J.
- ② Draw the line (IJ). The line (IJ) is the perpendicular bisector of the segment $[AB]$.

Justification : by construction $IA = IB$, I is a point of the bisector of the segment $[AB]$; for the same reason $JA = JB$, J is a second point of the bisector.

As far as the text is concerned, these two textbooks look similar. However, Textbook 2 indicates a general constraint (the circles must intersect with each other) whereas Textbook 1 gives the solution and says plainly how to get such a result (their radii have to be longer than half the length AB) : the discourse in Textbook 1 seems more on the ‘G1 side’.

Moreover, the diagrams which illustrate the discourse in both textbooks tend to confirm this interpretation : in Textbook 2 one finds only a drawing of the result of the construction, whereas Textbook 1, by giving a realistic representation of the compasses, puts a stress both on the tool and on the gesture. Moreover, Textbook 1 breaks up the action of drawing the two arcs of circles (in fact, they cannot be drawn at the same time) whereas Textbook 2 synthesizes these two actions. And, above all, Textbook 2 gives a justification of the construction, which is totally absent in Textbook 1. Again, it appears that Textbook 1 describes a construction in G1 and remains continuously in G1, whereas Textbook 2 places itself in G2, at least partly.

5. Conclusion

The French geometry curricula, at the end of elementary school and at the beginning of junior high school, appear to be very largely similar in many respects. However they indicate that *‘from the very beginning of the first form, a different*

² Collection Nouveau Décimale. Ed. Belin 2000, p. 185.

*standpoint is directed on geometry*³. From what has just been seen, it appears that the way of teaching geometry at the beginning of junior high school is torn between the two paradigms and that the teachers' concern with the preservation of a continuity in the learning, by keeping to the language in use at elementary school in a new context, may become a didactic obstacle to the students' access to a more theoretical geometry. In particular, giving too much precision in the description of the gestures to be performed to make a 'construction' may conceal the metaphorical role of this language, with the consequence that some students will remain quite a long time in a 'geometry of drawings', as it is still the case with some pre-service schoolteachers. How to enable them to move towards a 'theoretical geometry' is indeed an important question, and we think it worthy of an investigation by researchers.

Bibliography

- Duval R., 1994 : Les différents fonctionnements d'une figure dans une démarche géométrique, in *Repères-IREM* 17, 121-138.
- Edwards L. D., 2002 : The nature of mathematics as viewed from cognitive science, in *Proceedings of CERME 3*.
- Houdement C. & Kuzniak A., 1998 : Trois paradigmes mathématiques, in *Petit x* 51.
- Laborde C. & Capponi B., 1995 : Modélisation à double sens, in *Actes de la Huitième Ecole d'Eté de Didactique des Mathématiques*. Ed. IREM de Clermont-Ferrand.
- Lakoff G. & Núñez R., 2000 : *Where mathematics comes from: How the embodied mind brings mathematics into being*. New York: Basic Books.
- Parzysz B., 2001 : Le mouvement dans la géométrie grecque, in *Bulletin de l'APMEP* 437, 745-762.
- Parzysz B., 2002 : Articulation entre perception et déduction dans une démarche géométrique en PE1, in *Actes du 28ème colloque de la COPIRELEM*. Presses Universitaires d'Orléans, 99-110.
- Presmeg N. C., 1998 : Metaphoric and metonymic signification in mathematics, in *Journal of Mathematical Behavior*, 17(1), 25-32.
- Van Oers B., 2002 : The mathematization of young children's language, in K. Gravemeier, R. Lehrer, B. Van Oers, L. Verschaffel eds. *Symbolizing, Modeling and Tool Use in Mathematics Education*. Kluwer, Dordrecht, 29-58.
- Vygotsky L. S., 1987 : *Thinking and speech*. New York, Plenum.

³ Official document about the first-form mathematics curriculum, published by the French Ministry of Education 1995, p. 39.

MEDIATION OF METAPHORICAL DISCOURSE IN THE REFLECTION ON ONE'S OWN INDIVIDUAL RELATIONSHIP WITH THE TAUGHT DISCIPLINE: AN EXPERIENCE WITH MATHEMATICS TEACHERS

Angela Pesci, University of Pavia, Italy

Abstract: *After recalling some specific meanings related to the role of metaphorical discourse in communication processes, as developed in previous works, the paper reports an experience involving a group of mathematics teachers and centred around the metaphorical and artistic intertwining of mathematics and real life experiences. In particular, metaphors initially chosen by teachers are described: their evolution is then proposed in the specific case of two teachers who made such evolution visible. Final remarks concern an outline of possible developments and further studies on the positive role that metaphorical discourse might play with teachers in favouring a reflection on their own professional experience, on their own motivation to learn and on their own cognitive and communication styles, with the ultimate aim of a follow up in the classroom.*

Keywords: *Mathematics teachers, Verbal and non-verbal Metaphors, Communication, Teachers' personal dimension, Professional development.*

1. Introduction

One of the core matters in the professional training of teachers is the identification of the most suitable intervention modalities, especially in the final phase of the process, which involves adult learners. Cultural knowings, which keep an important role, especially in their metacognitive aspects (for instance being able to reflect on one's own thinking processes, identifying one's own need for knowledge and being able to find answers that fit one's own professional context) are not the only elements to be considered: individuals involved in training, as a whole, are equally important. In this respect, taking into account their previous training experiences, their individual motivation to learn, their specific cognitive qualities, their introspective and interpersonal needs, seems to be an inevitable step.

The experience reported in this contribution was elaborated and realised in collaboration with Anna Gallo Selva, expert in Playback Theatre performing techniques and is widely described in Gallo Selva, A. (2003) and in Pesci, A. (2003a) and synthesised in Gallo Selva A. & Pesci A. (2004). The project meant to conjugate the disciplinary dimension of mathematics with the personal dimension of the involved teachers, with the aim of developing, through metaphorical discourse, a deep awareness of one's own disciplinary and relational resources as well as promoting a welcome attitude towards colleagues and pupils.

This contribution, in particular, shows how some metaphors, initially chosen by teachers to describe their relationship with mathematics, developed throughout the

meetings. However, before getting into this description it is necessary to point out how the role of metaphorical discourse has been interpreted during the whole experience.

2. A possible role for metaphorical discourse

The term *metaphor* comes from the union of two Greek words (*meta*, above and *pherein*, to bring) and points to the transfer of something (a word or else, for instance a gesture) from a main object (which is proper of the word or gesture) to another object, through a more or less implicit comparison. In previous works (Pesci, 2003a) and 2003, b)) some meaningful definitions of the term metaphor were collected, starting from the one proposed by Aristoteles.

In this context, the interesting aspect is an interpretation of metaphor from word to discourse, to be located not only at the verbal level but also at the level of non-verbal communication, referring to gestures, actions, facial expressions, images, objects and sounds.

As detailed in the quoted contributions, metaphorical discourse stimulates listeners to actively orient their thought, because it incorporates two forms of knowledge, the first based on rationality and logic (and mainly connected to the left hemisphere) and the other one based on imagination and creativity (mainly connected to the right hemisphere). The latter form of knowledge proves to be more meaningful, since it acts directly on individuals' emotional part, which is the basis of any cognitive activity (Damasio, 1999; LeDoux, 1998). Hence each metaphor communicates at two levels: a superficial level of discourse content and a deeper level of implicit meanings being evoked. The latter level is given by the use of symbolic language, which is perceived by the unconscious and enacts strictly personal, and often original and meaningful, interpretations.

Hence metaphors, ranging from verbal to artistic ones, become a privileged form of communication, exactly because they are able to communicate with people in depth¹. This is remarkably interesting in the educational context and in particular in relation to mathematics, a discipline which often shapes individuals' personal history in difficult ways.

In this sense it was already pointed out (Pesci, 2003 b) that talking about mathematics to students through symbolic images, actions, gestures, not typical of the world of mathematics but rather of everyday life could promote communication on such a subject. Indeed it is well known that mathematics, because of personal beliefs and stories, could rationally bring emotional blocks, thus impeding comprehension of the simplest ideas and strategies.

Metaphorical discourse could thus have a further value for mathematics education, in addition to those depicted in literature, and propose itself as a mode which could indirectly reach, without encountering the eventual block of the "rational mind", the natural "mathematical spirit" living inside any individual. This paper refers to a work

¹ The efficacy of metaphors in psychotherapy is well known; see for reference texts by P. Barker and D. Gordon quoted in References.

on teachers, who are essential actors on the school scene and thus responsible, often unconsciously, of conflictual relations between their students and mathematics.

Teachers' reflection on their own relationship with mathematics, as developed throughout our project, can be certainly considered as a first step of a subsequent follow up on their attitude in the classroom. This would go in the direction of a clear improvement of communication processes, in favour of both construction of mathematical knowledge and development of positive interpersonal relationships.

3. The experience: a general outline

As detailed in A. Gallo Selva & A. Pesci (2004), the project "The stage in the classroom" involved eight middle school mathematics teachers of Pavia, graduated in Biological, Natural and Geological sciences. Four of them were in-service teachers while the others did only some supply teaching but did not teach during the experience. Their age varied from 26 to 44 years old and all chose freely to be involved in the experience. The project developed in 12 meetings, for a total of 40 hours in a period of about 3 months.

We started with some metaphors from which each participant had to choose the fittest to describe their own personal relation with mathematics, with reference both to their stories as students and their teaching reality.

The following is a list of metaphors among which participants were asked to choose (in case the proposed metaphors were considered inadequate, the teacher could list a sixth, personal metaphor)

1. *being in front of a mountain to climb and not having the suitable equipment*
2. *entering a jungle, with traps that can open up suddenly*
3. *participating in a long marathon*
4. *a challenging game with myself or companions*
5. *being forced to play a boring game*
6.

Starting from the verbal metaphor we then moved to action: everybody has been asked to think about an emotion connected to his story with mathematics and express it through the use of a coloured balloon with a gesture which narrated in a metaverbal mode this emotion and thus "offer" it to the others, creating a dialogue based on looks, postures, perceptions, gestures.

We then proposed the realisation of dialogues where gestures would be connected to unusual sounds: the use of natural numbers in order to favour an empathetic listening to the other.

All these steps, so unusual and far from the everyday classroom practice, took a long time to be assimilated and always needed moments of discussion and verbal exchange.

We then entered the plot of a mathematical question, the duplication of the square (during the 4th and 5th session), asking participants to approach it through a cooperative work and using different materials, so as to favour a "creative" and personal solution strategy.

In this way we recalled the principles of Socratic Maieutics (at the end of the activity, teachers were given the text of Plato's "Menon" related to the considered geometric problem): the knowledge derives from one's own experience and action, the notion must never be a starting point but always an individual and gradual discovery everyone reaches through his own personal resources (this same principle can be found in the *grotowskian* theatre).

After a short autobiographical work based on personal photography, we started to engage in the actual theatrical work, drawing on all the previous experiences: we recalled the metaphors chosen, formed groups based on similar choices and asked to dramatize and represent the metaphor chosen by each group. Importance was given also to the objects each one had brought with relation to the explored issues, as they were symbolic mediation tools related to the emotional impact of each one's own story. After practising with some of the theatrical techniques characterising Playback Theatre (Fox J. & Dauber H., 1999), all the work carried out was translated into a short representation that, far from being a real theatrical play, was still a visible sign of the whole path taken and an instrument to involve a wider audience in the experience.

4. Teachers' metaphors and their transformation

The choice of metaphors on one's own relationship with mathematics as a discipline occurred through the questionnaire described in the previous section, during the second group meeting and after some moments spent in knowing one another.

As regards each one's past as students, the following answers were obtained:

Filippo, Sauro, Silvia R. choose metaphor n. 4, i.e. "*a challenging game with myself or companions*"; Elena and Laura T. choose the same metaphor but delete the expression "*or companions*" in its formulation.

Silvia M. chooses n. 5, referred to a boring game, Laura R. chooses n. 1, the mountain metaphor and Maria Elena, after marking both n. 1 and n. 4, synthesises them in "*being in front of a mountain to climb and not having the suitable equipment and therefore a challenging game with myself, lost at the very beginning*".

In the phase of communicating to others one's own choice, some of the participants add a short comment, to better express their feelings.

Maria Elena, in particular, points out that she tried to put the most negative aspects she found in the proposed metaphors together, because she always felt inadequate at school and she still does at present.

Sauro and Filippo underline that they chose metaphor n. 4 mainly because it involved the word "*game*" and not in the sense of "*challenge*": the latter plays a role, but the main point is the playful and amusing side of mathematics.

Regarding their situation as teachers, the following answers were obtained:

Elena, Filippo and Sauro choose metaphor n. 4; Laura R. and Laura T. make the same choice, but delete the expression "*or companions*" from the original formulation;

Silvia S. in choosing the same metaphor deletes the expression "*challenging*";

Silvia M. proposes the personal metaphor "*to experience a new way of thinking*";

Maria Elena chooses n. 3, related to marathon.

The short comments proposed by the teachers aim at outlining individual relationships with mathematics in more detail: Silvia M., who had chosen the metaphor of a boring game with respect to her past as a student, is now referring to mathematical activity as enabling one to experience new ways of thinking and tackle procedures, although the latter are not particularly “*intriguing*”.

Maria Elena points out that her choice of the marathon metaphor is due to her own perception of doing mathematics as a hard and fatiguing activity, but still a positive one. She adds that she knows well how it feels not to succeed immediately, but she wants to show pupils that “*they can do it*”.

As already mentioned, in subsequent meetings these metaphors and therefore one’s own relationship with mathematics, were linked to objects (both past and present), gestures, actions, stories, improvisation that were regularly solicited by Anna, the group co-ordinator for the performing side, or by other participants.

Particular attention was paid to non verbal languages (for instance proxemics, posture, gestures, over-segmental signs of communication, such as tone, timbre, volume), to moments of observation, listening to and welcome of others: as meetings progressed we could perceive the constitution of a group, almost a new entity progressively defined through each participant’s resources and features, made available for the constitution of one single organism.

During the meetings interpersonal relationships became increasingly more friendly and everyone seemed to feel comfortable.

Also concerning the duplication of the square activity (firstly developed through either individual work or work in pairs, and then through comparison, sharing and comments on proposed solution strategies) everyone acknowledged the relaxed and calm working environment: the group showed a real interest in each solution proposal and therefore everyone felt positively welcomed by others and perceived him/herself as a resource for the overall results of the group.

Starting from the activities, some of the participants shared personal and not always enjoyable memories of their past life, more or less linked to mathematics.

The case of Silvia M. can illustrate this point.

During a meeting aimed at the representation of one’s relationship with mathematics through a sketch, Silvia M. and Elena attempted to illustrate metaphor n. 5 (related to the boring game), chosen by Silvia M. They were arranging a representation in which one of them executed some commands sequentially given by the other: in doing this Silvia M. meant to highlight the intolerant attitude of the one who was executing commands, which were to be given in a peremptory way and not be followed by a positive feedback for any executed action.

In repeating the sketch roles were swapped, gestures were modified in order to identify the most meaningful in terms of the representation, suitable words and voice tones were sought. During the activity, the relationship with mathematics that Silvia M. meant to represent seemed to leave room to a stronger relationship: that with her father. At some point she had claimed that the person who gives commands is “*a precise person, it’s my father*” and had added details on this type of relationship, or

rather on what she defined as the “*emptiness*” of this relationship. The situation had clearly evoked very strong feelings and memories but the group was ready to welcome Silvia M.’s expressions: indeed she felt comfortable to express her feelings, she was aware of the burden represented by her memories, but at the same time she was detached, determined to “*play*” her sorrow on the scene with others.

The title Silvia M. had to give the sketch with the aim to express her relationship with mathematics meaningfully went through a transformation: initially she had chosen “*psychological pressure*” but then, after some meetings, she proposed a simple “*tasks*”, and also her gestures and actions expressed a lower emotional tension.

In the actual performance, everyone was supposed to communicate verbally in a synthetic way their emotion about mathematics to an audience, and move a coloured balloon in the air as they liked, before offering it to the audience. In this case Silvia M. chose the expression “*To me mathematics is experimentation*”. The sign of a change was thus clear, a change from a memory of personal unease to a constructive denotation of the discipline.

It is not in the intentions of this paper to go into deeper interpretations of what happened: however it seems clear that the proposed activity was able to produce a resonance in participants, and involved a number of critical aspects, ranging from personal to professional and disciplinary ones.

During the meetings, in sharing reflections about the carried out experiences, Silvia M. had repeatedly shown her amazement in understanding the importance of non verbal dimension in interpersonal relationships, as able to rouse one’s own lived experiences and thus not to be underestimated in communicating with people (including the classroom).

It is interesting to remark that at the moment of choosing a title for the play, Silvia M. was the only one who had already thought about it and proposed “*More than a thousand words*”, which was enthusiastically accepted by the others, because it captured the central role of the ‘non verbal’ in interpersonal relationships.

In the three months of shared activity, other visible signs of transformation of individual personal relationships with mathematics emerged.

What follows is the interesting case of Maria Elena.

As mentioned earlier in the paper, she had expressed her inadequacy towards mathematics through the metaphor: “*being in front of a mountain to climb and not having the suitable equipment and therefore a challenging game with myself, lost at the very beginning*”. She had repeatedly commented on this feeling through memories of her school years, from which a perception of defeat emerged. During subsequent meetings she had represented the scene expressed by the metaphor with the help of Elena, trying to transfer her feelings of inadequacy and discouragement in gestures, actions and facial expressions. In rehearsing, though, representation of these feelings became less and less tense, gradually lighter and cheerful.

During the duplication of the square activity (only known to Filippo among all the group members), Maria Elena had preferred to work individually, maybe to test her own potential, but it was clear at the beginning that she felt uncomfortable, not sure

to be able to find a solution. She had divided the square into four parts through segments perpendicular to the sides, then she had joined the midpoints of the consecutive sides and observed that the square was thus divided into eight equal triangles. After that she had noticed that the “inner” square consists of four triangles, the “big” one consists of eight triangles and therefore the latter is double the “inner” one.

Only when she presented her own strategy to the others she could realise and express to everybody the role played by the diagonal of the initial square: this diagonal had to become the side of the square to be constructed, which was in this way double the initial square. Maria Elena’s satisfaction was clear: despite her initial hesitation she had managed to find a correct solution strategy.

When in the end Maria Elena had to choose the words to synthesise for the audience her emotion about mathematics through the coloured balloon, she chose “*To me mathematics is quiet anxiety*”, which highlighted how the tension, still present in herself (as expressed by the word “*anxiety*”) was “*quiet*”, perhaps characterised by a higher self-confidence.

It is also interesting to notice that during the project and in subsequent months Maria Elena had attended a course in basic concepts of arithmetic and geometry for mathematics teachers who were not mathematics graduates. She regularly attended the course, actively participating in it, and she got one of the best grades in the assessment of the final examination.

5. Concluding remarks and prospective developments

This concluding section aims at commenting on the main aspects of the described experience, which certainly need further analysis and deepening, but that seem to be promising for those involved in mathematics education and teacher training.

The use of metaphorical discourse, in the wider sense of the term, in the professional training of mathematics teachers is without doubt the most explicit suggestion emerging from the described work.

Mediation of metaphorical discourse in our project was thought and realised at different levels: the first phase, i.e. a rethinking of one’s own life story, was carried out through an explicit use of metaphors. During the subsequent moments of elaboration on one’s emotions and collaborative activities of mathematical inquiry, metaphorical modalities were often used and developed according to participants’ suggestions: all this occurred through both verbal and non verbal languages, such as gestures, images, music, sounds and objects.

The performance offered to an audience was then a translation, in the artistic metaphor, of what the group had elaborated and shared in the experience of common reflection, discussion and planning.

Finally, the whole experience, centred and developed on one’s own personal relationship with the taught discipline, mathematics, was an actual metaphorical path for a possible follow up in the classroom, in the direction of welcoming both pupils and colleagues with particular attention to disciplinary and relational aspects.

Experiences with teachers centred on metaphor as an instrument for self reflection were widely implemented in Italy, starting from the '80s, in disciplines other than mathematics: see, for instance "I laboratori di epistemologia operativa" (Laboratories of operative epistemology) (1994), developed by D. Fabbri and A. Munari.

Regarding mathematics teachers, an increasing amount of research studies use metaphor to explore teachers' thinking (see for instance Cooney et al., 1985; Rogers, 1992; Lim Chap Sam, 1999) but few of them analyse teacher training experiences centred on metaphorical discourse. In this context interesting studies have been led by Chapman, who pointed out that favouring the expression of convictions

"in the form of metaphor could help to facilitate teachers' generation of new perceptions, explanations, and inventions in their teaching of mathematics."

Interesting suggestions for teacher training can be drawn when he claims

"the possible importance of generative metaphors that may underlie mathematics teachers' personal story of growth and the possible significance of consciously attending to such metaphors to assist teachers in achieving desired changes and choices in their teaching." (Chapman, 2001, p. 240).

Another feature of the presented project was the importance attached to autobiographical activities, referred to teachers' life story. Narrative of the self revived in Italy especially in the last decade, as an important educational modality for both students and teachers. Fundamental objectives to be pursued are a positive development of interpersonal communication, reflection on the self, acknowledgement and revisiting of personal facts and features, increased self-listening and self-understanding skills and a consequent increased open attitude toward listening to and welcoming others (Demetrio, 1996 and 1999, Castiglioni, 1999). The efficacy of metaphorical discourse in favouring people to narrate their own life story is widely acknowledged: it permits the necessary detachment from the self (Barker, 1987; Gordon, 1992).

In the project considerable attention was paid to non verbal languages (graphical, pictorial, gestural, ...) both in the construction of mathematical knowledge and in the development of interpersonal relationships: the objective was to realise that unity of mind and body which pedagogues and psychologists suggest as desirable in the whole educational path, but which must be especially recovered in adult age (Gamelli, 2001; Ruggieri, 2001).

The innovative nature, at least in Italy, of the proposal of a theatrical project to teachers is remarkable. Nowadays theatrical projects variously involving pupils and teachers are widespread in our schools, but not equally spread is the proposal of a performing experience to teachers, especially one centred on a discipline like mathematics, which is hardly experienced as a poetic or artistic clue.

As a follow up of the described project a new one is being implemented, still centred on "actors teachers'" relationship with mathematics, in a metaphorical key; this time a different mathematical subject (polyhedra) has been chosen instead of the duplication of the square problem and we aim to a more careful artistic implementation.

The objectives of the completed project, common to the project being implemented with a new group of teachers, can be synthesised as follows:

- To rediscover concrete, playful, curious and poetic aspects of mathematics
- To offer an alternative expressive modality to re-interpret one's everyday professional and personal experience creatively
- To develop a process of reflection, by participants, on their own taught discipline, to re-discover their motivations to learn and their cognitive and metacognitive resources, in the direction of teachers' continuing education
- To favour the acquisition of instruments and modalities of empathetic welcoming of individuals (colleagues, parents, pupils) included in collective dynamics of the school environment
- To stimulate a follow up of the experimented path on one's teaching model in relation to one's pupils, both at disciplinary and relational level
- To set up an experience that can be enjoyed outside the mathematical context, through the presentation of a theatrical play, in order to promote a positive approach to mathematics and remove the usual prejudices attached to it, thus enacting a process of "humanistic" re-definition of the subject matter.

The project might address not only participant mathematics teachers, but also other trainee and in-service mathematics teachers as well as students from all school levels that might be involved, through the fruition of the theatrical event, in related specific moments of reflection and debate.

A wider audience might also participate in the performance, in extra-school contexts (theatrical spaces, festivals, ...), thus experiencing an approach to mathematics that is not exclusively rational but emotionally, aesthetically and creatively involving, in the broader direction of promotion of scientific thinking.

References

- Barker, P.: 1987, *L'uso della metafora in psicoterapia*, Astrolabio, Roma. Original Title: *Using Metaphors in Psychotherapy*, Brunner/Mazel Publ., NY, 1985
- Castiglioni, M.: 1999, *L'ascolto biografico, L'educatore auto(bio)grafo Il metodo delle storie di vita nelle relazioni d'aiuto*, a cura di D. Demetrio, Unicopli
- Chapman, O.: 1998, Metaphor as a tool in facilitating preservice teacher development in mathematical problem solving, *Proc.PME 22*, Stellenbosch, Vol. 2, 176-183
- Chapman, O.: 2001, Understanding high school mathematics teacher growth, *Proceedings PME 25*, Utrecht, Vol. 2, 233-240
- Cooney, T., Goffrey, F., Stephrns, M. & Nickson, M.: 1985, The professional life of teachers, *For the Learning of Mathematics*, 5 (2), 24-30
- Damasio, A. R.: 1999, *The Feeling of What Happens*, New York/San Diego/London, Harcourt Brace & Company
- Demetrio, D.: 1996, *Raccontarsi. L'autobiografia come cura di sé*, Cortina, Milano
- Demetrio, D., (ed.): 1999, *L'educatore auto(bio)grafo Il metodo delle storie di vita nelle relazioni d'aiuto*, Unicopli

- Fabbri, D. & Munari, A.: 2000, I laboratori di epistemologia operativa, in *Apprendere nelle organizzazioni, Proposte per la crescita cognitiva in età adulta*, D. Demetrio (ed.), Carocci, Roma, 239-251
- Fox, J. & Dauber, H., (eds.), 1999, *Gathering Voices Essays on Playback Theatre*, Tusitala Publication, NY
- Furinghetti, F., Pesci, A. & Zan R.: 2004, Affect in Mathematics Learning and Teaching, L. Cannizzaro, A. Pesci & O. Robutti (eds.), *Research and Teacher Training in Mathematics Education in Italy: 2000-2003*, Ghisetti&Corvi Editori, Milano
- Gallo Selva, A.: 2003, Dire, Fare, Contare, *Tesi di Master in "Linguaggi non verbali e della performance"*, Università di Venezia
- Gallo Selva, A., Pesci, A.: 2004, Taking into account metaphors, autobiographies and non verbal languages in the professional training of mathematics teachers, A. Rogerson (Ed.), *Proc.7th International Conf. of the Mathematics Education into the 21st Century Project, The Future of Mathematics Education*, 119-122
- Gamelli, I.: 2001, *Pedagogia del corpo*, Meltemi
- Gordon, D.: 1978, *Therapeutic Metaphors Helping Others Through the Looking Glass*, Meta Publications, Cupertino, California
- Grotowski, J.: 1980, *Per un teatro povero*, Bulzoni, Roma
- Lakoff, G. & Nuñez, R. E.: 2000, *Where Mathematics Comes From, How the Embodied Mind Brings Mathematics into Being*, Basic Books, New York
- Lapierre, A. & Aucouturier, B.: *La simbologia del movimento*, Edipsicol., Cremona
- LeDoux, J.: 1998, *The Emotional Brain*, Phoenix, Orion Books Ltd.
- Lim Chap Sam: 1999, Using metaphor analysis to explore adults' images of mathematics, *Philosophy of Mathematics Education Journal*, n.12
- Parzysz, B., Bergsten, C., Matos, J. M. & Pesci A.: 2003, Role of metaphors and images in learning and teaching, *Proceedings of Cerme 3*, Bellaria, <http://www.dm.unipi.it/~didattica/CERME/proceedings>
- Pesci, A.: 2003 a), La classe come palcoscenico, *Tesi di Master in "Linguaggi non verbali e della performance"*, Università di Venezia
- Pesci, A.: 2003 b), Could metaphorical discourse be useful for analysing and transforming individuals' relationship with mathematics?, *Proc.6th Intern. Conf. of the Mathematics Education into the 21st Century Project, The Decidable and the Undecidable in Mathematics*, A. Rogerson (Ed.), 224-230
- Rogers, L.: 1992, Images, metaphors and intuitive ways of knowing: the contexts of learners, teachers and of mathematics, F. Sieger & H. Steinbring (eds.), *Proc. of the 4th Conference SCTP*, Brakel, Germany.
- Ruggieri, V.: 2001, *L'identità in psicologia e teatro*, Ed.Scientifiche Magi, Roma

BUILDING VISUAL STRUCTURES IN ARITHMETICAL KNOWLEDGE – A THEORETICAL CHARACTERIZATION OF YOUNG STUDENTS' "VISUAL STRUCTURIZING ABILITY (VISA)"

Elke Söbbeke, *University of Essen, Germany*

Abstract: *In the process of learning elementary arithmetical mathematics, visual representations are used to build efficient and adequate internal systems of representation in young students' minds. But, the semiotic representation must not be confused with the mathematical object. Visual representations are signs and symbols, which have to be interpreted. In this paper an empirical study is presented, which had analysed the conceptual role which a representation acquires in the process of children's interpretation and in how far the learning child succeeded in building structures and relations into the visual diagram.*

Keywords: *representation, sign/symbol, children's interpretation, building structures and relations into diagrams, empirical study*

1 Theoretical Background

In the process of mathematics teaching in elementary school, the use of visual representations is an important foundation to help young students in building mental, internal representations of mathematical ideas. Goldin und Shteingold (2001) described „the development of efficient (internal) systems of representation in students, that correspond coherently to, and interact well with, the (external) conventionally established systems of mathematics” as a fundamental aim for the process of mathematics teaching (Goldin & Shteingold, 2001, p. 3).

But this aim implies a difficult and highbrow task for the teacher: As different education studies in mathematics have shown, the intended way from the external to the internal, mental representations is not straight, easy and above all not clear (unequivocal) (cf. Lorenz 1998, Schipper 1984). But in contrast to that, in the everyday mathematics lessons, a unreflected culture of interaction (for example in strong adherence to Bruner's e-i-s-principle) often causes that such representations are used in a standardized and schematic way, to prevent all ambivalence (cf. Voigt 1993, Steinbring 1994). In traditional teaching, the use and the function of representations are reduced to a methodical aspect (vgl. Jahnke, 1984, p. 39), through which the special epistemological quality of mathematical knowledge and the symbolic character of representations are ignored.

Mathematics, as a science of patterns, relations and structures, cannot be grasped or learned in an empirical way. The only way of gaining access to mathematical knowledge is in using signs, symbols, or visual representations. The mathematical ideas, as “theoretical ideas, are not things, which could be conveyed as completed products. The mathematical subject consist of relations between things and not in the objects and its properties. Therefore, mathematical thinking (...) has to be visualized,

in order to represent such relations” (Otte, 1983, p. 190; translated). Representations are not mere images, but symbols. They contain complex relations, which the learning child has to comprehend in two ways: taking into account the overall structure, and simultaneously its multi-faceted individual aspects. In an interactive process the young students have to construe relations into the diagram, and by way of construing meaning into these new relations, the mathematical knowledge has to be developed in a rather abstract way (cf. Steinbring, 2005).

Connected with the epistemological function of mathematical representations, there is a special quality in the relation between the established ideas and systems of mathematics and their visual representation. On the one hand there is the mathematical knowledge, which has to be represented in diagrams, materials, or symbols. On the other hand, the semiotic representation must not be confused with the mathematical object. Raymond Duval describes this as the „paradoxical character of mathematical knowledge“: „(...) there is an important gap between mathematical knowledge and the knowledge in other sciences such as astronomy, physics, biology, or botany. We do not have any perceptive or instrumental access to mathematical objects, even the most elementary (...). We can not see them, study them through a microscope or take a picture of them. The only way of gaining access to them is using signs, words, or symbols, expressions or drawings. But, at the same time, mathematical objects must not be confused with the used semiotic representation. This conflicting requirement makes the specific core of mathematical knowledge” (Duval, 2000, p. 61).

Therefore visual representations are signs and symbols, which have to be interpreted. To build new mathematical knowledge it is necessary to disregard the concrete properties and to examine the relations, structures and the theoretical ambivalence which a mathematical representation contains. The main interest in the research of this author’s empirical study is in this area of changing interpretation, between an empirical view on concrete objects and an abstract view on relations and structures.

2 Method of the Empirical Study

2.1 The Input of Data

Within the scope of the study, the theoretical construct of „*Visual Structurizing Ability (ViSA)*” has been developed, as a central research concept. It reflects the theoretical foundation and characterizes the dimension of ability to build – in an active process of interpretation – structures and relations into a visual representation.

The main interest of research pertains to the role which the representation acquires in the process of children’s interpretation and to the relations and structures which the learning child succeeds in building into the visual representation. Therefore, processes of interpretation had to be initiated. The data input had been carried out with clinical interviews (cf. e.g. Hunting 1997), which had been held with 15 children age 6 to 10. In three different groups of tasks the children had been asked to find

calculations which correspond to a presented diagram, or, on the other side, to draw a corresponding diagram to a presented calculation. In a third group, the children solved tasks in which it was useful and effective to build structures into the diagram.¹

2.2 The Analysis of Data

An important orientation of analysis is, that representations are not *self evident* and explain *automatically* a new mathematical subject, but in principle constitute signs and symbols for the learning child. From this perspective, graphic representations are much more than images, they are symbols (cf. Jahnke 1984, p. 35), which have to be interpreted. Therefore during a learning process, a representation can hold two different roles: At first, it can constitute a *familiar context*, which helps the child to comprehend new mathematical subjects. At second, the representation can also be a *new symbol* for the child, which has to be interpreted with contexts that are more familiar to him (for example, arithmetic contexts).

In the analysis of the clinical interviews, the focus lies on the culture of the symbolic use of such media, and on the fundamental relationship between the child, as a psychological and social subject, the representation, as an object of interaction and the child's growing mathematical-cultural concept of interpretation. In this process of mediation and active interpretation there can be found many different aspects of empirical and/or structural appreciation. To do justice to *both* of these perspectives, a new method of analysis has been developed, which implies two complementary qualitative instruments of analysis: on the one hand an *epistemological* method, using Steinbring's *epistemological triangle* (cf. Steinbring 2005), on the other hand a system of detailed categories of analysis.

1st Instrument: „The *Epistemological Triangle*“

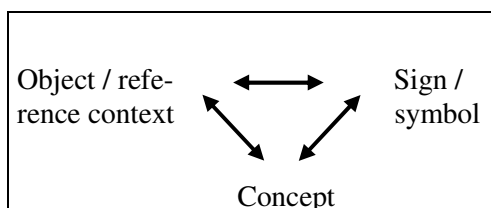

fig. 1: The epistemological triangle (cf. Steinbring 2005)

Mathematical knowledge has to be represented with signs and symbols (cf. section 1). On the other hand these systems of signs and symbols need familiar contexts of reference, to receive meaning (cf. Steinbring 2005, p. 24f.). Seen in an epistemological view, the building of new mathematical knowledge is an active interpretation of the relationship between these symbols and their

contexts of reference. Mathematics, with its stock of concepts, terms and rules, grown in a social and historical process, cannot be comprehended in an exclusive individual process, but only in an *interactive* and *social* process of building sense (cf. Steinbring, 2005). The epistemological triangle is an instrument to describe and analyse this scope.

¹ Altogether every single child had been working on ten different tasks.

In this empirical study, the epistemological triangle has been used to analyse systematically the conceptual role which the representations acquire in the process of children’s interpretation. It has been used to examine *if, when* and *in which way* the representation is a familiar context or new symbol for the child.

2nd Instrument: „The Model of Categories of Analysis“

In a second step, a detailed model of categories has been reconstructed from the data of the clinical interviews. The categories have been the primary foundation to analyse in how far the learning child succeeded in building structures and relations into the visual diagram.

The aim of this study is not to prove an existing hypothesis, but – from an explorative view – in generating a (new) theory of “Visual Structurizing Ability (ViSA)”. Considering this aim and the relevant literature, a reconstructive and hypothesis-generating method has been chosen, which had been developed from the sociologist Bohnsack (cf. Bohnsack 2000). The analyses aim to reconstruct young students’ strategies in using, interpreting, and structurizing visual representations. Through systematic comparative analyses, it was possible to define different categories of ViSA. This has been the first foundation to generate the new theory of ViSA.

In the following diagram the model of categories of ViSA is presented. The single categories describe fundamental and important characteristics of the children’s individual strategies. In the model two main groups of abilities are separated: 1st group: “Visual Structurizing”, 2nd group: “Determining numbers”. In both groups there is a further separation.

In group 1: the categories list on the *left side* describe the *type* of elements, which the child builds into the diagram. For example, the child uses “*single elements*”, or “*individual structures*” or “*intended structures*”. The “*intended structures*” correspond to structures, which are layed out in the didactical representation; in contrast the individual structures are construed in an individual manner, which show no relation to intended structures of the diagram. The column on the *right side* shows categories, which describe the *way* the children use their elements. For example, the child uses elements as “*concrete objects*” (without building any relations between them), or uses “*relations*” between elements, or uses “*re-organisations*”.

| Visual Structurizing | |
|--------------------------------|---|
| Elements of Interpretation | Way of Using the Elements of Interpretation |
| Building single elements | Use as concrete objects |
| Building individual structures | Use with a very separating character |
| Building intended structures | Use with partial overlaps |
| Building substructures | Use with partial gaps |
| | Use of parts / sections of diagram |
| | Use of structural relations |
| | Use with coordinating elements |

| | |
|---|---|
| | Use with re-organisation / re-interpretation elements |
| Determining numbers | |
| Counting numbers | Grasping numbers |
| Counting in an unstructured way | Grasping simultaneously |
| Counting in a structured way | Grasping quasi-simultaneously |
| Counting in steps | Grasping on the basis of structures |
| Counting with the individual structures | |
| Counting with the intended structures | |
| Counting with the substructure | |

Fig. 2: Model of categories of ViSA

3 Results

Considering the carefully and detailedly analysed interviews (with the use of the categories of analysis) and the relevant studies in the literature, it was possible to distinguish different *qualities* of the childrens interpretations. In this process *four types* of childrens interpretations could be separated. These different qualities are pointed out and described in the “*Four Levels of Visual Structurizing Ability*”:

| | |
|------------|---|
| Level I: | Level of concrete and empirical Interpretation |
| Level II: | Level of Mediation between partial Empirical Interpretation and first Structural Interpretation |
| Level III: | Level of Structural Interpretation with Increasing and Flexible Use of Relations and Re-Organisations. |
| Level IV: | Level of Structural and Relational Interpretations, with Extensive Use of Relations and Flexible Re-Organisations |

This model of four Levels of ViSA is one of the main results of the empirical study. The four levels can be seen as an accentuation and reduction to the *most* important characteristics of ViSA. From this perspective they allow at the same time a concentration and overview of ViSA in the children’s different phases of interpreting a representation.

But an important orientation for using this model has to be pointed out: The four levels must not be comprehended as determined levels in a genetic way. Children do not have to go through them in a fixed order. The assignment of a child’s interpretation to a level of ViSA does not identify its abilities in a *generalised* way, but it draws a differentiated image, which shows the *spectrum* of the child’s appreciations to a representation. Therefore, the assignment must always be seen in relation to the *specific context of task* and to the *specific phase of interpretation* (beginning or end of interpretation process), in which the child acts.

In the following section the most characteristic aspects of the four levels of ViSA are described and explained with exemplary and short parts of the clinical interviews.

Jennifer finds the calculation „1+5=6“ to the numberline Z1²

In the interview Jennifer has been asked to find a arithmetica task, which correspond to the given diagram. Jennifer notes the calculation „1+5=6“ and explains her decision:

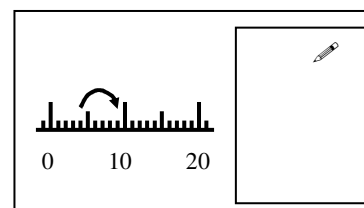

Fig. 4: numberline Z1

14 Je So here, where the, where that [runs her finger over the arrow's beginning] other black bow is, there...
 15 I Yes.
 16 Je ...I see the one [runs her finger down to mark S4].

24 Je There I can [points to mark S5] easily count 1, 2, 3, 4, 5 [points to the marks S 5, 6, 7, 8, 9]
 25 I Mhm.
 28 Je ... and then I can calculate one plus five is six [points to the scratchpaper on the interviewpaper].

In Jennifer's interpretation the arrow constitutes no structural element of the representation. It is used as a „meta-sign“, which brings special elements of the representation out and isolates them (6 marks

under the arrow), in order to build the calculation. Jennifer does *not use the whole representation*, but concentrates on single and *concrete aspects*, which can be grasped in an empirical way. But between these objects, she builds *individual structures* (“1” and “5”) and uses *elementar relations* and *coordinations*. There is *no re-organisation* of structures.

Level III: Level of Structural Interpretation with Increasing and Flexible Use of Relations and Re-Organisations.

In interpretations on this level, *individual* and *intended* structures and relations can be identified. On this occasion different and multi-faceted aspects of the representation are recognised. In comparison to level II, the structures are *manifoldly coordinated* and more *flexibly re-organised*. The structures are no longer isolated, but seen as part of the whole and separated and put together in a structural way. You always find the use of *structural relations*, *coordinations* and *re-organisations* of elements. In all, this level III of ViSA can be characterized by the combination of building structures with the increasing use of relations and re-organisations. Level III could be identified in the following interview-scene:

Jennifer interpretes the mark „S11“ in the numberline Z3

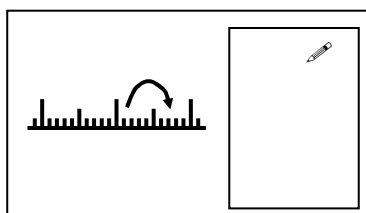

In a first interpretation, Jennifer has named the mark “S11” as the number „11“. The interviewer calls Jennifer's attention to the missing inscription under the numberline and asks her, if this mark (S11) could represent another number as well. After that, Jennifer develops different

Fig. 5: numberline Z3

² To describe the diagram, the marks in the numberline have been numbered from left (beginning at “-1”), to right: S(-1), S0, S1, ..., S21.

interpretations of the mark „S11“ and designates it as the numbers „11“, „101“ und „1001“. She explains her solution as follows:

- 146 Je Yes, because that really could be everything [*runs her finger from left to right below the numberline-diagram*]. It could, eh, because there really is only the 10th-series [*points to mark S0, moves the pencil from mark S0 to S5*] and here the 100th-series and perhaps the 1000th-series.
- 147 I Mhm.
- 148 Je So, the 1000th -series it really could not be.
- 149 I Why not?
- 150 Je Tshe, it really could be everything [*points to the numberline*]. So, but you don't know it, if there are no numbers placed [*points to the numberline*].

In comparison to Jennifer's first interpretation „ $1+5=6$ “ (cf. level II) she now develops in this phase multiple *re-interpretations* by building different *intended structures* into the diagram. Her interpretations are no longer tied to concrete objects, but the marks in the diagram represent different numbers, which cannot immediately be seen or grasped in an empirical way.

Level IV: Level of Structural and Relational Interpretations, with Extensive Use of Relations and Flexible Re-Organisations

On this level, only *intended structures* can be identified, which are built in the process of interpretation. All these interpretations can be characterized by a *very structural* and *relational* view on the representation, by building *extensive relations and coordinations* between elements and using *extensive, flexible re-organisations*. An example is shown in the following interview scene:

*Katrin develops a new strategy of determining number of triangles*³

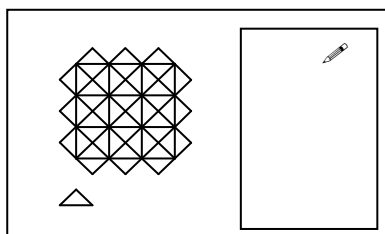

Fig. 6: Interviewpaper
„How many triangles?“

In the first phase of interpretation Katrin has built individual structures into the diagram and counted the number of triangles using single elements (triangles). In the next phase she develops a *new strategy*, by structurizing the diagram into an interiorzone and a border zone. Further, she builds squarestructure-elements into the interior zone, which contain in each case four triangles. Katrin builds *manifold relations* between these elements and *coordinates* them in an effectiv way to determine the number of triangles in the interior zone. After that, Katrin *coordinates* the number of “border triangles” (“12”) and “interior triangles” (“36”) to acquire the number in the whole diagram (“48”).

- 14 Ka Mhm, if you, if you here four [*moves her pencil circulary over square Q1 (Fig. 6)*]
- 15 I Mhm.

³ This interview task had been developed (with little alterations), following the “*Tiled Floor Problem*” by Marja Van den Heuvel-Panhuizen (cf. 1996, p. 71).

16 Ka [moves the pencil over the interiorzone, points the pencil on the squares Q3,6,9,8,5,2,1,4,7, while very quietly whispering] sixn, that are 36 [moves the pencil over the diagram].

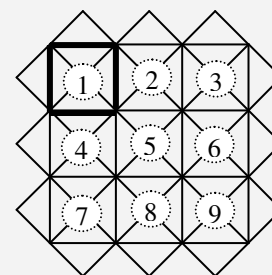

Fig. 6: Diagram with numbering of squares in the interiorzone (Q1 – Q9)

17 I Mhm.

18 Ka And those outside are 12 [points over the left below border of the diagram]

4 Resumé

The combination of the detailed two-stage analyses with the classification of the visual structuring ability in form of the four described levels, enables to demonstrate the rich spectrum, in which young students' processes of interpretation of representations can take place. Within this spectrum a manifold and great variety of approaches and interpretations could be identified:

1.) This richness and variety refers on the one hand, to the *role* of *sign/symbol* and *reference context*. The reference context is *not* given a priori, in form of an obviously "readable" or "clear" meaning of the diagram, but – in contrast to that – it is designed and re-organised by the learning child, in the course of the process of interpretation. The process of interpretation must be understood as a mediation between the historically and socially emerged form and structure of the signs/symbols and the individual interpretation of the meaning of the signs/symbols. In the progressive development of mathematical knowledge, especially through the mediation between the reference context and the sign/symbol the new mathematical concept develops, by assigning interpretations from a familiar reference context to a new sign/symbol.

2.) On the other hand, this variety of young students' approaches to the interpretation of a representation, implies that such media – even when used in the mathematics teaching – are partly still unexplored, and have to be subjected to a *new* process of interpretation. In this regard, more than a half of all interpretations (in the research study) could be assigned to the *second* level of the ViSA. This level has to be seen as a level of transition, in which no longer purely empirical approaches dominate, but first structures are build. It becomes clear, that the children's abilities of interpretation on this level, contain a substantial potential, which is often not noticed in an adequate manner in everyday mathematics instruction in the primary school.

The results of the study establish an important and deeper insight into the fundamental relationship between the child, as a psychological and social subject, the representation, as an object of interaction and the young students developing mathematical-cultural concept. On this basis it is essential for the didactical use of representations, to reflect carefully the complex conditions, which had been worked out by the four levels of ViSA, and in the same way, the children's abilities of visual structurizing, in order to add specific supporting measures. The results of the study

emphasize that such a support must be more than “learning in a traditional sense” or “memorizing given interpretations”. The use of representations has to be seen as an epistemological, social and interactive demand. By the way, this view on representations should initiate and enable the children to deal actively with the theoretical ambiguity, with structures and relations in a representation. Thus, a new aspect for the didactical use of representations is shown: Not only for the learning child it is a special requirement to handle and interpret a representation. In fact, the organization of this handling, is a very special challenge for the teacher, because it requires an new attitude, regarding the ambiguity of such media.

5 References

- Bohnsack, R.: 2000, ‘Rekonstruktive Sozialforschung: Einführung in Methodologie und Praxis qualitativer Forschung’, Leske + Budrich, Opladen.
- Duval, R.: 2000, ‘Basic Issues for Research in Mathematics Education’, in T. Nakahara & M. Koyama (ed.), *Proceedings of the 24th International Conference for the Psychology of Mathematics Education*, V.I. Hiroshima, Japan: Nishiki Print Co., Ltd, 55-69.
- Goldin, G. & Shteingold, N.: 2001, ‘Systems of Representations and the Development of Mathematical Concepts’, in Cuoco, A. A. and Curcio, F. R. (ed.), *The Roles of Representation in School Mathematics*, NCTM Yearbook. Boston, Virginia, 1-23.
- Heuvel-Panhuizen, M. van den: 1996, ‘Assessment and realistic mathematics Education’, CD-β Press, Center for Science and Mathematics Education, Utrecht.
- Hunting, R. P.: 1997, ‘Clinical Interview. Methods in Mathematics Education Research and Practice’, in *Journal of Mathematical Behavior* 16 (2), 145-165.
- Jahnke, H. N.: 1984, ‘Anschauung und Begründung in der Schulmathematik’, in *Beiträge zum Mathematikunterricht*, Bad Salzdetfurth, 32-41.
- Lorenz, J. H.: 1998, ‘Anschauung und Veranschaulichungsmittel im Mathematikunterricht. Mentales visuelles Operieren und Rechnleistung’, Hogrefe, Göttingen.
- Otte, M.: 1983, ‘Texte und Mittel’, in *Zentralblatt für Did. d. Math.*, 4, 183-194.
- Schipper, W. & Hülshoff, A.: 1984, ‘Wie anschaulich sind Veranschaulichungshilfen?’, in *Grundschule* 16 (4), 54-56.
- Steinbring, H.: 1994, ‘Die Verwendung strukturierter Diagramme im Arithmetikunterricht der Grundschule. Zum Unterschied zwischen empirischer und theoretischer Mehrdeutigkeit mathematischer Zeichen’, in *MUP, IV. Quartal*, 7-19.
- Steinbring, H.: 2005, ‘The Construction of New Mathematical Knowledge in Classroom Interaction – an Epistemological Perspective’, *Mathematics Education Library (MELI)*, No. 38, Springer, Berlin, Heidelberg.
- Voigt, J.: 1993, ‘Unterschiedliche Deutungen bildlicher Darstellungen zwischen Lehrerin und Schülern’, in Lorenz, J. H. (ed.), *Mathematik und Anschauung. Untersuchungen zum Mathematikunterricht*. Aulis Verlag, Köln, 147-166.

THE EFFECT OF MENTAL MODELS (“GRUNDVORSTELLUNGEN”) FOR THE DEVELOPMENT OF MATHEMATICAL COMPETENCIES. FIRST RESULTS OF THE LONGITUDINAL STUDY PALMA

Rudolf vom Hofe, *University of Regensburg, Germany*

Michael Kleine, *University of Regensburg, Germany*

Werner Blum, *University of Kassel, Germany*

Reinhard Pekrun, *University of Munich, Germany*

Abstract: *Grundvorstellungen, shortly GVs, are mental models of mathematical concepts which are important for serious kinds of mathematical thinking. Investigations into the development of GVs and their role for the mathematical achievement of students are combined with many methodological and conceptual problems. On the basis of a large scale longitudinal project we (1) describe the role of GVs for the process of mathematical modelling, (2) discuss problems of test construction, and (3) report on some preliminary results concerning the development of modelling competency during the first two years of secondary school (11-13 year-olds).*

Keywords: *Grundvorstellungen, mental models, mathematical literacy, long term studies, large scale assessment*

On the Concept of Grundvorstellungen

Experiences both with lessons and empirical research show that essential reasons for some serious problems of mathematical understanding are caused by conflicts concerning the intuitive level (cp. Fischbein, 1987 or 1989). Essential reasons of these problems are based in the fact that often mathematical concepts and symbols are filled by students with a totally different meaning from what is intended by the teacher. In order to counteract these problems, different concepts of the generation of "mental models" have been developed which emphasize the *constitution of meaning* as a central aim of mathematics teaching. In Germany mental models which are carrying the meaning of mathematical concepts or procedures are called *Grundvorstellungen*, shortly *GVs*.

Concepts of *GVs* have a long tradition in the history of mathematics education in Germany, and there is also much actual research on *GVs* concerning all school grades

(see for more details vom Hofe, 1998, and Blum, 1998). Naturally, such concepts are not restricted to the German speaking area, but can be found in many other countries as well (cp. for example the concept of “intuitive meaning” (Fischbein, 1987), “use meaning” (Usiskin, 1991) or “inherent meaning” (Noss, 1994).

In mathematical education research the term GV is used both in a prescriptive and a descriptive way: GVs as a *prescriptive notion* describe adequate interpretations of the core of the respective mathematical contents which are intended by the teacher in order to combine the level of formal calculating with corresponding real live contexts. In contrast, in descriptive empirical studies the term GV is used also as a *descriptive notion* to describe ideas and images which students actually have and which usually more or less differ from the GVs intended by mathematical instruction.

Examples of elementary GVs:

- *Subtracting* as (a) taking away, or (b) supplementing, or (c) comparing;
- *Dividing* as (a) splitting up or (b) sharing out.
- *Fractional number* as (a) part of a whole, or (b) operator, or (c) ratio.

GVs can be interpreted as elements of connection or as objects of transition between the world of mathematics and the individual world of thinking. In this context “generation of GVs” does *not* mean sampling a collection of static mental models which are valid forever. Quite the reverse, the generation of GVs in the long run is a dynamic process in which there are changes, reinterpretations and substantial modifications. Especially if the individual is going to be involved with new mathematical subjects, she or he will have to modify and extend her or his system of mental models, otherwise GVs which have been successful for so long could become misleading “tacit models” (referring to Fischbein, 1989) when dealing with new mathematical subjects.

The generation of GVs is especially important for the mathematical concept development, characterising three aspects of this process:

- *constitution of meaning of mathematical concepts* based on familiar contexts and experiences,
- *generation of generalised mental representations* of the concept which make operative thinking (in the Piagetian sense) possible,
- *ability to apply a concept to reality* by recognizing the respective structure in real life contexts or by modelling a real life situation with the aid of the mathematical structure.

Thus the generation of a dynamic network of GVs is an important prerequisite for the development of mathematical competence as a whole. Without GVs however mathematical operation becomes a lifeless formalism which is cut from the areas of application and reality.

Because of their mental nature, it is naturally difficult to explore student's GVs by empirical research and there are many theoretical and methodological problems of getting insight into student's mental models. But regardless to these problems the development of working methods for empirical based analysing of mathematical thinking is an important issue of mathematics education. In the following we introduce a longitudinal study which is conceptually based on the idea of GVs. Furthermore we will elaborate a little more the role of GVs for mathematical modelling.

Design of PALMA

TIMSS and PISA have documented considerable differences in students' achievements in mathematics, which lead to lively discussions concerning the effectiveness of the teaching of mathematics in school. However, these studies have some serious deficiencies which only partly explain the causes for differences in achievement. Studies like TIMSS and PISA are essentially producing a descriptive system monitoring concerning specific measuring moments and age groups. But due to their descriptive, cross-sectional design, they cannot provide insights into the *mathematical achievement development* which has led to the stated results, nor into the impact of corresponding GVs. Especially these points, however, are important in providing causes for the identified achievement deficits and evidence for possibilities for the improvement of classroom practice.

Thus the aim of the research project PALMA (*Project for the Analysis of Learning and Achievement in Mathematics*) is to pursue longitudinally students' mathematical achievement and its conditions. Essential aims are (1) the analysis of mathematical achievement development and corresponding GVs from grade 5 to 10, (2) the analysis of causes of this development, and (3) providing hints for the improvement of teaching and learning of mathematics in this age group. In addition to mathematical achievement variables, we assess important psycho-social characteristics as potential causes for differences in achievement through students' self-reports as well as information on family background and instructional processes through parent and teacher questionnaires, and we have interview sessions with individual students.

The basic sample of PALMA encloses $N=2070$ students in 83 classes, their parents and mathematics teachers. The first survey took place in summer 2002. In 2006, our student population will be equivalent to the third PISA wave (see fig. 1).

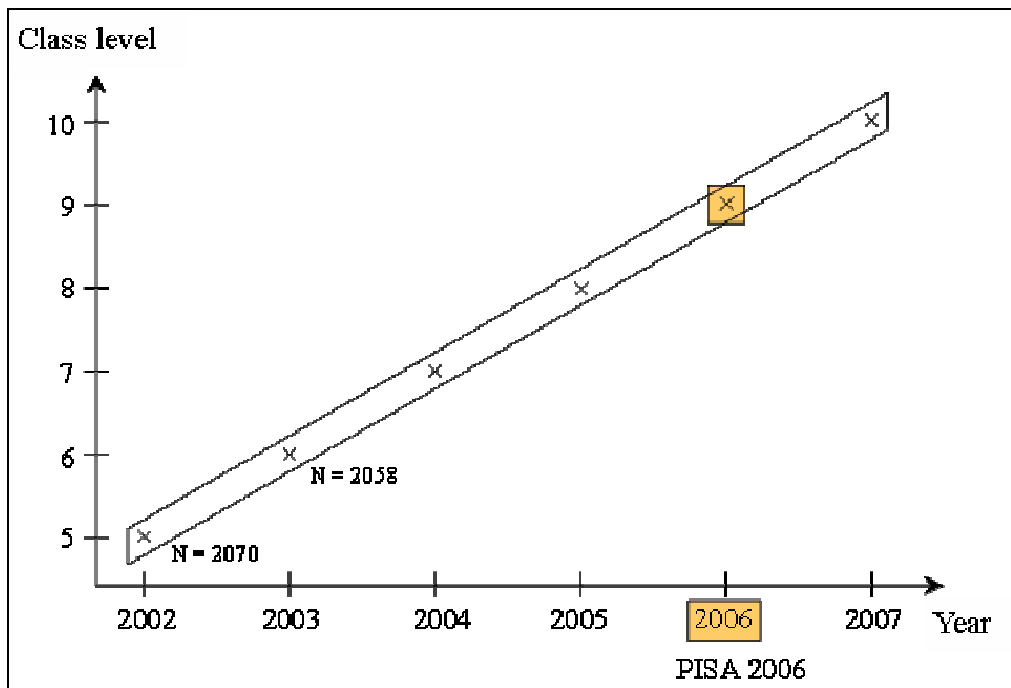

Figure 1: Project Design

In this paper we would like to discuss briefly some methodological and conceptual questions of mathematical achievement development and provide some first results of PALMA. Concerning the psycho-social topics we refer to Pekrun et al., 2002. We are now concerned especially with the following questions:

What is the role of GVs for the process of mathematical modelling and for mathematical literacy in general?

To what extent can we get insights into characteristics of students' achievement development and its problems?

What results for improving teaching and learning of mathematics can be expected?

Conceptual Basis

In PISA, basic mathematical education is described as 'mathematical literacy' (OECD, 1999) which emphasises the role of conceptual understanding and meaningful application of mathematics in contrast to mere algorithmic calculating and formula manipulating. Dealing with mathematics in that way stresses the importance of *modelling* as a mayor mathematical competency. The following figure simplistically illustrates the typical steps of a modelling process and shows its cycle character (see fig. 2); for more details see Blum, 2002.

When carrying out this process, *translating between the real world and mathematics* is a main mathematical activity, for example finding mathematical concepts or procedures which represent a given real life context on the mathematical level or

interpreting what a mathematical solution means for the real world situation. Therefore GVs are needed which carry the meaning of mathematical notions and procedures and so enable the student to move mentally between mathematics and reality (cp. Freudenthal, 1983). The generation of a linked-up system of appropriate GVs is therefore a major precondition for successful mathematical modelling in the sense of mathematical literacy.

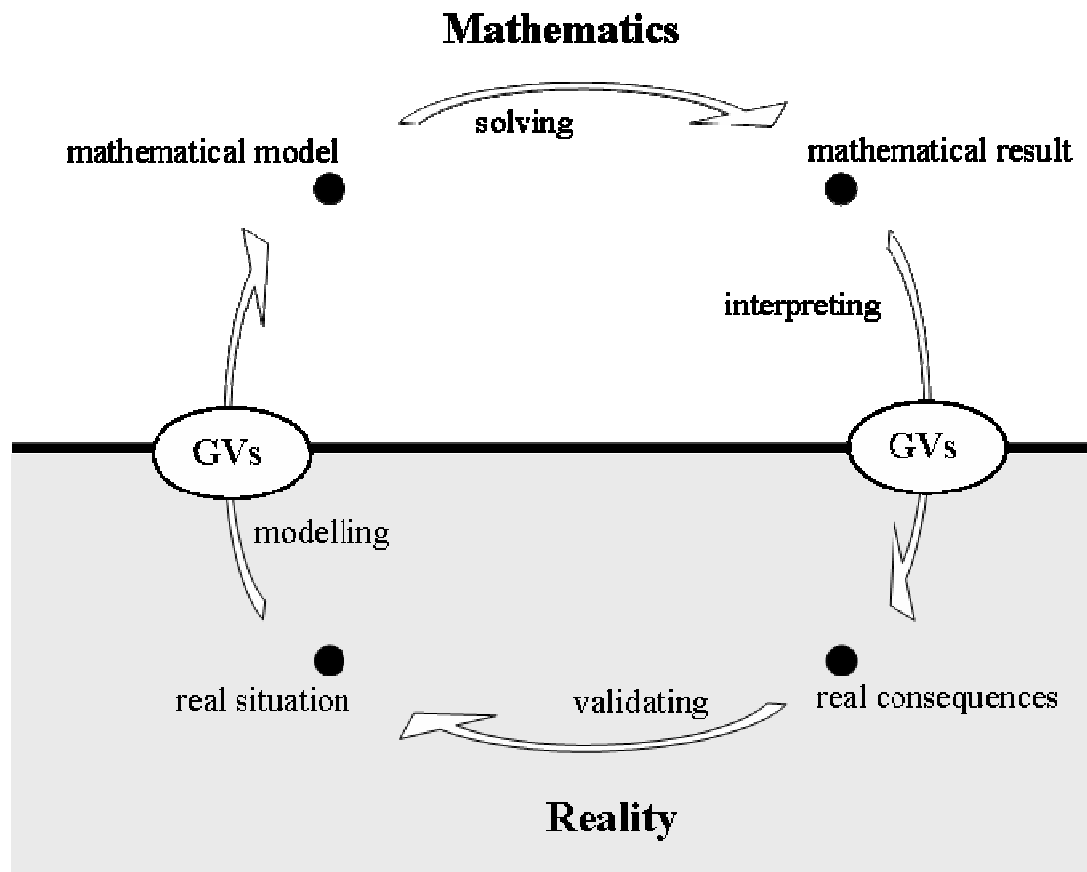

Figure 2: Modelling Process

For our long term study we designed test instruments which are conceptually based on the idea of mathematical modelling and the involved activation of GVs. To get insights into the development of the modelling competency of students, we constructed series of items which progressively require modelling activities concerning the topics of arithmetic, algebra, elementary functions and geometry. In addition to this, we also included series of items which can be solved by mere formula calculating without any GVs and without any thinking about the meaning of the involved concepts or procedures (“technical items” in the sense of Neubrand et. al. 2001).

Two examples, one of each kind:

(1) Kevin wants to buy new sport shoes for 80 €. He has already saved $\frac{3}{10}$ of the price. How much more money does he still need to buy the shoes?

(2) Calculate: $\frac{1}{3} \cdot \left(\frac{1}{2} - \frac{2}{5} \right)$

In example (1) GVs of subtraction (most likely supplementing) and fractional numbers (as operator) are needed. In example (2), however, mere algorithmic knowledge of multiplying and subtracting of fractions is sufficient.

We are convinced that serious problems of mathematical achievement development are caused by an insufficient growth of modelling competency and corresponding GVs during secondary school. We furthermore assume that many students turn too frequently to formula calculating which is one of the reasons for difficulties with applied mathematical problems.

Methodological Considerations and First Results

To provide detailed development data, test instruments are necessary which are able to assess mathematical achievement development (1) with respect to different levels of mathematical competence and (2) in different subgroups. Furthermore the test should (3) include the main mathematical topics over grades 5 – 10.

For this purpose we constructed a scalable test instrument, referring to the dichotomous Rasch model (Embretson and Reise, 2000), which operates on three levels:

- Level 1: A master score (based on the whole item system) documents the global mathematical achievement.
- Level 2: Subscales (based on item groups) are used to describe the development in different topics and levels of competence.
- Level 3: Detailed item analyses give insights into the development of specific abilities including the relevant GVs.

To include the main mathematical topics of grades 5 – 10, a developed grade-specific instrument is used (vom Hofe et al., 2002), consisting of grade specific subtests which altogether form the main test. Basis of the test design is Multi-Matrix-Sampling with anchor-items. Altogether a pool of 105 items, tested in various field studies, is used.

The multi-matrix-sampling used corresponds to the prerequisites of the dichotomous Rasch model which allows the measurement of achievement within and between the grades. Following the Rasch model, there is one parameter for each item and there are grade-specific parameters for each student. These parameters of ability are a

characteristic feature of assessing achievement: they characterise the level of mathematical literacy at each grade (for details see Kleine, 2004).

Our test instruments have been evaluated during a period of two years in two field studies ($N_1 = 720$; $N_2 = 1683$). Up to now (January 2004), we have data from the first two waves at our disposal, so we can only give an example of the development analysis concerning grades 5 and 6. To illustrate the different measuring levels of our test instruments we first give some data concerning the general achievement development regarding different school forms and then refer to sub-scale data concerning the development of modelling competency vs. calculating competency.

On the global achievement level referring to the total sample we recognise after standardisation a significant middle increase of more than half a standard deviation in general ($\Delta \bar{\theta} = 58.9$, $t(1817) = -38.46$, $p < .001$) (norm of the sample: $\bar{\theta} = 1000$, $\sigma = 100$). To inspect the development in the different German school forms Gymnasium (High Track), Realschule (Medium Track), and Hauptschule (Low Track), we observe the expected sequence of the middle abilities between these school forms at both measuring times.

The ability increases around two thirds of a standard deviation at the Gymnasium whereas at the Realschule and the Hauptschule it is only around half a standard deviation.

Let us now have a look at the sub-scale data concerning modelling competency vs. calculating competency: Figure 3a shows that we have an increasing development in both kinds of competence from grade 5 to 6 regarding to the subgroup 'Gymnasium total', but we also see that calculating competency increases substantially more than modelling competency ($\Delta \bar{\theta}_{\text{calculus}} = 74.6$; $t(720) = -22.038$, $p < .001$; $\Delta \bar{\theta}_{\text{modelling}} = 18.9$; $t(720) = -5.121$, $p < .001$). This result is in harmony with our hypothesis that conceptual thinking is replaced increasingly by algorithmic rule application during secondary school.

If we now look at specific Gymnasium classes we can identify class effects which can be illustrated in specific development patterns. A typical pattern which can be assumed as extremely problematical is shown in figure 3b: in the Gymnasium Class 012 the calculating competency increases significantly while the modelling competency decreases ($\Delta \bar{\theta}_{\text{modelling}} = 5.40$, $t(13) = 0.188$, n.s.). Even more extreme patterns indicating a drifting apart of modelling and calculating competency can be found when analysing the development of specific students. Concerning the different class patterns, effects of different teaching and learning methods are obvious. Currently we are analysing the correlations between these class effects and other variables of the learning environment.

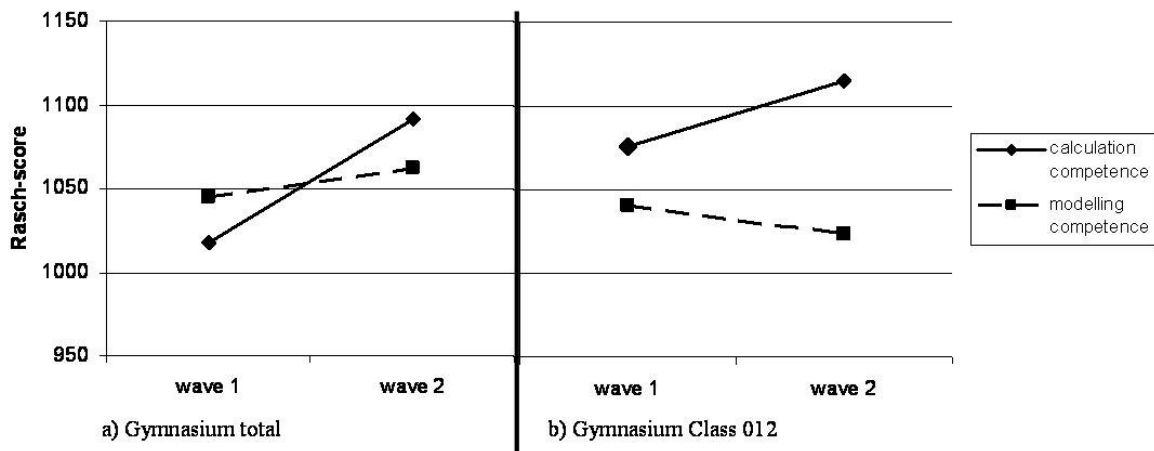

Figure 3: Development of competency in modelling and in calculation
 a) Gymnasium total b) Gymnasium Class 012

(Norm of the sample: $\bar{\theta} = 1000, \sigma = 100$; wave 1: grade 5, wave 2: grade 6)

To take a deeper look at the deficits of this modelling competency stated in the quantitative approach more concretely, additional interviews were carried out on a subgroup of students ($N=36$) with selected items of the quantitative test. The conceptual focus of these interviews was laid on fractions and proportions which is the main theme of mathematical education at grade 6 in Germany and which represents a main topic of the quantitative test. These qualitative studies explore in detail which kind of misconceptions correspond to the deficits. The results show that a major reason for the insufficiency in modelling activities concerning fractions and proportions can be seen in inadequately developed GVs. A typical kind of mistake is the wrong transfer of intuitive assumptions from the natural to the fractional numbers, e.g.:

- The concept that the result of multiplying fractional numbers is always bigger than the factors.
- The assumption that every fractional number has a well-defined smaller and a bigger neighbour with no number in between.

On the basis of the data currently available we have strong evidence that the insufficient increasing of modelling competency is caused to a large extent by deficits in the generation of GVs concerning the new mathematical topics in grade 6, especially fractions and proportions (vom Hofe and Wartha, in press).

Outlook

The results shown above have to be replicated longitudinally in order to learn more about true cause-effect relationships. It is an open question whether the problematical developments of grade 5 and 6 will continue to cause a rising gap between modelling and calculating competency in specific classes. We expect effects, particularly those concerning teaching processes, to cumulate over the years.

We expect our work to lead to different perspectives concerning learning and teaching mathematics at school: (1) For the development of standards and curricula, we hope to provide the empirical background for questions of structure and the cross-linking of mathematical topics. (2) The results of mathematical competency in fractions and proportions on the class- and individual-level show the necessity of new ways of teaching and learning on the basis of a GV-grounded access. Currently we are constructing material for teachers and students for this purpose. (3) Especially teachers need more diagnostic competence to promote the development of GVs and to thwart misconceptions which constrain the further progress in applied mathematics. On the base of our data we are developing special modules for teacher education which can support competence in analysing students' strategies and mistakes.

Our ultimate goal is to give tangible recommendations for the development of mathematics curricula and for the improvement of the instructional, motivational and emotional conditions of mathematical learning environments.

References

- Blum, W.: 1998, 'On the Role of 'Grundvorstellungen' for reality-related Proofs – Examples and Reflections', in P. Galbraith, W. Blum, G. Booker and I. D. Huntley (eds.), *Mathematical Modelling – Teaching and Assessment in a Technology-Rich World*, Horwood, Chichester, pp. 63 – 74.
- Blum, W.: 2002, 'ICMI Study 14 on Applications and Modelling in Mathematics education – Discussion Document', *Educational Studies in Mathematics* 51, 149 – 171.
- Embretson, S. E. and Reise, S. P.: 2000, *Item Response Theory for Psychologists*, Erlbaum, Mahwah.
- Fischbein, Efraim [1987]: *Intuition in Science and Mathematics: An Educational Approach*. Dordrecht: D. Reidel
- Fischbein, Efraim [1989]: *Tacit Models and Mathematik Reasoning*. In: *For the Learning of Mathematics* 9, 9 - 14
- Freudenthal, H.: 1983, *Didactical Phenomenology of Mathematical Structures*, Reidel, Dordrecht.

- vom Hofe, R.: 1998, 'On the Generation of Basic Ideas and Individual Images: Normative, Descriptive and Constructive Aspects', in J. Kilpatrick and A. Sierpinska (eds.), *Mathematics Education as a Research Domain: A Search for Identity*, Kluwer Academic Publishers, Dordrecht, pp. 317 – 331.
- vom Hofe, R., Pekrun, R., Kleine M. and Götz, T.: 2002, 'Projekt zur Analyse der Leistungsentwicklung in Mathematik (PAMLA). Konstruktion des Regensburger Mathematikleistungstest für 5.-10. Klassen' [Project for the Analysis of Learning and Achievement in Mathematics. Construction of the Regensburg Mathematics Achievement Test for Grades 5 to 10], *Zeitschrift für Pädagogik* 45, 83 – 100.
- Kleine, M.: 2004, *Quantitative Erfassung von mathematischen Leistungsverläufen in der Sekundarstufe I. [Quantitative Measurement of Mathematical Achievement in Long-Term-Studies]*, Franzbecker, Hildesheim.
- Neubrand, M., Biehler, R., Blum, W., Cohors-Fresenborg, E., Flade, L., Knoche, N., Lind, D., Löding, W., Möller, G. and Wynands, A.: 2001, 'Grundlagen der Ergänzung des internationalen PISA-Mathematiktests in der deutschen Zusatzerhebung' [Foundations of the Supplement of the International PISA Mathematics Test in the German National Study], *Zentralblatt für Didaktik der Mathematik* 33 (2), 45 – 49.
- Noss, Richard [1994]: Structure or ideology in the mathematics curriculum. In: For the Learning of Mathematics 14(1), 2 - 10.
- Organisation for Economic Co-operation and Development (OECD): 1999, *Measuring Student Knowledge and Skills. A new Framework for Assessment*, OECD, Paris.
- Pekrun, R., Goetz, T. Titz, W. and Perry, R.: 2002, 'Academic Emotions in Students' self-regulated Learning and Achievement: a Program of qualitative and quantitative Research', *Educational Psychologist*, 37 (2), 91-105.
- Usiskin, Z. [1991]: Building Mathematics Curricula with Applications and Modeling. In: Niss/Blum/Huntley (Eds.) [1991]: *Mathematical Modeling and Applications*; Chichester: Horwood, 30 - 45

Contact

Rudolf vom Hofe <vom.hofe@mathematik.uni-regensburg.de>

Michael Kleine <michael.kleine@mathematik.uni-regensburg.de>

Werner Blum <blum@mathematik.uni-kassel.de>

Reinhard Pekrun <pekrun@mip.paed.uni-muenchen.de>

A DYSLEXIC CHILD'S STRATEGIES AND IMAGES IN ARITHMETIC: A LONGITUDINAL STUDY

Xenia Xistouri, *University of Cyprus, Cyprus*

Demetra Pitta-Pantazi, *University of Cyprus, Cyprus*

Abstract: *This paper aims to investigate the strategies and images of a dyslexic child in arithmetic, and how these change from the age of seven to ten. The study focused on the child's strategies and images while dealing with simple arithmetical tasks of addition and subtraction. The results suggest that as the child grew older he moved from counting procedures which were supported by the use of physical or imaginistic counting objects to a more abstract way of thinking. However, as sums became more difficult the child disregarded the more relational characteristics of the numbers and fell back to his physical and imaginistic counting procedures.*

Keywords: arithmetic, images, representations, dyslexia

INTRODUCTION

This paper aims to investigate the development of the strategies and images of a dyslexic child when dealing with verbally posed simple arithmetical tasks of addition and subtraction, at two different ages.

According to the British Dyslexia Association (B.D.A.) (2004), dyslexic children often face difficulties when dealing with simple arithmetic. Many researchers have studied dyslexic children's strategies and difficulties in arithmetic across elementary education (Geary, Hamson & Hoard, 2000; Jordan & Hanich, 2003). Recently, a connection between dyslexic children's arithmetical strategies and their images was suggested (Xistouri & Pitta-Pantazi, 2003). However, until now, no piece of research has studied a dyslexic child's development of arithmetical strategies and images in mental arithmetic. This paper argues that the images and strategies a dyslexic child projects at different grades of elementary education are qualitatively similar. However, these strategies and images do not facilitate his understanding in arithmetic.

DYSLEXIA AND ARITHMETICAL UNDERSTANDING

Dyslexia is a person's inability to comprehend symbolic material (Stasinou, 1999), which may be observed in many aspects of a person's life, including mastering and using numerical notation. The most common characteristics of dyslexics in mathematics are: 1) slowness in calculations, 2) tendency to rely on finger counting, 3) confusion when counting back, 4) difficulty in mental calculations, written algorithms and direction while executing calculations, 5) difficulty in memorising procedures, and 6) tendency to reverse symbols for example 21 seen as 12 (B.D.A., 2004). It should be noted that not all these characteristics appear in all dyslexics or at

the same extent. Dyslexics do not comprise a uniform group, but different people can have different combinations of these characteristics (Miles & Miles, 1993).

Due to their difficulties in mathematics, dyslexics develop strategies in order to overcome their obstacles, which arise from slow memory-recall (B.D.A., 2004). The most common strategies amongst dyslexic children are counting strategies. According to Garnett (1992) and Geary (1993), dyslexic children tend to over-rely on counting strategies and commit more errors than their peers. The strategies of automatic retrieval and derived fact are less often encountered amongst dyslexics.

Recent longitudinal studies by Geary et al. (2000) and Jordan and Hanich (2003) suggest that children with both reading and mathematical disabilities (MD/RD) – such as dyslexia – performed lower than their average normal peers. Geary et al. found that children with MD/RD reduced their procedural and retrieval errors from grade 1 to grade 2. However, both studies seem to converge to the fact that retrieval deficits remain a strong characteristic in these children's achievement. Thus, fact retrieval remains their less-frequently used strategy.

ARITHMETICAL UNDERSTANDING AND IMAGES

A considerable body of research in psychology and mathematics education suggests that human beings vary in their cognitive style and in their approach to information processing. In 1976, Skemp made a first distinction between two different kinds of understanding: instrumental and conceptual. Hiebert and Lefevre (1986) made another distinction between procedural thinkers, those that prefer to follow a series of steps, a procedure, and conceptual thinkers, those that have a wider concept network, where different objects and procedures are related. Later on, Gray and Tall (1994) made a distinction between procedural and proceptual thinkers and compared their arithmetical understanding. Procedural thinkers are the ones that depend mainly on the use of procedures and proceptual thinkers are the ones that have the flexibility to view an arithmetical symbol either as a procedure or as a concept. According to Gray and Tall, low achievers seem to be trapped in a procedural way of thinking whereas those that succeed in mathematics have a proceptual way of thinking. Low achievers tend to depend on counting procedures such as count on or count back in order to answer a question. On the contrary, high achievers rely much less on procedures and they tend to retrieve known facts or derive new knowledge from what they already know. Gray and Tall hypothesized that this qualitative difference in children's way of thinking arises from the different interpretation children give to arithmetical symbol.

Pitta and Gray (1997) went a step further, by studying the different mental representations children project in arithmetic. They have studied children at the extremes of mathematical achievement, while dealing with mental arithmetic. Pitta and Gray described that high achievers tended to retrieve answers from memory and when visual images were present they appeared mainly as “flashing symbols” that acted as memory reminders. On the contrary, low achievers focused on physical or mental counting objects and executed counting procedures.

Nevertheless, it has been argued that children's internal systems of representation of numbers go through a series of changes: from semiotic to autonomous (Thomas, Mulligan & Goldin, 1996). However, Pirie and Kieran (1994) indicated that a child's powerful early attachments to particular dominant images can seriously influence the development of understanding. What happens in the case of a dyslexic child? Do a dyslexic child's images in arithmetic change over time? And if so, what are the consequences for his or her understanding in arithmetic.

METHODOLOGY

For the purposes of the current study, a dyslexic boy, Aaron (pseudonym), was interviewed at the ages of seven (2001) and ten years (2004). Aaron had been diagnosed by both a private and a public educational psychologist as dyslexic. The private educational psychologist, who had examined Aaron at the age of seven, had performed the WISC-III test, according to which Aarons' IQ score is 90 with a Full Scale score of 87 and is considered Average. His verbal IQ score of 95 with a Scaled score of 46 is also at the Average level, while his Performance IQ score of 86 with a Scaled score of 41 is at the Low Average level. The public educational psychologist's tests and measures were school-confidential and were not acknowledged to the parents, they did confirm however that the child suffered from dyslexia.

Ever since Aaron started second grade he had been getting support for his mathematics and Greek language by a public special educator. These support lessons were daily and were taking place during school-time. Their duration was 40 minutes. During an interview Aaron's special educator described that, in her teaching, she emphasized the discovery of different procedures in arithmetic and that she indirectly proposed derived knowledge, instead of the memorisation of number facts.

Two clinical interviews were performed. Each focused upon the strategies and images Aaron projected when responding to a graded series of elementary, context free arithmetical problems of addition and subtraction. The problems were subdivided into three sub-groups: Additions and subtractions up to 10, up to 20, and over 20 and with two-digit numbers. Aaron was presented with an arithmetical task verbally and he was first asked to give an answer and later to describe what was happening in his head as he was mentally trying to reach his answer. The classification of strategies used in this study followed a combination of the ones given by Pitta and Gray (1997), Geary (1993), and Garnett (1992) in arithmetical situations. The categories were (a) retrieval from memory (known facts), (b) counting strategy and (c) derived fact. More specifically, a response was classified as retrieved from memory when the child claimed that he knew it or just came to him and the response was given in less than three seconds. A counting strategy was recorded each time the child claimed he had counted in order to reach the answer or the interviewer had observed the implicit or explicit use of a counting procedure. The answer was classified as a derived fact when the child claimed he had based his solution on other known facts, for example "2+3 is 5, because I know 2+2 is 4 and plus 1 is five". The kinds of images used in order to obtain the solution to any problem were classified as either physical or

imaginistic. They were physical when the interviewer observed the use of physical counters, such as fingers or other objects. Images were recorded each time the child claimed he had seen something in his mind which aided him to find the solution.

RESULTS

Aaron's strategies and images at the age of seven

When Aaron was interviewed at the age of seven, it was obvious that he was facing some serious difficulties arising from his relative slowness in simple calculations. This was mainly due to the procedures he used to answer the questions. Although most of the answers he gave to the easiest group of sums (up to 10) were correct, he seemed to over-rely on counting procedures. He solved 11 out of 15 using counting procedure, two of them with the use of a memory rule and only two as known facts. It is important to show the four calculations Aaron was able to solve without counting: $4+4=$, $0+2=$, $_+5=5$, $6-0=$. Note that no counting is required for the last three sums, the latter of which were solved by using a memory rule relevant to zero.

When dealing with additions and subtractions to 10, Aaron relied greatly on the dots and numbers he saw in his mind. He described a number of different visual images he used while counting. One of his images is what he called "dots". According to Aaron, while solving the sum $2+1=$, he described that:



Figure 1: Image of addition with dots

There are two dots. And another one comes down hanging by a rope. And they come down one by one. Boing boing! (2+1)

As he later explained, he first saw the larger addend in a row of dots. Then a number of dots, representing the smaller addend, came down one by one with a rope. Each time a dot came down, Aaron added up one to the larger addend. Aaron's diagram describing his strategy and image for $3+1$ is shown in Fig.1.

A variation of the dots image was used in subtractions up to 10. The difference was that the dots did not come down by rope, but were crossed out with Xs (see Figure 2):



Figure 2: Subtraction with mental dots

I had three dots and I crossed them out with Xs and finally there was only one left. (3-2)

Number line was another image described by Aaron (Fig.3). He said that he saw all numbers together and made steps backwards. This kind of image appeared only when he was dealing with subtractions.

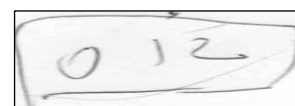

Figure 3: Image of number line

His image of a number line was modified when he had to do " $9-_ =1$ ":

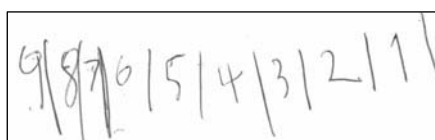

Figure 4: Aaron's image of number line (2)

I went steps back and I saw numbers. 9 and then it went... and then was 8, a line, then 7, then 6, a line... I saw them one by one, so I don't make any mistakes,

and jump from 4 to 2. Here the numbers are like in boxes and I see the boxes one by one. (9-_=1)

Note that the direction of this number line is from left to right, while in its usual form and in Aaron's previous example, the direction was from right to left. This may be evidence of the visual-spatial flexibility of dyslexic students which is documented by a number of researchers (Garnett, 1992) or evidence of dyslexic children's tendency to mentally reverse symbols and icons.

During the interviews it became apparent that Aaron had to put some effort in order to select the image that was most appropriate for each question. This is what he said:

8; Wait, let me think...7. I went backwards again. First I tried dots, but I couldn't do it. Then I found an easier way to go backwards, until I reached one. I saw numbers! (9-_=1)

Moving on to additions and subtractions up to 20, Aaron started relying exclusively on finger counting. He admitted that counting dots and seeing numbers was too difficult for these numbers. So, he counted his fingers, first in a discreet way (that is trying to hide his hands under the table or behind his back) and later by putting his fingers in front of him. He was unable to reach a correct solution to 6 out of the 20 cases. In two of these instances, Aaron seemed to have been confused in regard to the direction he had to count. This could be evidence of directional difficulty which is considered as symptom of dyslexia (Stasinos, 1992; Gagatsis, 1997; Gagatsis, 1999):

I need my fingers for this one. 15 minus 4... It's 19. (15-4)

15 minus... I need my hands again... It's 24! (15-9)

In all the subtractions, Aaron started from the smaller number and counted on to the larger number to reach the answer. This "recipe", which resembles Hiebert's and Lefevre's (1986) procedural thinking, seemed convenient, until Aaron reached a subtraction where the minuend was missing.

It's 4. I went 8, 9, 10, 11, 12. (_-8=12)

There were also some indications that the counting procedure was leading him to some errors. For example in 16-3:

It's 12. I went 15, 13, 12. (16-3=)

In the cases of sums over 20, Aaron followed the same strategy as with the sums up to 20, counting. In all four two-digit sums, Aaron failed to give any correct answers. He did attempt to answer these questions by counting either with dots or fingers, but his strategy failed.

Aaron's strategies and images at the age of ten

When Aaron was interviewed at the age of ten, he seemed more confident and able to answer more questions immediately. Especially in the first group of sums up to 10, he answered nine out of the 15 sums by retrieving the answer from memory. It is

important, though, to report the sums Aaron responded to immediately. These were $2+1$, $3-2$, $5-4$, $0+2$, $_{-}+5=5$, $6-0$, $3-3$, $4+4$, $8+2$. Notice that the first three sums concern successive numbers and can be solved with the mere recall of the number sequence. The next four sums can be solved without counting, the latter of which can be solved with the use of a memory rule. The sum $4+4$ is considered by Garnett (1992) as one of the easiest sums since only two numbers (instead of three) need to be recalled, the addend and the sum. Finally, the last one is a pair that adds up to 10. Teachers in Cyprus put a lot of emphasis on this type of sums.

When Aaron couldn't retrieve the answer to a sum up to 10, he relied on counting procedures. These counting procedures were supported by images that represented mental counters. The first type of counters Aaron described was the "little lines" along with the numbers he sees in his mind. According to Aaron, when he solved $3+5$, he saw the operation in his mind, and completed it by counting the little lines which appeared below the numbers.

*I saw three little lines... And five little lines under 5... equals 8.
So I said 1, 2, 3, 4, 5, 6, 7, 8.*

(3+5)

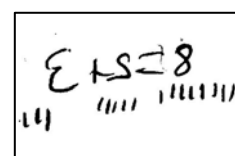

Figure 5: Aaron's representation of lines

Note that the symbol 3 in Figure 5 is mirrored. This is an example of dyslexics' tendency to reverse and mirror symbols. (B.D.A., 2004).

As soon as Aaron responded to this question, he claimed that another kind of image came to his mind. He argued that, since he wanted to be really sure about his answer, he had to check it once more by using another "way": the "fingers in his mind" (Figure 6).

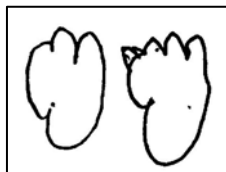

Figure 6: Aaron's mental fingers

I forgot all about these (the mental lines) and then I saw three fingers. Three fingers and five fingers and I did it. It was 8, but I didn't see eight fingers, I saw the number 8.

(3+5)

When Aaron was asked to explain why he uses both ways and whether they appeared at the same time, he responded:

*Because I could have made a mistake here (the lines) and I did this to be sure.
But very fast! First this one goes (the lines) and the other comes.*

(3+5)

When asked which of the two methods was easier, Aaron chose his mental fingers.

*It's because when I was little, I couldn't find it, so I put up my fingers and got the answer. Now I see them in my mind... I am used to it and I do it to be sure.
Like if I find 8, and then I do this to be sure. I just look at them and I know it's eight!*

(3+5)

What Aaron was essentially doing is a "mental subitizing". This means he was able to determine the number of objects in a group without counting but simply by looking at the group of objects. This is often done when a child puts up his or her fingers to represent the addends of an arithmetical question. The difference here being that the procedure was imaginistic and not physical.

His mental fingers strategy was modified when one of the addends was missing. Aaron described seeing the first addend and the result in mental fingers. Then, he visually recognized the difference and reached the answer.

They showed (the mental fingers) six and nine. And I had to figure out from 6 to 9 how many, and I did. They were split up, one was on this side and the other on the other side, and I had some space in the middle to find it.

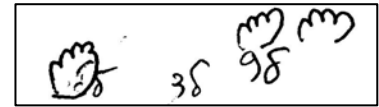

Figure 7: Aaron's addition with mental fingers

$$(6+ _ =9)$$

This strategy of visually comparing and recognizing the difference in the amount was very convenient for Aaron, but it seems that it was once more a well-rehearsed procedure which, however, he did not fully understand. This became apparent when he had to respond to the question $_ -5=2$. The answer he gave was 3:

I just did it with my fingers, nothing else. Like I showed you earlier. I had some space here in the middle and five... I said 2 up to five, and found 3. ($_ -5=2$)

In only one case of sums up to 10, Aaron applied a derived fact strategy. He used the well-known $5+5=10$ sum to derive the answer to $9-5$.

Since $5+5$ is 10, minus 1...I did it fast and then I said, 10 minus 5 is 5. So, 9 minus 5 is 4! ($9-5$)

What was interesting was that Aaron needed to visualize the sum, even if it was a known fact. It is hypothesized that this need is a spontaneous reaction that emerges from his difficulty to retain information in his memory.

I had it written there. 9 minus 5, and I saw it written in the air. I knew the answer, but I still saw it up there. ($9-5$)

I didn't do anything. I went to write... I wrote 3 in my mind, but then it came to me! All of a sudden! ($3-2$)

Moving on to additions and subtractions up to 20, Aaron managed to solve 1 by retrieving the answer directly from his memory, 6 as derived facts and 13 by counting. He claimed that he first tried his mental fingers, but they were inconvenient for such large numbers. Then he suddenly remembered his derived fact strategy, which he applied for several times in a sequence. It is important to note that Aaron applied the derived fact strategy, directly after stating that his teacher did not approve of finger counting.

I got used to doing it with fingers and it helps me more...When I was little, all I knew how to use were my fingers. My teacher, Mrs. M, told me not to use them. I tried and I tried and I could do it for a while. But then I would again use my fingers...Now I see them in my mind. But I prefer to do it with my fingers.

Let us take a look at which sums Aaron managed to solve without counting. The only sum he could retrieve from his memory was $10+2$. Later on, he described the memory rule which helped him retrieve sums which included the number ten.

It is easy because it has 10 in it... When you do 10 and something, for example 10 and three, it's 13 because it goes next to 10.

Aaron sometimes used a derived fact strategy which is based on the knowledge of the sums with the same number. His strategy is described below:

9 plus 8 is 17. Because 9 plus 9 is 18, minus 1 is 17. (9+8)

The first strategy Aaron attempted to apply for sums up to 20 was to count with mental fingers. As he described, he saw the first addend, which was a two-digit number, in symbols and the second addend in mental fingers (Figure 8).

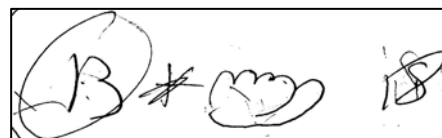

Figure 8: Aaron's addition up to 20 with mental fingers

I saw 13 and then five fingers... 1, 2, 3, 4, 5. And I found 18. (13+5)

As sums got more difficult, Aaron abandoned his derived fact strategy and fell back to his counting strategy. First he tried verbal counting. Then he started using his fingers. In some cases he tried to hide the fact by putting his hands under the table. In some instances, though, it was so difficult for him that he had to put his hands in front of him in order to assure himself that he had the right answer.

7; I went from 8 to 14. I said 8, 9, 10, 11, 12, 13, 14. Is it right? I don't know. I have to think... I'll do it with my fingers. 9, 10, 11, 12, 13, 14. It's 6! (8+_ =14)

In all the subtractions, Aaron used the count-back strategy. He supported his strategy with a mental number line, so that he would not lose track of the numbers counted. It is assumed that a mental image was necessary for him in order to count backwards. What is interesting in Aaron's use of number line is that when he counted back numbers, in order to keep count of how many numbers he had counted, he took them in pairs. Thus halving the numbers he had to remember (Fig. 9).

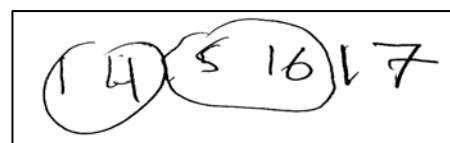

Figure 9: Aaron's mental number line

Aaron managed to solve mentally and correct all two-digit sums, by adding first the tens and then the units.

Summing up, we can see in Table 1 that Aaron's known facts increased from 3 to 10 and his derived facts from 2 to 12. It is hypothesized that this change has contributed to the increase of Aaron's correct responses from 29 to 39. However, it is noteworthy that although his counting strategies had decreased, they still constituted Aaron's most frequently used strategy. This finding is in accord with previous studies by Geary et al. (2000) and Jordan and Hanich (2003).

Table 1: Aaron's strategies and correct responses at age 7 and 10

| (N=42) | Retrieval | Counting | Derived | No response | Correct |
|----------|-----------|----------|---------|-------------|---------|
| 7 years | 3 | 32 | 2 | 5 | 29 |
| 10 years | 10 | 20 | 12 | 0 | 39 |

In Table 2, we can see Aaron's representations at age 7 and 10. His need for physical representations had dropped from 22 to 5. It also appears that at the age of 10, Aaron solved most sums without the use of any physical counters or images. This is mainly due to the fact that a lot of responses are now retrieved automatically from memory.

Table 2: Aaron's representations at age 7 and 10

| (N=42) | Physical | Visual Images | None |
|----------|----------|---------------|------|
| 7 years | 22 | 9 | 11 |
| 10 years | 5 | 11 | 26 |

DISCUSSION AND CONCLUSIONS

At the age of 7, Aaron relied mainly on his counting strategies. He seemed to have the need to translate the numbers of an operation into concrete items, either physical or imaginistic, in order to count them. Such behaviour would fit the profile of a procedural thinker, as described by Gray and Tall (1994). In addition to this, Aaron seemed to have the need to visualize what he was doing and then count it, in order to be confident that he was doing it right. Geary (2000) refers to this tendency of dyslexics as a "rigorous confidence criterion". Similar behaviour was exhibited at the age of ten, although the use of counting procedures was reduced. Despite this reduction, the counting procedure remained his most frequently used strategy. He continued to support his counting with his fingers and a variety of visual images. At the age of ten his use of fingers was significantly reduced whereas the use of images remained almost at the same level. Furthermore, as he grew older he tried to focus on derived facts and avoid using his fingers. Eventually, as he admitted, he did what he felt more comfortable with. It is hypothesized, that the pressure on Aaron not to use his fingers led him to create this plethora of images. It appears to be his attempt to do things in the "head". We do not argue that all dyslexic children project visual images. As we have already stated at the beginning of the study, dyslexic children comprise a heterogenous group of students. Further research with a large group of dyslexic students is needed in order to answer whether dyslexic children have a tendency to create a lot of visual images in arithmetic.

Although Aaron's mistakes in counting were reduced from the age of seven to the age of ten, all of his incorrect responses arose from his counting. It appears that the images that replaced the external fingers did not cause any shift to a qualitative different kind of thinking. Aaron's thinking continued to be in a large extent procedural. It is conjectured that Aaron's increase of known and derived facts is what mainly contributed to the increase of his correct responses. Therefore, it is suggested that teaching arithmetic to dyslexics should not only emphasize the reduction in the use of counters (i.e. fingers), but also on building an understanding of the nature of numbers and their relations, as part of deriving new knowledge.

REFERENCES

- British Dyslexia Association.: 2004, 'Mathematics and dyslexia: A guide for parents and teachers', On-line, Available: <http://www.bda-dyslexia.org.uk/main/information/education/e07maths.asp>.
- Gagatsis, A.: 1999, 'Communicative interaction situations between children with symptoms of dyslexia constructing geometrical figures', *Early Child Development and Care* 151, 29-40.
- Gagatsis, A.: 1997, *Didactics of Mathematics and Dyslexia*, Erasmus, Nicosia.
- Garnett, K.: 1992, 'Developing fluency with basic number facts: Intervention for students with learning disabilities', On-line, Available: http://www.ldonline.org/ld_indepth/math_skills/garnett.html.
- Geary, D. C.: 1993, 'Mathematical disabilities: Cognitive, neuropsychological, and genetic components', *Psychological Bulletin* 114, 345-362.
- Geary, D. C., Hamson, C. O. and Hoard, M. K.: 2000, 'Numerical and arithmetical cognition: A longitudinal study of process and concept deficits in children with learning disability', *Journal of Experimental Child Psychology* 77, 236-263.
- Gray, E. M. and Tall, D. O.: 1994, 'Duality, ambiguity and flexibility: A proceptual view of simple arithmetic' *Journal for Research in Mathematics Education* 25(2), 115-141.
- Hiebert, J. and Lefevre, P.: 1986, 'Conceptual and procedural knowledge in mathematics: An introductory analysis', in J. Hiebert (ed.), *Conceptual and procedural knowledge: The case for mathematics*, Lawrence Erlbaum Associates, Hillsade, NJ, pp. 1-27.
- Jordan. N. C. and Hanich, L. B.: 2003, 'Characteristics of children with moderate mathematics deficiencies: A longitudinal perspective', *Learning Disabilities research and Practice* 18(4), 213-221.
- Miles, T. R. and Miles, E.: 1993, *Dyslexia and mathematics*, Rutledge, London.
- Pirie, S. and Kieran, T.: 1994, 'Growth in mathematical understanding: How can we characterize it and how can we represent it?', *Educational Studies in Mathematics* 26, 165-190.
- Pitta, D. and Gray, E. M.: 1997, 'In the mind: What can imagery tell us about success and failure in arithmetic?', in G. A. Makrides (ed.), *Proceedings of the First Mediterranean Conference on Mathematics*, Nicosia, Cyprus, pp. 29-41.
- Skemp, R. S.: 1976, 'Relational understanding and instrumental understanding', *Mathematics Teaching* 77, 20-26.
- Stasinos, D. P.: 1999, *Dyslexia and school: The experience of a century*, Gutenberg, Athens. (In Greek)

Working Group 1

- Thomas, N., Mulligan, J. and Goldin, G. A.: 1996, 'Children's representations of the counting sequence 1-100. Cognitive structural development', in L. Puig and A. Gutierrez (eds.), *Proceedings of XX International Conference for the Psychology of Mathematics Education*, Vol. IV, Valencia, Spain, pp. 307-315.
- Xistouri, X. and Pitta-Pantazi, D.: 2003, 'Comparing two dyslexic children's strategies and mental representations in elementary arithmetic', in J. Novotna (ed.), *Proceedings of the International Symposium Elementary Maths Teaching*, Prague, Czech Republic, pp. 161-164.