

**WORKING GROUP 12. From a study of teaching practices to issues in teacher education**

	<b>1819</b>
From a study of teaching practices to issues in teacher education	1821
<i>José Carrillo, Leonor Santos, Liz Bills, Alain Marchive</i>	
Teachers' activity in exercises-based lessons. Some case studies	1827
<i>Maha Abboud-Blanchard, Claire Cazes, Fabrice Vandebrouck</i>	
Expressing generality: Focus on teachers' use of algebraic notation	1837
<i>Claire Vaugelade Berg</i>	
Striving to "know what is to be done": The role of the teacher	1847
<i>Laurinda Brown, Alf Coles</i>	
"You don't need a tables book when you have butter beans!" Is there a need for mathematics pedagogy here?	1856
<i>Dolores Corcoran</i>	
Facilitate research activities at the primary level: Intentional communities of practice, teaching practices, exchanges about these practices	1866
<i>Jean-Philippe Georget</i>	
Adapting the hypothetical learning trajectory notion to secondary preservice teacher training	1876
<i>Pedro Gómez, Maria José González, Jose Luis Lupiáñez</i>	
Formative assessment: Tools for transforming school mathematics towards a dialogic practice?	1886
<i>Jeremy Hodgen</i>	
Developing strategies and materials impact on teacher education	1896
<i>Marie Hofmannová, Jarmila Novotná</i>	
Differences and similarities in (qualified) pedagogical reflection	1906
<i>Alena Hošpesová, Marie Tichá, Jana Macháčková</i>	
Pre-service teachers' representations of division of fractions	1916
<i>Mine Isiksal, Erdinc Cakiroglu</i>	
A task aimed at leading teachers to promoting a constructive early algebra approach	1925
<i>Nicolina A. Malara, Giancarlo Navarra</i>	
The professional development of a novice teacher in a collaborative context: An analysis of classroom practice	1935

<i>Maria Cinta Muñoz-Catalán, José Carrillo, Nuria Climent</i>	
From studies of cooperative learning practices towards a model of intervention on mathematics teachers	1945
<i>Angela Pesci</i>	
Teachers' mathematical knowledge and pedagogical practices in the teaching of derivative	1955
<i>Despina Potari, Theodosios Zachariades, Constantinos Christou, George Kyriazis, Demetra Pitta-Pantazi</i>	
Prospective primary teachers' use of mathematics teaching handbooks	1965
<i>Tim Rowland</i>	
The project work and the collaboration on the initial teacher training	1974
<i>Leonor Santos, Alexandra Bento</i>	
Primary teachers' attitudes towards and beliefs about mathematics teaching: the collective culture of one English primary school	1984
<i>Judy Sayers</i>	
The teaching modes: A conceptual framework for teacher education	1994
<i>Rosa Antónia Tomás Ferreira</i>	
The mathematics content knowledge of beginning teachers: The case of Amy	2004
<i>Fay Turner</i>	
Training mathematics teachers in a community of learners (COL)	2014
<i>Nellie C. Verhoef, Cees Terlouw</i>	
Exemplification in the mathematics classroom: What is it like and what does it imply?	2024
<i>Iris Zodik, Orit Zaslavsky</i>	

## **GROUP 12**

### **FROM A STUDY OF TEACHING PRACTICES TO ISSUES IN TEACHER EDUCATION**

#### **INTRODUCTION**

José Carrillo (Spain),  
Leonor Santos (Portugal),  
Liz Bills (United Kingdom),  
Alain Marchive (France)

#### **Organisation**

Group 12 received 28 proposals. Four were rejected or diverted to other groups, one was a poster, and one author could not attend the conference; therefore 22 were accepted both for being presented at the conference and for being published in the proceedings (in case their authors take into account the ideas emerging at the conference and the suggestions by the reviewers). Each paper was reviewed by the one of the leaders and 2 other authors. One paper was rejected to be published in the proceedings at the end of the process, as the reviewers consider its authors did not include the suggestions in the final version.

Thirty six researchers from 16 nationalities took part in the sessions, which were organised on the basis of four topics, within the domain of teacher education and in relation to the title of the group, developed into panels. The dynamic of the sessions was as follows:

- Short presentations (7 minutes each) OR (in Panel III) some corpus of classroom teacher practice observation is shown, and analysed by some of the participants through short presentations (7 minutes each).
- Everyone presents what their paper contributes to the topic of the panel. Everyone shall pose at least 3 questions related to their papers to be dealt with in the working groups and the further discussion.
- Reaction by one participant, posing some questions for the working groups and contributing some ideas from his/her paper in relation to the presented papers (panels I and IV only).

- The whole group splits into several smaller groups. Task for the groups: to approach the questions posed by the presenters taking into account the papers for this panel, those questions related to the topic of the panel being prioritised. One can include some other questions emerging from the presentation.
- The groups report their outcomes to the whole group. Discussion about the topic of the panel on the basis of related questions. Further discussion of the papers on the basis of the other questions.
- Specific reaction by one participant (panels II and IV only).

The organisation of the sessions was highly valued by the participants. However, some suggestions came across: to provide stability in small groups without losing the opportunity to communicate with different people; to search for more tasks to link papers in panels (as in panel III); to have access to the questions posed by the authors at the same time as the papers; to ask authors to choose questions (three was thought to be a good number) which are adequate to research.

## **Panels**

In what follows we set out the emerging issues and ideas around these issues from the four panels.

- **PANEL I: Tasks and resources in pre-service teacher education**

In this panel we discussed a number of learning tools and resources and their implementation in pre-service teacher education. We dealt with the process of such implementation as well as its goals.

### *Emerging issues*

- When handbooks in pre-service teacher education are used in different countries what kind of knowledge (SMK? PCK? Other?) is being acquired?
- What are the particularities and usefulness of the hypothetical learning trajectory in pre-service mathematics secondary teacher education?
- What is the role of algebraic babbling and the sequence of scenes on pupils' activity in pre-service teacher education?
- What can we learn from the experiment of teaching mathematics in a foreign language and its implication for teacher education?
- How can we manage the tension between superficial large-scale dissemination and more meaningful small-scale dissemination of notions like formative assessment and dialogic practice (that come from the research findings)?

*Ideas around the emerging issues*

- The influence of a teacher's professional knowledge in everything he/she perceives in the classroom;
  - the importance of putting mathematics forward when thinking about teacher education, and dealing with the unpacking of mathematical entities;
  - the importance of disseminating research findings in a right way in order for the teachers to have a clear picture of what the researchers are meaning;
  - the challenge to deal with maths and pedagogy in an integrated way (the connections between mathematics and pedagogy should be explicit);
  - the need to re-think both pre- and in-service teacher education in terms of approaching the above mentioned challenges, which affects curriculum, philosophy, design of materials, etc.
- **PANEL II: Approaching reflection in mathematics teachers' professional development**

Each of the six papers included a description and some analysis of an approach to teacher development which involved teachers both in reflection and in collaboration. All of the approaches:

- involved groups of teachers and/or student teachers working together in groups
- sought to promote reflection as a means of professional development
- involved an 'expert' in the form of a teacher educator or researcher.

*Emerging issues*

- Different understandings of reflection were apparent within the different papers and came to light through our discussions. What sense can we make of the different models?
  - Can there be reflection without purpose and without consequence? Is awareness necessary for reflection or is it a consequence of it?
  - Is the notion of reflection culturally specific, so that there are naturally different forms of collaborative reflection in different contexts (e.g. lesson study from the Japanese context)?
- What is the relationship between the work done during the collaborative group meetings and reflection in the school environment?

- What happens when the novice teacher (trained in collaborative work) meets the un-collaborative nature of reality in school?
- Project work is burdensome, how can it be sustained? Effective collaborative work needs institutional support and recognition from all institutions involved.
- What is the role of the ‘expert’ in collaborative groups? Do we (as researchers) know what good teaching is, in every context?
- Artefacts used in collaborative work can form ‘boundary objects’ (Wenger) for communication between different ‘communities of practice’ (e.g. teachers and researchers).

How are such boundary objects most effective? What are the advantages of making boundary objects more or less detailed/complex?

*Ideas around the emerging issues*

- Genuine collaborative work needs an understanding of roles and skills in performing those roles. In particular we should not assume that the skill required to become an ‘expert critical friend’ develops in the didactician without deliberate effort.

- **PANEL III: Models to analyse the practice**

Each of the six papers included models of analysis. In particular, there were considered the knowledge quartet - Rowland, Huckstep & Thwaites, 2004-, Teaching third – analytic third - Ogden, 1994 -, Curricular theme/ Educational orientation - Andrews, 2006 -, and Cole and Engeström’s model - Engeström & al., 1999.

*Emerging issues*

- Even using different models of analysis, all the authors identified the same episode of the video: a certain sentence spoken by the teacher. Is it possible to speak about the existence of a meta-model?
- What are the risks of the approach of “learner taking the lead”? But, who is really leading in classroom? The student, the teacher, the activity?
- Is it necessary to have an ‘expert’ involved in the process of reflection in order that the reflections develop teaching?
- What are the differences between « Activity » and « Practices »? Is the activity situated, whereas the practice is not necessarily bound to a situation? To what extent can we capture practices through a survey of activities?

*Ideas around the emerging issues*

- The analysis of video episodes and their transcriptions are different in terms of outcomes.
- The choice of a framework is not arbitrary: purpose, paradigm...

In relation to these ideas we realised a kind of continuity from conference to conference: some frameworks come again and again.

- **PANEL IV: What about knowledge for teaching (or professional knowledge)?**

Papers in this panel addressed some aspect of knowledge for teaching.

What kind of subject knowledge do teachers need?

How is this knowledge evident in classroom practice (including specifically their choice and use of examples) and how does it influence pedagogic practice?

How does knowledge develop through teacher training programmes and how can our programmes be designed to enhance subject knowledge?

*Emerging issues*

- Is the focus on the choice and use of examples a useful mechanism for working on subject knowledge and pedagogic content knowledge?
- How can we encourage teachers to see the usefulness of frameworks (each one being useful for different purposes) to develop their teaching?
- How can we help pre-service teachers to bridge between theory and practice, or between the university and school context? What is the relationship between mathematics knowledge for teaching which is content-specific and that which is more general? What strategies can we offer teachers to develop their content-specific subject knowledge independently?

*Ideas around the emerging issues*

The practicalities of teacher development on a large scale are complex. Career structures for teachers affect their motivation to take part in professional development (differently in different countries) and relationships between university and school need to be handled carefully. Small scale professional development work with schools tends to deal only with 'special teachers' whereas large scale work runs a risk of producing surface or naïve interpretations of 'reform' messages.

### **Emerging issues**

In the discussions in the whole group and in the smaller groups some issues arose, which the participants considered relevant for the present and future work of the group. They constitute some kind of common denominator of all the panels. The three first issues emerged at CERME4 too, and all of them represent a challenge for us:

- Discussion on theories, perspectives and methods to approach the flavour of classroom activity
- Notion of community of practice and related notions
- Confrontations of frameworks and models by means of analysing some corpus of a classroom teacher practice observation
- The nature and conditions of collaborative work. Particularly the role of the experts, and the necessity of making it possible that teachers meet together in order to reflect on their practices.
- Different notions about reflection



## **TEACHERS' ACTIVITY IN EXERCISES-BASED LESSONS SOME CASE STUDIES**

Maha Abboud-Blanchard, Claire Cazes, Fabrice Vandebrouck

Didirem, Research team in the didactics of mathematics, University Paris 7, France

*This paper focuses on teachers' activity during ICT lessons. The theoretical framework used is activity theory, particularly Engeström's model which takes into account different components of the teaching's context. We used this model to analyse some case studies that stem from a corpus of classroom teacher practice observations. Results show how teachers cope with the introduction of an ICT tool in their classroom. Few adaptations and professional evolutions are exhibited; they often come from internal negotiations between personal opinions and community pressure. Finally, we discuss briefly how these results could help to investigate the issue of ICT teachers' education.*

In 2003, a regional French project focused on the use of ICT (Information and Communication Technologies) at high school level. The project aimed to encourage voluntary teachers to use on-line resources. The specific tools, called here E-Exercises-bases (EEBs), are software applications that mainly consist of classified exercises with an associated environment, which can include advices, corrections, explanations, tools for the resolution of the exercises, scores and sometimes, even corresponding courses, etc. They differ from microworlds or computer algebra systems (CAS) which are open environments in which generally no specific tasks are predefined. The aims of the regional project were pragmatic: as EEbs exist, it was necessary to observe the potentialities of such tools in ordinary classes. General questions were: how do teachers use them? What information or training could help teachers to improve their use of them? How do students work with such tools? What type of mathematic is it possible to do with them? Our team was asked to support the teachers and to observe the effect in the teaching-learning process. The duration of this project was 3 years and it concerned 10-th grade classes (Artigue, 2006). Nearly 50 teachers were involved in this project.

In this paper, we focus on the part of our research concerning the teachers' practices. Studies about teachers' using technologies in mathematics classes are relatively recent phenomena. Some of the studies show that teachers do not significantly change their practices in order to take advantage of the potentialities of ICT; they rather try to solve problems related to their actual practices (Ruthven & Hennessy, 2002). Others studies attempt to investigate beyond the classroom and to track different factors influencing teachers' practices (Monaghan, 2004). This is also our aim. We assume that the observation of teachers involved in the regional project may provide interesting elements for two reasons:

- Due to the introduction of an EEB in their classrooms, they have to change, partly, their practices. We think that this is an "optimal moment" to observe practices.
- They have great latitude to operate this shift because there are no major constraints in using an EEB (for instance, it is not compulsory to use a specific scenario; teachers are free to choose exercises and to build their own on-line worksheets for their students).

We first present the theoretical model chosen and the methodology in order to report on the reality observed. Then we specify the data collected and some results referring to three case studies. The last section provides a discussion.

## **THE THEORETICAL FRAME TO REPORT ON TEACHERS' ACTIVITY**

As our interrogation concerns teachers' practices using an ICT tool to teach mathematic to a group of students, we refer to the activity theory, which provides a way to study both the use of an artifact and the individual, as well as the social level interlinked phenomena. Due to the didactic approach, we also need elements to describe the tasks proposed to students and also the teachers' interventions during the lessons.

### **Activity theory**

Activity theory was developed in the Soviet Union. The philosophical underpinnings of this theory include the ideas of Hegel and Kant, as well as the theory of dialectical materialism developed by Marx and Engels. For Marx and Engels, labour is the basic form of human activity. Their analysis stresses that in carrying out labour activity, humans do not simply transform nature: they themselves are also transformed in the process. The activity theory evolved through the work of Vygotsky as he formulated a new method of studying thought and consciousness. He was very sensitive to "the similarity between Marx's notion of how the tool or instrument mediates over human labour activity and the semiotic notion of how sign systems mediate human social processes and thinking. In both cases, the point is that instruments are not only used by humans to change the world but also to transform and regulate humans in this process" [Wertsch, 1981]. Vygotsky's idea of artifact-mediated and object-oriented action was reformulated by the now famous triangle: Subject, Object, Mediating artifact. An activity is composed of a subject and an object, mediated by a tool. A subject is a person or a group engaged in an activity. An object (in the sense of "objective") is held by the subject and motivates activity, giving it a specific direction. The mediation can occur through the use of many different types of tools, material tools as well as mental tools, including culture, ways of thinking and language. So, in Vygotsky's early work, the unit of analysis was object-oriented action mediated by cultural tools and signs. There was no recognition of the part played by other human beings and social relations in the triangular model of action. A. N. Leontiev extended the theory by adding several features based on the need to

separate individual action from collective activity. The distinction between activity, action and operation was added to delineate an individual's behaviour from the collective activity system. As a result of the need to consider the shared meaning of activity, the initial theory was reconfigured by the addition of rules, community and the division of labour and was renamed the activity system. An activity system is a way of visualizing the total configuration of an activity as follows:

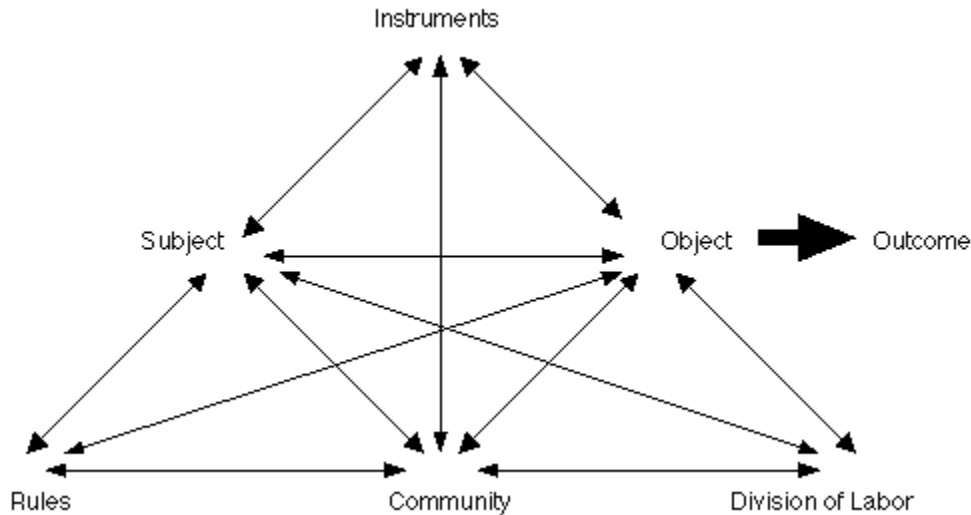

This model is often called the Engeström's model. In this model, the subject refers to the individual or group whose point of view is taken in the analysis of the activity. The object (or objective) is the target of the activity within the system. Instruments refer to internal or external mediating artifacts which help to achieve the outcomes of the activity. The community is composed of one or several people who share the objective with the subject. Rules regulate actions and interactions within the activity system. The division of labour discusses how tasks are divided horizontally between community members as well as referring to any vertical division of power and status.

A great part of the researcher's community uses this model in innovation and organisation of research works [Engeström, 1999], such as in the design of ICT tools to help teaching mathematics, or by exploring the aspects linked to the community of practice [Jaworski and Goodchild, 2006].

### **Our theory's reading**

In this study, the subject is teachers using an ICT tool in their classroom. The object is the mathematical work of the whole class or of individual students. The outcomes are both linked to the students learning and to the teachers' professional evolution during the process. Indeed, teachers try to train students to be 'good mathematicians' and at the same time improve themselves. The instruments of mediation are language, communication and teaching materials. In this study we are especially concerned with ICT tools. The rules are linked to the institution; they comprise curriculum and, for instance, an obligation to teach in a classroom for a one hour lesson. The Community

is composed of colleagues. We do not refer to any division of labour; in our context, this may be concerned with the high school administration, or even with the parents.

The aim of this paper is to explore the dynamic of this model as applied to ICT lessons and to investigate the outcomes; especially aspects that can contribute to the teachers' professional development in order to improve teacher education. Now we have to specify didactic characterisations and the links with this model.

### **Elements to characterize the mathematical tasks**

In this first approach, we analyse the tasks chosen by the teacher on the EEB. We introduce the level of use for the knowledge needed to accomplish the task. The most elementary level of use corresponds to a direct application of the knowledge, in an isolated task. Other levels occur when there is a need for adaptations of the knowledge. Many kinds of adaptations can intervene such as necessity to mix several ideas, to find an appropriate method, to develop several steps in the solving process, to establish relations...The corresponding tasks are called "complex tasks" This distinction between "direct applications" and "complex tasks" is highlighted because of the impact on the quality of the students' learning. Direct applications are necessary, but insufficient to provoke the conceptualisations and elaboration of connections that constitute a central part of the learning process. According to Robert and Rogalski (2005), this analysis of the tasks chosen by the teacher can be linked to a cognitive-epistemological dimension of the teacher's activity. As we shall see later, it may specify the links subject/object; subject/instrument and subject/community

### **Elements to characterize teachers' interventions**

During lessons, most of the interactions between teachers and students consist in oral interventions. We need to characterize these interventions in term of didactic intentions. In order to provide an analytical tool to capture essential elements of the complexity of observed teaching, we refer to the teaching triad defined by Jaworski (2002). Taking into account the specificity of the observed lessons (training exercises with an ICT tool), we define a typology of 3 categories: "mathematical help" (MH) which concerns interventions linked to mathematical helps for students (including validation), "management of learning" (ML) as in the Jaworski triad and "instrumental explanations" (IE) which concerns the explanations of how to use the EEB. Among (MH)s, we distinguish control interventions, local helps which provide sufficient information so that the student can execute the exercise in progress and global helps which help the student to understand more than the simple knowledge connected to the exercise in progress. We emphasize that local helps can simplify the a-priori tasks given to students whereas global helps, especially after students' activity, can enable the student to achieve the desired knowledge. We assume that this typology can help to better describe the teachers' activity and to exhibit some of the teachers' professional evolutions.

## **THE CONTEXT OF THE RESEARCH**

### **The specific ICT involved**

As stated previously, teachers were requested to use an EEB and they may have chosen their preferred EEB from a panel of five such resources. There exists a lot of EEBs. They differ by their content and design. For an example of EEBs, see Wims (<http://wims.auto.u-psud.fr>), a collaborative software available in six languages. It includes exercises for all levels: from primary to tertiary education. Teachers can choose some of these exercises and design their own on-line worksheets for their students. Students can do the same exercise several times in order to improve their marks. In such a case, the structure of the exercise remains the same, but its numerical values differ. For an example of utilization of EEBs at tertiary level, see (Cazes, Gueudet, Hersant, Vandebrouck, 2006).

### **Observed lessons**

All the observed lessons are exercises-based lessons and are, in most cases, organized in the common following way. Before the lesson, the teacher builds an on-line worksheet. During the lesson, the teacher helps students individually to solve the exercises. Most of the time, the worksheet is so long that no student can finish it during the sequence.

### **Data collected**

The regional project enabled a lot of data, both quantitative (questionnaires) and qualitative (video and tape record of observed lessons and teachers' interviews) to be collected. In this paper, we extract all the data concerning three teachers and applied the theoretical framework mentioned above to study their activity in the real teaching process and to show some example of professional evolutions.

## **CASE STUDIES**

We chose these three teachers because each of them enables us to illustrate different aspects of teachers' practices and professional evolutions. Referring to the theoretical frame, it is clear that, for all these teachers, rules are linked with the injunction to use an EEB. However, the institution allows some flexibility; as already said, teachers involved in the regional project can choose their preferred ICT tool from a panel and design their own on-line worksheet, as they want. The first case, Maurice's case, reports on the negotiations procedures from this injunction and this flexibility. The second case, Flore's case, using the oral interventions' typology, explores the teacher's activity during the lessons. Finally, in accordance with the theoretical framework "humans do not simply transform nature: they themselves are also transformed in the process", we attempt to track some of the teachers' professional development. The second case (Flore) partly illustrates this point, and the third case (Diane) goes further by showing immediate, middle and long term aspects in the teachers' professional development.

### **Maurice's case, EEB's choice and exercises sheet's design**

Maurice is a teacher who frequently uses ICT tools in his own work. He works in a technical/professional college with students that have 'learning difficulties'. He has chosen the software "Paraschool" because it's the only one, among the panel, that offers exercises for students. This software contains course elements, but the tasks of the exercises are mostly direct applications of knowledge. For example, this software mainly contains Multiple Choice Questionnaire (MCQ) exercises. For the observed lessons, Maurice establishes two on-line worksheets for his students. The first one contains exercises, which are not specifically designed for technical college students. The chosen tasks are direct applications of the notions of proportionality and linear functions. The second on-line worksheet contains a dozen exercises designed for technical college students. These exercises are again direct applications and they are mixed with course elements. Only at the end of the second sheet, are there some mathematical problems: students have to enter numerical values as answers to these problems. Unfortunately, a mathematical help in the software stipulates that students have to compute some "cross products" to find the answers. Due to this hint, the tasks shift from complex to direct application.

How to explain all these choices? In the questionnaire, Maurice insists on the importance of training exercises which can go beyond direct applications of knowledge. He sees the software as a way to offer complex tasks. He speaks about simulations, animations and he wants to motivate students to a 'rich mathematics activity'. Most of the studied software involved in the experiment satisfies the first point, but Paraschool seems powerless in increasing the level of difficulty of the tasks. In addition, Maurice finds that Paraschool could be improved by having real-world situations' exercises. Hence, he is aware that Paraschool contains an explicit level for technical colleges, but that the designed tasks are not relevant for a rich mathematical students' activity. Therefore, other software may better satisfy Maurice's requirements for his students. In addition, Paraschool is not free, but we know that a Paraschool agent had come into the college to present this product to the teachers. These remarks reinforce the idea that Maurice's choices are not necessarily of his own personal thinking. There is certainly an institutional or a community pressure for choosing Paraschool as it is the only software which is explicitly designed for technical colleges.

Maurice also tries to improve his worksheet by introducing some tasks from another level of teaching. He includes some exercises from the non-professional part of the software, but the tasks that he chooses are still mainly relatively simple. In the second on-line worksheet, some complex tasks appear at the end of the sheet. Even if he would like to go beyond direct applications of knowledge, Maurice has to take into consideration that his students are weak. He seizes the opportunity offered by the software to include course elements in the sheet. Even if the observed lessons are training sessions, it is possible for Maurice to help his weak students by repeating the

associated courses via the software. Again, Maurice's choices are guided by the context, especially the object of the activity linked to students in difficulty. It doesn't allow him to go very far in the level of difficulty of the chosen exercises.

### Flore's case, activity during two sessions

Two exercises-based lessons are investigated in Flore's case. The EEB chosen by Flore does not provide a help facility to solve exercises. Here is the classification of Flore's actions during each lesson.

	ML	IE	MH (mathematical helps)		
	Management of learning	Instrumental explanations	Local help	Global help	Control
Session1	54 (51%)	16 (15%)	18 (17%)	12 (11%)	5 (5%)
Session2	12 (12%)	8 (8%)	43 (44%)	34 (35%)	1 (1%)

**Table 1: classification of Flore's actions during each session**

Firstly, this example shows the complexity of the teachers' practices. Secondly it shows the flexibility and the professional evolutions of the teacher, as explained below.

In lesson 1, the first exercise was a 6-th grade one. Students succeed, but are very slow. In the interview, Flore said that they were slower than she anticipated, so she makes them hurry. That explains the large number of (ML) interventions. Whereas other exercises are not so easy so she leaves time to solve them. Lesson 1 was the first time the students' used this EEB so they needed some instruction in order to be able to do it. Meanwhile in the second lesson the (IE) interventions came only from the complicated environment of the first exercise. These points illustrate the teacher's flexibility.

In lesson 1, most of the global helps came from the second exercise. Students stumble on the following difficulty: it was not obvious that divide by 3 was the same as multiply by  $1/3$ . In the interview, Flore said she had not even anticipated this difficulty. She added that in the classical lesson if a student says, "I divide by 3" she only says "Ok, very good" and never asked, "so you multiply by what?" She said that she will repeat this lesson in the next year, but she will emphasise this point at the beginning of the digital sheet. This example shows the evolution during the lesson and how one real lesson can lead to the design of a future one, in the next year.

Meanwhile, in lesson 2, global helps refer to Flore's anticipation and are relevant within the aim of the lesson: to distinguish linear functions ( $f(x)=ax$ ) and affine functions ( $f(x)=ax+b$ ). However, as the functions used in the exercises originate from random parameters, sometimes linear functions appear in exercises named "affine functions" so the students were surprised. Flore had to explain to them that linear is a specific case of an affine function. She said that, up to now, she had presented the

two types separately, and that she will explain this point in the next classical lesson. This is another illustration of an evolution during the lesson and from the ICT lesson to the classical one, in the next week.

Finally, in both cases, the mathematical explanations are both local and global, more or less, in the same ratio and the control actions are few. We then may hypothesise that there are some regularities of the couple (Teacher, EEB) that appear in the balance between global and local helps. It seems that the teacher wants to help students in the solving process and at the same time to push them towards a better understanding of the knowledge. Indeed, most of the global interventions are at the beginning of the local ones.

### **Diane's case, aspects of her professional evolution**

Diane's case is specific because she was a member of our research team. Before the regional project, she rarely used ICT with her students. Her personal use of technology is limited to word processors and the Internet on a regular bases; use of specific mathematics software remains episodic. Diane can be considered thus as being a 'middle teacher' that hasn't made extensive use of technology in her professional activities. In her answers to questionnaires when she started in the project, she stressed that her main goal in an exercises-based lesson is to enable students to have a "good solving process", merely answering correctly to MCQs is not a guarantee of learning. Let us see how the activity model allows us to report on her attitude and professional evolution.

More than a year after the experiment's beginning, we observed her in a lesson with an EEB that provides hints. We observed in this lesson 45% of (MH), among these helps, control and validations are infrequent. Thus, Diane seems to let this function be controlled by the software. Her mathematical helps are oriented more towards the type of global helps. If we add the fact that 30% of her actions are of the type (IE), we can say that Diane is conscious of the potentialities of the ICT environment. She tries to make students commit in the mathematical task resolution while taking the software as a privileged 'partner' that controls the local helps and the validation of answers. Her teachers' role consists primarily in coaching this partnership and in helping the students to correctly use the software in order to execute mathematics tasks. Her intervention on the mathematical plan consists in helping students to either review or strengthen the mathematical knowledge mobilized in the proposed tasks. This illustrates an aspect of the triad between subject, instrument and object.

At the beginning of the second year, she asks her students to use a 'computer notebook' where they have to note down the solving steps in order to keep 'a trace' of the method used. She said in the questionnaires that these writings also help them to be more autonomous, and to be able to use the EEB at home. We also noticed, in the observed lesson, that among the (ML), 27% are concerned with using paper and pencil. This also confirmed her idea about keeping traces of the activity in a technology environment in order to have it available when working autonomously.



We can also assign this requirement to a professional evolution owing to her work/discussions within the group of researchers. This also made Diane want to show her students the link between lessons in EEB environment and lessons in paper-pencil environment, by adding in topics of exams, either by screen-copies of EEB or similar exercises, to those already resolved in EEB lessons. These examples show the connections between personal beliefs and community influence and the effect on the object: mathematical teaching.

Another remarkable aspect in the observed lesson is that Diane knew perfectly all the exercises that the students were working on. Her explanations (IE) about how to use the software to do these exercises were thus generally very efficient. These results show that the professional evolution of Diane takes into account more the specificity of the ICT environments in prep work and class work.

## **DISCUSSION AND PERSPECTIVES**

We believe firstly to have exhibited an aspect of the practices' complexity by describing the dynamic feature of the teaching process. Indeed, Flore's lessons show professional evolution in the short term, i.e., during the lesson, in the middle term, i.e., from the lesson to the classical course and in the long term, i.e., from the lesson to next year lessons. Secondly, we illustrate how this dynamic process came from internal and external negotiations. Effectively, Maurice's case supports the hypothesis that the choice of the EEB and tasks is a compromise between the community, the EEBs on offer, the curriculum adapted to EEBs and the teacher own conception about how to teach mathematics. Meanwhile, Diane's case shows the changes she made in her mediation between instruments and the mathematical activity of the students (objects). These changes are determined by her conception of the teacher's role in the learning process especially in an EEB environment. It also shows how interactions between researchers and teachers (considered together as a community) could have an impact on the teachers' professional evolution.

We now want to face up to the crucial question: "how to use these results in teacher education?" From our report on the attitudes' diversity and complexity, it appears that it is difficult to conclude what the prescriptive pre- and in-service teachers' trainers might be. However, it would be interesting to prompt teachers to inquire about their own teaching representations and professional evolutions. For instance Diane's case shows that she made changes in her practice that are strongly linked to her growing awareness of the instruments used. This awareness was made so that her actions in an ICT lesson were more efficient and more productive. Whereas in a previous research about pre-service teachers training (Abboud-Blanchard and Lagrange, 2006) we highlighted that despite the trainees' increasing awareness of the specificity of ICT environments, this doesn't lead to a consequent reflection about real integration of ICT in their practices. How teachers, like Diane, are able to transform their knowledge about technology in 'producing' efficient practices may be an issue to ICT teachers' education.

One of our future perspectives is to continue to investigate teachers (in-service ones) professional evolution in their ICT practices. This issue is in alignment with our work on the professional development within the GUPTEN project: Genesis of Professional Usages of Technology among teachers.

## REFERENCES

- Abboud-Blanchard, M., Lagrange, J-B.: 2006 ‘Uses of ICT by pre-service teachers: towards a professional instrumentation?’ *International Journal for Technology in Mathematics Education* 13(4), 183-190.
- Artigue, M. : 2006 ‘L’utilisation de ressources en ligne pour l’enseignement des mathématiques au lycée : du suivi d’une expérimentation régionale à un objet de recherche’, *Colloque EMF 2006*, Sherbrooke, Canada, Mai 2006.
- Cazes, C., Gueudet, G., Hersant, M., Vandebrouck, F.: 2006 ‘Using E-Exercise Bases in mathematics: case studies at university’, *International Journal of Computers for Mathematical Learning*, <http://www.springerlink.com/content/1573-1766/?Content+Status=Accepted>.
- Engeström, Y., Miettinen, R., Punamäki, R.-L.: (Eds). 1999. *Perspectives on activity theory*. New York: Cambridge University Press.
- Jaworski, B.: 2002 ‘Tackling complexity in mathematics teaching development: using the teaching triad as a tool for reflection and analysis’, *Journal of Mathematics Teacher Education* 5-4, 351-380.
- Jaworski, B., Goodchild, S.: 2006 ‘Inquiry community in an activity theory frame’, *PME30*, 3-357.
- Monaghan, J.: 2004 ‘Teachers' activities in technology-based mathematics lessons’, *International Journal of Computers for Mathematical Learning* 9, 327-357.
- Robert, A., Rogalski, J.: 2005 ‘A cross analysis of the mathematics teacher’s activity. An example in a French 10<sup>th</sup> grade class’, *Educational Studies in Mathematics* 59, 269-298.
- Ruthven, K. and Hennessy, S.: 2002 ‘A practitioner model of the use of computer-based tools and resources to support mathematics teaching and learning’, *Educational Studies in Mathematics* 49, 47-88
- Wertsch, J.: (Eds) 1981 *The concept of activity in Soviet psychology*. Armonk, NY: Sharpe

# **EXPRESSING GENERALITY: FOCUS ON TEACHERS' USE OF ALGEBRAIC NOTATION**

Claire Vaugelade Berg

Agder University College, Norway

*This paper is related to my ongoing research concerning the possibility to enhance teachers' algebraic thinking through the creation of a learning community consisting of three teachers and a researcher. It explores teachers' reflections when engaging in a mathematical task related to elementary algebra in collaboration with a researcher. Issues concerning the different steps in teachers' reflections, their use of symbolic notation and its relation to algebraic symbolism are addressed. Possible consequences for teacher education are also discussed.*

## **INTRODUCTION**

Previous research has underlined the difficulties students meet when they engage within mathematical tasks involving the use of algebra. Some of the difficulties are related to the interpretation of letters (Küchemann, 1981) or to the understanding of certain structural aspects of school algebra (Kieran, 1989a). Further investigations have focused on the use of history of mathematics as a source of insights in the difficulties students have with algebra (Harper, 1987; Sfard, 1995). Taking another perspective, the teacher's perspective, Kaput and Blanton (2001, 2003) introduce the notion of "algebrafying the elementary mathematics experience", a process including the following three dimensions: the process of building task opportunity for generalization; building teachers' *algebra eyes and ears* in order to enable them to spot opportunities for generalization and systematic expression of that generality; and creating classroom practice and culture supporting such work. In this article the focus is placed on the second dimension and central questions are: what is meant by "teachers' algebra eyes and ears"? And by which means can these be developed?

## **THEORETICAL FRAMEWORK AND METHODOLOGY**

Based on Wenger's (1998) "communities of practice" and on Jaworski's (2004) "inquiry communities in mathematics teaching development", a learning community consisting of three teachers (lower secondary school) and a researcher is studied and the participants' emerging reflections are analysed and presented. The aim of the research is to look at the way in which establishing a learning community can offer to the teachers an opportunity to develop a deeper understanding of algebraic thinking. One of the central features of the design of this study is the creation and development of mathematical tasks, by the researcher, which may provoke teachers' reflections concerning algebra, and enhance their awareness concerning the learning and teaching of algebra. These tasks, proposed during the workshops, are created or found as a means to provoke teachers' reflections, and at the same time the tasks allow the

participants to work together. In other words, the problems are instruments both to the development of algebraic thinking and to the building of the community.

### **Addressing algebraic thinking**

The importance of generalization in relation to algebraic thinking is underlined by Mason et al. (1985):

Generalization is the heartbeat of mathematics, and appears in many forms. If teachers are unaware of its presence, and are not in the habit of getting students to work at expressing their own generalizations, then mathematical thinking is not taking place. (p.65)

As underlined by Mason, the process of expressing generality is central in mathematical thinking and an alternative to the tendency to rush towards the use of the symbol “x”, is to devote time to the prior stages consisting of “Seeing” and “Saying” (Mason et al., 1985). Here “Seeing” refers to:

... grasping mentally a pattern or relationship (“seeing the pattern may occur after a varying period of time and number of particular examples), and is often accompanied by a sense of elation or insight. (p.8)

While “Saying” might be characterized as:

“Saying”, whether to oneself or someone else, has more to do with the attempt to articulate this insight in words. (p.8)

The last step in expressing generality is to “Record”, or to make language visible:

“Recording” involves the move to symbols and written communication (including pictures); sometimes which is often found to be difficult both by children and adults alike. (p.8)

A way of addressing these difficulties is, according to Mason, to spend more time on the prior aspects of generalization, to focus more on the stages of “Seeing” and “Saying”, in order to prevent premature use of symbols.

This view is further developed by Kieran (1989b), arguing that the activity of generalizing is not sufficient in order to characterize algebraic thinking:

I suggest that, for a meaningful characterization of algebraic thinking, it is not sufficient to see the general in the particular; one must also be able to express it algebraically. Otherwise we might only be describing the ability to generalize and not the ability to think algebraically. Generalization is neither equivalent to algebraic thinking, nor does it even require algebra. For algebraic thinking to be different from generalization, I propose that a necessary component is the use of algebraic symbolism to reason about and express that generalization. (p.165)

The issue at stake is to consider how students, and teachers, use algebraic symbolism in the process of reasoning and expressing generalization. Another important notion is that of “transparency”. Adler (1999), referring to teachers working in multilingual

classes in South Africa, describes how mathematical talk, by becoming too visible, is the object of attention rather than a means to work on mathematics. I will, in this article, extend this notion to the use of manipulative.

Both Mason's, Kieran's and Adler's perspectives are relevant for the analysis of the data presented in this article which puts emphasis on the different steps observed during the process of generalization, including teachers' use of symbolic notation to represent the result of that generalization. Before presenting the data and the analysis, a short overview of the study is given.

### **A six-step developmental and analytical model**

In order to study the collaborative learning in algebra and to identify different layers of teachers' reflections, a six-step developmental and analytical model has been elaborated and it consists of several levels including working and reflecting collaboratively with the three teachers on mathematical tasks related to algebra and following and observing each teacher in his/her class. The focus in this iterative cycle is on the development and refinement of teachers' reflections in relation to algebraic thinking. All the workshops and classroom observations have been audio-recorded and transcribed. Additional data consists of field notes and personal reflections from the didactician/researcher. The plan for this study was to follow the teachers during one year. Since it is not possible in this article to present data from one complete cycle, including the six steps, I will rather concentrate on presenting the analysis of the data from one of our workshops.

### **Working within a co-learning paradigm**

This research is situated within the co-learning inquiry paradigm (Jaworski, 2004) in which the engagement of both practitioners and researchers is one of the main features. In this way, being involved in action and reflection collaboratively enables the participants to achieve a deeper understanding of both their own world and the world of the other. The research project is based on the design-based research paradigm, and according to Kelly (2003) research design can be described as an emerging dialect whose operative grammar is both generative and transformative. It is both generative by creating new thinking and ideas, and transformative by influencing practices. According to Wood and Berry (2003), design research can be characterized as a process consisting of five steps: the creation of physical/theoretical artefact or product; an iterative cycle of product development; the deep connection between models and theories and the design and revision of products; the acknowledgment of the contextual setting of development and the fact that results should be shareable and generalizeable; and the role of the teacher educator/researcher as an interventionist rather than a participant observer.

As the aim of my research is not the development of a special type of mathematical tasks, the tasks proposed to the teachers during the workshops have to be considered as tools whose purpose is to provoke, enhance, and give the opportunity for

deepening of teachers' reflections concerning elementary algebra. Therefore I agree with Jaworski (2005), arguing that:

However, design research talks particularly of a *product* emerging from the design research process, and sometimes it is hard, in a teaching development context, to identify what is the product of this developmental process. We might therefore talk rather of *developmental research*, where the tools of development form the basis of what is studied and the outcomes of the research process constitute a combination of development and of better understandings of the developmental process and its use of tools. (p.360-361)

In this ongoing study I consider the “tools of development” as the mathematical tasks proposed to our community during the workshops. Regarding the “outcomes of the research process”, I consider the results of this study as offering both a developmental model (the six-step developmental and analytical model) and a better understanding of the developmental process (the development and enhancement of algebraic thinking).

The tasks proposed to the teachers during the workshops have to be considered as a means to enhance their algebraic thinking. Therefore both an *a priori* and an *a posteriori* analysis of each task are needed. The *a priori* analysis consists of choosing tasks relying on criteria related to the fact that the task has to be easily understandable and that it can be undertaken using different approaches, at least in an algebraic way. Teachers' reflections, as emerging from our workshops, are evaluated in the *a posteriori* analysis. Central issues concern the way the task motivated and offered opportunities for all participants to engage within it, the possibility to address issues related to algebraic thinking, the kind of notation the participants used during the workshop, and the possibility to trace enhancement of teachers' algebraic thinking.

## **THE MATHEMATICAL WORKSHOPS WITH THE TEACHERS**

During the year our group had eight workshops and the following tasks were proposed to the teachers: the first workshop was about various arrangements using Cuisenaire-rods, the second one concerned “what happens when we add odd and even numbers?”, in the third one I proposed an historical perspective into the development of algebra, during the fourth workshop our group was exploring Viviani's theorem, the fifth workshop was about exploring four digits palindromes, during the sixth and seven workshops we focused on the transition between written language and algebraic notation, and in the last workshop the tasks were proposed by the teachers themselves. These tasks were inspired by Jaworski (1988), Burton (1984), Mason et al. (1982), and Mason (1996).

### **Focus on the second workshop: about odd and even numbers**

In this paper focusing on teachers' use of algebraic notation, data from the second workshop are presented and analysed. During the workshops we usually met at one of the schools of the teachers, using the teachers' meeting room, and working for about two hours. The three teachers (Mary, Paul, and John) and I were sitting around a table

and we had the possibility to use a flip-chart. Mary and Paul work at the same school with pupils at grade 9 (13-14 years). John works in another school with pupils at grade 10 (14-15 years). Our meetings usually have the following pattern: first I propose a mathematical task to the teachers and we engage within it. Then the teachers are invited to reflect on the way the task has been undertaken and on the possibility to use similar tasks in their respective classes.

The task, as exposed below, was presented during our second workshop:

50. Claire: what happens when we add even and odd numbers?

After having a discussion concerning the relevance of this task for lower secondary school, John asks:

73. John: I am not sure about, what is the task now? will it be to add even numbers? this is one task, it is one task to add odd numbers, or is it a task where we can add even and odd numbers together?

74. Claire: so from the question, are these two alternatives included in the question, or?

75. John: yes, I think, but there is a possibility that I misunderstand

76. Mary: because I understood it (the task), at once, that one should take even numbers and odd numbers and put them together

77. John: you can do that

78. Mary: I did not think (John and Mary are laughing together) to take them separately

79. Claire: I thought everything was possible

After some clarification about what kind of numbers the teachers can work with, there is a long pause during which the teachers have the possibility to work on their respective note pads. Paul is the first to break the silence, explaining the result of his reflections *using words*.

81. Paul: it depends on how many numbers you take, if you take two or three (pause)

82. Claire: two or three what?

83. Paul: yes, either even or odd numbers, what ever it is, then the result will change

84. Claire: can you go a little deeper?

85. Paul: yes, look, if you just put together even numbers, so it will be, you will never see odd numbers, but if you put together odd numbers then it depends on how many numbers you take, if you take even numbers of odd numbers (laugh) to put it that way

By working out several numerical examples during the long pause, the teachers had the opportunity to grasp mentally a pattern and to get some insight into the relationship between even and odd numbers. This stage corresponds to what Mason calls “Seeing”. Then Paul explains first very briefly his result (81, 83) and encouraged by Claire’s question (84) he makes the attempt to articulate his insight (85), only using words, to the other participants. This new stage corresponds to Mason’s stage of “Saying”. Furthermore Paul’s reasoning shows evidence of “seeing the general in the particular” which is the first step in Kieran’s (1989b) characterization of algebraic thinking. The goal now for Claire is to address the next

step, the issue concerning “Recording” (Mason, 1985). The role played by Claire, in asking for developing further Paul’s reasoning, underlines the way our learning community offers to the teachers the possibility to address and enhance algebraic thinking. This issue is also visible in the following utterances.

90. Claire: can you write it (the result as explained in 85), not in words, but in a more mathematical way?
91. Paul: but I have, I have just done it this way (pointing to his note pad), I don’t know if it was what you had in mind?
92. Claire: yes, now it (the result) is written with specific numbers, but what you said, you were talking about a generalization
93. Paul: hmm, hmm
94. Claire: how would you write it?
95. Paul: oh, yes, now I understand what you ask, so, (laugh), then we have to write even numbers plus even numbers is equal to even numbers, isn’t it, is it what you?

Paul is surprised by my question (90) and he does not understand what I mean (91). He is pointing to his note pad where the numerical examples are written and the insight extracted from these seems sufficient for him. Claire refers to the process of generalization and ways to express it (92, 94) in order to move to the step of expressing that generality using symbolic notation. Here Claire, acting as a didactician encourages Paul, and also Mary and John, to move from the “Saying” stage to the “Recording” step. By taking the teachers in the step where they are, and indicating to them the possibility to move further and to use symbolic notation, fundamental algebraic issues are addressed: the process of generality that ultimately is expressed in a symbolic form which has an unambiguous commutative power and is the essence of algebra.

Paul now sees Claire’s purpose (95) and proposes to write his result using even numbers as an example. I then invite Paul to come and write on the flip chart.

- (Paul writes:  $e. n. + e. n. = e. n.$ )
98. Claire: yes, this was the first one
  99. Paul: then you have, hmm
  100. John: odd numbers
  101. Paul: odd numbers, yes, (Paul writes:  $o. n. + o. n. = e. n.$  and  $o. n. + e. n. = o. n.$ ), then it (the result) depends on the number (of odd numbers)
  102. Mary: yes, but the way you wrote it now, it is (pause)
  103. Claire: yes, and I think you said something about an odd number of odd numbers
  104. Paul: yes, then I have to look at (pause)
  105. Claire: yes, can you write down, as an example
  106. Paul: yes, if you then take, (pause), if you write, yes, (pause)
  107. Claire: if it is difficult to write it down in general terms, take three (odd numbers) as an example



108. Paul: yes, then (pause, Paul writes: o. n. + o. n. + o. n. = o. n.) and if you take this one (unclear)

The goal is to express Paul's result, as expressed in (85) and (95), using symbolic notation. According to Mason et al. (1985), this step of "Recording" involves the move to symbols and written communication. The issue at stake is: what kind of symbols? The notation introduced by Paul (o. n. for odd numbers and e. n. for even numbers) is, in a sense, expressing generality, but this notation does not correspond to the standard notation for even and odd numbers ( $2n$  and  $2n+1$ ) used in algebra. Paul's notation illustrates one of the results in Küchemann's (1981) study concerning the use of symbols. Here the first letter of the two words "even"/"odd" and "number" is used and introduced as abbreviations. This use of symbols, or considering a letter as an object, is reported as "the letter is regarded as a shorthand for an object or as an object in its own right" (Küchemann, 1981, p.104). Taking into consideration the notation introduced by Paul, Claire's aim now was to guide the teachers to the standard notation used in algebra to denote even and odd numbers ( $2n$  and  $2n+1$ ). In order to do this, Claire introduced some manipulative: small squares in coloured plastic. Here the point was to illustrate the geometrical properties of even and odd numbers. These numbers can be represented by using small squares and considering even numbers, their shape might be represented as:

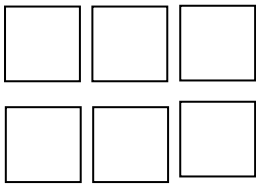

An even numbers is represented with this kind of arrangements of manipulative. The aim is to focus on the *shape* of this arrangement. All even numbers *can* have a rectangular shape.

Considering odd numbers, the shape of these numbers might be represented as:

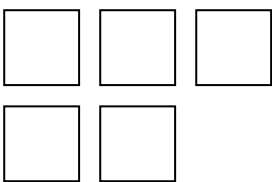

An odd number is represented with this kind of arrangement. In this case the shape looks like a rectangle with one extra square on the top or bottom row. Odd numbers *cannot* have a rectangular shape.

The task's goal is to illustrate how geometric figures can be used to deal with some problems involving even and odd numbers and to discover properties of these numbers under addition. The discussion between the three teachers and Claire developed in the following way:

117. Claire: I took these (the manipulative) with me as you see, is it possible to use these one?

118. Paul: I would have worked on numbers, I won't have thought about manipulative

119. Claire: ok?

120. Paul: automatically

121. Claire: no, ok, you would have worked on numbers, this means that you would have?

122. Mary: put in numbers here

Later in the discussion, Paul explained his arguments with these words

220. Paul: for these (the manipulative) are not numbers for them (the pupils), these are plastic squares

This short excerpt shows evidence of the differences between the teachers' and Claire's view concerning the use of manipulative. As Claire wanted to introduce these (117), Paul reacted immediately (118) and admitted the fact that he, as a teacher, would not have thought of doing this in his class. His argument is reinforced by Mary who also argued for working with numbers (122). The problem experienced in relation to the use of the manipulative (220) might be explained as a lack of transparency of the manipulative, from the teachers' point of view, as the focus was moving on the tools, away from the mathematics (Adler, 1999). Here Paul draws on his experience (220) as a mathematics teacher to refuse the use of the manipulative.

This analysis offers the possibility to focus on what Kieran (1989b) calls "the use of algebraic symbolism to reason about and express that generalization". Central questions emerging from this analysis are: Are the teachers only engaged in a process of generalization or do they show evidence of the ability to think algebraically, as underlined in Kieran's (1989b) quote? Considering Paul's notation, there is a sense of generality in it, but what are the characteristics of established algebraic symbolism that Paul's notation is missing? The next question is: is it possible to give the characteristics that symbolic notation has to fulfil in order to be accepted as algebraic symbolism?

## **IMPLICATIONS FOR TEACHER EDUCATION**

In this article the emphasis is placed on the way a learning community consisting of three teachers from lower secondary school and a researcher engage within a mathematical task related to even and odd numbers. Some features of this approach are relevant for teacher education. Looking at the role played by Claire, acting as a didactician, and offering possibilities for enhancing teachers' algebraic thinking, the parallel with the role played by the teacher educator with pre-service teachers, or by the teacher with his/her students, is central. Considering algebraic thinking and its development, it seems from this study that it is important to offer to the teachers, and therefore to the students, time to walk through the different steps referred as "Seeing", "Saying", before engaging into the more symbolic step of "Recording". Important questions for us, as didacticians and teacher educators, is how to help students to move further through these different steps, what are the means available in order to achieve this goal, and are the students in a position to appreciate that? The transition between the different steps, characterized by Mason et al. (1985) as "Seeing", "Saying" and "Recording" is not obvious and in relation to the

development of algebraic thinking, it is crucial that the teachers/students move through the three steps and reach the “Recording” step which involves the move to algebraic symbolism. In addition the difficulties related to the utilisation of manipulative illustrate the fact that issues of transparency are relevant not only in relation to language, as illustrated in Adler’s study (1999), but also in relation to the introduction and use of manipulative. The fact that the teachers draw on their previous experiences in class, as illustrated in Paul’s utterance, to justify that they would not introduce the manipulative in their class, shows that experienced teachers operate from a complex knowledge base (Calderhead, 1987). The analysis of the data, as presented here, draws attention on the different steps within the process of generalization, and offers insights into the difficulties experienced by the teachers when engaging within mathematical tasks involving the use of symbolic notation. Thereby this study contributes to clarify Kaput and Blanton’s (2001, 2003) notion of “teachers’ algebra eyes and ears”, and underlines the necessity to develop an awareness of the different steps teachers and students move through when working on tasks involving generalization. The next issues to address are the following: if this transition is not going to happen naturally, *what* can we, as didacticians and teacher educators, do to enable the transition? and *how* to take the teachers where they are, in the “Saying” or “Seeing” step, and starting to indicate a move into the use of symbols in order to express what we are seeing and saying. This demands a sort of delicate balance in order to move together with the teachers/students, and this kind of challenge represents a really important didactical issue.

## REFERENCES

- Adler, J.: 1999, ‘The dilemma of transparency: Seeing and seeing through talk in the mathematics classroom’, *Journal for Research in Mathematics Education*, 30(1), pp.47-64.
- Burton, L.: 1984, *Thinking Things Through*, Oxford: Basil Blackwell.
- Calderhead, J.: 1987, *Exploring teachers’ thinking*, London: Cassel.
- Harper, E.: 1987, ‘Ghosts of Diophantus’, *Educational Studies in Mathematics*, 18, pp. 75-90
- Jaworski, B.: 1988, ‘A question of balance’, in D. Pimm (Ed.), *Mathematics Teachers and Children*. London: Hodder and Stoughton.
- Jaworski, B.: 2004, ‘Grappling with complexity: Co-learning in inquiry communities in mathematics teaching development’, *In Proceedings of the 28th PME Conference* (volume I pp 17-32). Bergen: Bergen University College.
- Jaworski, B.: 2005, ‘Tools and Tasks for Learning and Meta-learning’. *Journal of Mathematics Teacher Education*, 8, pp. 359-361
- Kaput, J., & Blanton, M.: 2001, ‘Algebrafying the elementary mathematics experience. Part I: Transforming task structures’, in H. Chick, K. Stacey, J.

- Vincent, & J. Vincent (Eds.), *The future of the teaching and learning of algebra* (Proceedings of the 12<sup>th</sup> ICMI Study Conference, pp. 344-351). Melbourne, Australia: The University of Melbourne.
- Kaput, J., & Blanton, M.: 2003, 'Developing Elementary Teachers' "Algebra Eyes and Ears", *Teaching Children Mathematics*, 10 (2), pp. 70-77.
- Kelly, A. E.: 2003, 'Research as Design', *Educational Researcher*, 32 (1) 3-4.
- Kieran, C.: 1989a, 'The early learning of algebra: A structural perspective', in S. Wagner & C. Kieran (Eds.), *Research issues in the learning and teaching of algebra*, Reston, VA: National Council of Teachers of Mathematics; Hillsdale, NJ: Lawrence Erlbaum.
- Kieran, C.: 1989b, 'A perspective on algebraic thinking', in G. Vergnaud, J. Rogalski, & M. Artigue (Eds.), *Proceedings of the 13<sup>th</sup> annual conference of the International Group for the Psychology of Mathematics Education* (Vol.2, pp. 163-171), Paris, France: Program Committee.
- Küchemann, D.: 1981, 'Algebra', in K. M. Hart (Ed.), *Children's Understanding of Mathematics*, London: John Murray.
- Mason, J., Burton, L. and Stacey, K.: 1982, *Thinking Mathematically*, London: Addison-Wesley.
- Mason, J., Graham, A., Pimm, D., & Gowar, N.: 1985, *Routes to/roots of algebra*. Milton Keynes, UK: Open University Press.
- Mason, J.: 1996, 'Expressing generality and roots of algebra', in N. Bernarz, C. Kieran, & L. Lee (Eds.), *Approaches to algebra: Perspectives for research and teaching* (pp. 65-86), Dordrecht, The Netherlands: Kluwer.
- Sfard, A.: 1995, 'The development of algebra: Confronting historical and psychological perspectives', in *New perspectives on school algebra: Papers and discussions of the ICME-7 algebra working group. Journal of Mathematical Behavior (Special Issue)*, 14, 15-39.
- Wenger, E.: 1998, *Communities of practice: Learning, meaning and identity*. Cambridge: Cambridge University Press.
- Wood, T. and Berry, B.: 2003, 'Editorial: What Does "Design Research" Offer Mathematics Teacher Education?', *Journal of Mathematics Teacher Education*, 6, 3, pp. 195-199.

## **STRIVING TO ‘KNOW WHAT IS TO BE DONE’: THE ROLE OF THE TEACHER**

Laurinda Brown and Alf Coles

University of Bristol, Graduate School of Education

*We develop a concept of the ‘teaching third’, adapted from Ogden’s (1994) discussion of the ‘analytic third’, which we have found useful in describing our role and decision-making as teachers in a secondary school classroom in the UK. In this paper, we discuss our states of mind when teaching and illustrate the interplay between our studies of the practices of teaching mathematics and implications for theories-in-action in teacher education.*

And he is not likely to know what is to be done unless he lives in what is not merely the present, but the present moment of the past, unless he is conscious, not of what is dead, but of what is already living. (Eliot, quoted in Ogden, 1994)

The way one word follows another, with the conversation taking its own twists and reaching its own conclusions, may well be conducted in some way, but the partners conversing are far less the leaders of it than the led. No-one knows in advance what will ‘come out’ of a conversation. (Gadamer, 1989, p. 383)

### **MOTIVATION**

We work together in Alf’s secondary mathematics classroom at most once each week and have done for the last ten years. Recently we were asked by the editor of a professional journal for some writing that would give insight into the complexity of the worlds of the classroom. What follows is the beginning of a conversation that took place through e-mail, relying on research notes taken by Laurinda as an observer on October 9<sup>th</sup>, 2006:

Laurinda: I was sitting at the back of your classroom and you were using what we refer to as the Gattegno chart [see Figure 1]. Your year 7 group was chanting, “three point two; three point four; three point six; three point eight; three point ten”. Your pointer was following their chant by a fraction of a second and you looked around with nowhere to point. I remember laughing - enjoying the moment, “four; four point two; ...”, it was “five” next time around. I stood in front of my new group of student teachers and we began chanting. “three point two; three point four; three point six; three point eight; four; four point two”. No laugh this time. Rather than them experience chanting exposing a problem through the saying of “three point ten”, I’d have to tell them the story from the classroom! Not the same. It was only on reflection afterwards that I realised that I could have raised the level of complexity until there was something to work on at their level. I had an attachment to “3.10” happening, wanting it to happen.

On reading the conversation, Dick Tahta commented that the teacher in a classroom needs to take the “wanting out of waiting” (personal e-message; Dick died in December, 2007). Can anything more be said about all this?

0.01	0.02	0.03	0.04	0.05	0.06	0.07	0.08	0.09
0.1	0.2	0.3	0.4	0.5	0.6	0.7	0.8	0.9
1	2	3	4	5	6	7	8	9
10	20	30	40	50	60	70	80	90
100	200	300	400	500	600	700	800	900

**Figure 1: The “Gattegno” chart**

## METHODS

We look at the detail of our practice, what we do, using the strategy of giving ‘accounts-of’ (Mason, 2002, p. 268) significant incidents for us, often recognised through dissonance (Festinger, 1957; Brown and Dobson, 1996) and reflecting on, or accounting for those incidents to probe our motivations and implicit beliefs and theories (Claxton, 1996). The research process of interacting theory and data with the re-tellings of the stories (Bateson, 1979; Bruner, 1990) from our practice over time is essential to our work since, in itself, the creation of narrative (Clandinin and Connelly, 1991) forms part of an holistic sense, which in our cases allows us to raise issues and questions for future exploration and makes us aware of our developing theories-in-action (Schön, 1991).

In earlier writing it has become apparent that we are not probing the students’ thinking as a prime motivation in our teaching. In a paper about Sarah, the theory-in-action which seemed to be operational was that, in her world, she was convinced of her answer for a reason. It was not the primary task of the teacher to discover this reason but to offer things from their world to which she would need to adapt hers.

My attention being on looking for that which I do not understand or which makes me uncomfortable when talking with a student is a necessary precondition to noticing what is there and then acting. (Brown and Coles, 1997, p. 119)

However, from this earlier writing and from the story at the start of this paper we see parallels between the active listening done as part of the psychoanalytic process and the listening done by teachers in interaction with their students either one-to-one or whole class. Any attachment to the analysis and reflection done outside of the classroom, as in the case of Laurinda’s attachment to the experience in Alf’s classroom, distracts the teacher from the process of learning going on here in this space of this classroom by these students. As questions arise we find that often our wider reading supports our thinking as we strive to “know what is to be done” as teachers in our classrooms. We started reading in the psychoanalytic literature and

this paper documents our interpretations of our actions in the light of reading a particular paper by Ogden (1994).

### THE ANALYTIC THIRD

In trying to describe the state of the teacher who adapts to what is offered by the students, the words “free-floating attention” (a term of Freud’s) seemed the closest. We were struck by parallels in the language used to describe analysts’ states of mind during consultations and those of our classroom incidents.

Ogden (1994) proposes that in an analytic session analyst and analysand create a common experience, an ‘intersubjective’ experience - differently felt and interpreted by each but nonetheless something commonly generated. The analyst will not try and interpret what is happening inside the analysand’s subjectivity, but interprets their interactions in the session, their current relationship *i.e.*, interprets something intersubjective. This intersubjectivity is named the “analytic third” (“third”, because it co-exists with the individual subjectivities of analyst and analysand) by Ogden. He proposes viewing the analyst’s task as that of:

using verbal symbols to speak with a voice that has lived within the intersubjective analytic third, has been changed by that experience, and is able to speak about it.

A second strand in Ogden’s 1994 article is a description of what he has come to understand by the quotation from T. S. Eliot given at the start of this paper. Ogden’s concern is informing his practice, in striving to “know what is to be done”. In his concluding comments to the paper he writes:

As the analytic third is experienced by analyst and analysand in the context of his or her personality system, personal history, psychosomatic make-up, etc the experience of the third (although jointly created) is not identical for each participant. Moreover, the analytic third is an asymmetrical construction because it is generated in the context of the analytic setting, which is powerfully defined by the relationship of roles of analyst and analysand. As a result, the unconscious experience of the analysand is privileged in a specific way, *i.e.*, it is the past and present experience of the analysand that is taken by the analytic pair as the principal (although not exclusive) subject of the analytic discourse. The analyst’s experience in and of the analytic third is, primarily, utilised as a vehicle for understanding of the conscious and unconscious experience of the analysand (the analyst and analysand are not engaged in a democratic process of mutual analysis).

### THE TEACHING THIRD

We started to talk about the ‘teaching third’ after having read this article and in one-to-one conversations in the classroom the direct parallels are marked:

A student is solving the equation:

$3(x + 1) = 9$  and writes  $3x + 3 = 27$  as the next line of their argument.

This argument is coming from the subjectivity of the student and the teacher on observing this error can tell stories from their subjectivity about why that error might have been made. One story, which seems to make a lot of sense, is that the student is misapplying a rule of ‘multiply both sides of the equation by three’. There are other stories that could be told but what is the teacher to offer? In striving to “know what is to be done” there will follow a sequence of events in the present, informed by the pasts of teacher and student, but unique to this encounter, which might include other members of the class, the whole class or simply an interaction between the two. How can the student recognise their own error? The task seems not so much to find out what is in the student’s mind, because in the Ogden sense that is not necessarily possible. There can, however, be a sharing within the ‘third’ where the teacher works with their wider experiences of teaching and mathematics so that the student reconstructs, in the present moment, their manipulation of the equation. One aspect of this interaction is that the student comes to recognise that there is indeed a problem and works to build a more complex model. Often, in this third space, simply focusing the students’ attention on the two statements can be sufficient. The student might recognise what they have done to be a simple misapplication, a slip or be provoked to try, say, substituting in numbers and recognise that there is a different value for  $x$  satisfying each statement. All these events are complex since it all depends on the web of connections which have been built up by this student and, although for common errors, the teacher may have quite well-rehearsed offers to provoke movement, no two explorations can be exactly the same.

(Diary extract, Laurinda, 03/12/97)

What is being privileged in this classroom is the mathematical worlds of the students and we, as teachers, have far more experience of that world. As Alf wrote:

I am increasingly seeing a crucial part of my role, as teacher, as that of providing the function, for the class, of speaking *about* the classroom experience (*e.g.*, highlighting an example of mathematical thinking or pointing to something arbitrary that needs to be learnt). I am able to do this because of my subject knowledge and previous experience of teaching. I do recognise the sense of the generation in a class of a common focus, a common experience - felt differently by each individual, but still an intersubjective experience. From my experience of this ‘third’, I attempt to become aware of where the class focus of attention and interest is, what they are finding difficult, what they do not seem to have recognised; all of which determines the decisions I make.

In speaking *about* we mean the idea of meta-commenting (Bateson’s metacommunication, 1973, p. 150) in that the teacher talks out of their experience of doing mathematics and teaching mathematics in relation to the learners’ actions, leaving the doing of mathematics itself to the learners. This distillation provides a theoretical notion that is possible to offer student teachers of mathematics. How do they want their students to work? What sorts of actions support their students in the learning of mathematics? Being explicit about these aspects, for instance, ‘looking for simpler cases’, ‘looking for patterns’ and ‘getting organised’ will support the learners in student teachers’ classes becoming able to enter the developing culture of their



mathematics classrooms. Alf and I started talking about the ‘teaching third’ as having the function in the classroom of allowing transformation of ideas for both teacher and students.

## INTERPRETING AN ANECDOTE

In the classroom anecdote and interpretation that follows we illustrate how the notion of a teaching third currently informs our practice as teachers, teacher educators and researchers. The class is a year 7 special needs group. There are twelve students, selected out of a half-year of around a hundred, whose needs, felt by their teachers, could not be met within a mixed ability setting. It is the third lesson on an activity called *Frogs* where the task is to find the minimum number of moves needed to interchange the positions of counters. Moves can be sliding into an empty space or jumping over one other counter into an empty space.

One of the first students to arrive is Penny, who was away for the first two lessons on this activity. I arrange some chairs at the back of the classroom. Tom arrives, who had also been away for the last two lessons. Their homework from the last lesson was to write up *How to play frogs* and to explain how to do it in 15 moves with three people on each side (we had established this as the minimum number of moves when doing it practically at the start of the first lesson). Sally and Janie came in saying they wanted to show me their homework, so did John. John had written out a system for solving the three-a-side problem and wanted to try it out with six people to see if it worked.

Alf: Okay, everyone, because Penny and Tom have missed what we have done so far on Frogs, I'd like to begin by doing it again on chairs at the back, so that they can see what this is about. John has shown me his homework and he has written out a system that he'd like to try out to see if works in 15 moves, so can you three and you three, go onto the chairs at the back ...Yes, Penny and Tom you have to be on chairs, otherwise you won't learn how it works.

John: E [to himself] ... that's you ... to D [again, said to himself, then looking up and pointing] there ... then C ... Penny ... to D ... there [pointing].

As he continued, the class picked up his system of classifying the chairs and so for the last few moves he simply said, “C to E ... D to C” and the students knew what to do. It came out as 15 moves.

John: I can do it for four on each side as well, it comes out as 24 moves.

Alf: Great, we'll try that in a minute, but I just want to see if the people sitting here can do it in 15 moves without being directed.

The group do it twice in 15 moves, two or three students point to who they think should move where and one student, Kylie, waves her arms, saying “No!, back!” when she disagrees with a move. In terms of going for the minimum number of moves, her sense of ‘false’ moves is correct each time, and is followed by the others. John then had to go to a music lesson at this point.

Alf: Okay, let's see if we can do it, without being directed, for four on each side.

Twenty-four moves is what it takes. They try it again. Again twenty-four. There is a table of results on the board from last lesson, with the minimum moves for 1, 2, 3-a-side. I [Laurinda] now write in the result for 4-a-side.

Students: Can we try it for 5?

Alf: Yes! Can anyone predict how many moves it will take?

Students: Thirty; Thirty-one; Thirty-five.

Alf: Okay, we'll see ...

They swap in thirty-five moves. I write that on the board as a second attempt also ends in thirty-five moves.

Students: Can we try six?

Alf: Okay, but can anyone say how many moves it will take?

Student: It's going up in twelves. (The student who said this had recently been writing out multiples of 12. One story I have of where this comment came from is that he recognised as being in the 12-times table and perhaps thought 35 was as well.)

There are several guesses, Alf: "What is it going up in?"

Alf goes to the board and they generate forty-eight as the prediction for the number of moves for six-a-side. Laurinda joins in to make up the numbers for six-a-side. We try it twice and both times the process comes out as forty-eight moves. There are now three or four people, Kylie being one, who wave arms at any 'false' moves and who prompt 'correct' ones.

### **SOME OF ALF'S THOUGHTS AFTER READING THE ANECDOTE**

In planning, I had thought about the possibility of doing the activity actively at the start of the lesson. I was aware that for some, when they came to try and do it on their own with counters, they would not be able to translate their physical awarenesses of where and when to move with the chairs. When Penny arrived, saying she had been away and asking what we had been doing, I had a strong sense that it would be impossible to explain to her what the activity is about and I started putting out chairs at the back of the class.

I decide to let John have a go at directing others from his written account. This sense of going with what a student brings to class is something I did not recognise when I began teaching. I would have planned a beginning and, for me then, students coming up to tell me about their homework was a distraction.

A change in my teaching related to working with ideas of intersubjectivity is that of allowing more time and space in my classroom for as many students as possible to become involved in what is going on. Previously, I may have been concerned about what was happening for Kylie (a higher achiever in this group) and so gone straight

on to trying 4-a-side. My sense of delaying here was that it allowed others to develop their awarenesses of what moves to make and avoid, contributing to an increasingly intersubjective focus of attention.

I had not thought of carrying on so long actively at the start of this lesson. The decisions felt led by the students; at this stage, as much their agenda as mine.

This is a class where there is often some name calling and where mistakes can be highlighted by others in the group. I was not aware of these things happening this lesson, which is evidence for me of students not being focused in their own subjectivities. An important element of this is that several students entered the class with something they wanted to share. The background structure of writing up also feels important. I did not sense that the writing was something I had to make them do. This was part of what we do and has been accepted by them. It was in the intersubjective space and was not questioned.

In my planning for some lessons I will work on the mathematics of the situation or problem that I am to offer to the class. I will attend to what I am using from my mathematical experience to work at the problem, where potential difficulties might lie, where the problem could go, and decide on a beginning. As I enter the classroom all that planning is in my past. I attempt to be ‘present’ with the class, *i.e.*, attending and responding to whatever feedback I get. However, my decisions are informed by the planning I have done and by my knowledge of the problem. There may be events which happen that I considered might happen in planning, but in the moment of action they are ‘created anew’ in the experience generated between me and the class.

## REFLECTIONS

There is evidence in this anecdote of learners taking the lead, directing the lesson. The typical roles of teacher and student are blurred as the students are the ones wanting to extend the pattern and see what happens with bigger numbers. Several students also take on the role of checking what each other does. Although there are no explicit “meta-comments” about the process, given that a culture of mathematics lessons being about doing mathematics has already been established, Alf still suggests twice that the group needs to make predictions (a comment out of his experience of doing mathematics) and seems to have a role in checking all the class are involved. The activity allows Alf to see physically what sense the students are making of the task as they swap chairs. The students are also used to listening to each other in mathematics lessons and asking their own questions.

One of the ways we now think about our mathematics teaching is that our task is the creation or rather facilitation of an intersubjective space in the classroom, the ‘teaching third’. In this space we, learners and teachers, can work on the meaning we attach to symbols, on expressing and adapting what we are aware of in any situation. In our experience, we undergo change as well as learners. We try to create situations where we can respond to them, where they are heard and where what they say

matters. There is a flow, a developing set of complex experiences which forms the story of the mathematical experiences within the ‘teaching third’, making the decision-making itself make sense even though no two people in the room have the same experience or awarenesses. Everyone’s experiences are available in the ‘third’ and children and teachers are working in a way which has parallels with what has been called *the construction zone*:

Just as the children do not have to know the full cultural analysis of a tool to begin using it, the teacher does not have to have a complete analysis of the children’s understanding of the situation to start using their actions in the larger system. ... Children can participate in an activity that is more complex than they can understand ... While in the ZPD of the activity, the children’s actions get interpreted within the system being constructed with the teacher. Thus the child is exposed to the teacher’s understanding without necessarily being directly taught. (Newman *et al.*, 1989, pp. 63-64)

Rather than looking for ways of simplifying ideas for learners and teaching mathematics in small fragments we see our task as staying with complex problems and situations and developing a culture within the classroom that is about the students doing mathematics. The teacher, in the teaching third, mainly shares ways of doing mathematics – talking contingently upon the students’ actions. The year seven learners described here became energised in their first lesson of the year by a phrase “being a mathematician”. They enjoyed trying to say it and have been developing their understandings of this phrase through their actions and comments on their actions (meta-comments) from the teacher. The students wanted to explore how many for 4, 5, 6 ... because of earlier experiences of sequencing and its power. Alf, at the start of the year with a new group, makes a lot of meta-comments about how what his students are doing relates to what a mathematician does.

In the original story, as a teacher-educator, Laurinda could also have been in the teaching third doing mathematics with her student teachers. However, there was an attachment to wanting to recapture the same experience – which was not going to happen. There is a teaching third that exists for the student teachers and teacher educator, however, that is directly parallel with that in the classroom. The student teachers have to learn about teaching mathematics whereas the teacher educator is working with these people able to comment about the student teachers’ learning from their greater experience of teaching. From the original story, relating a classroom incident is simply not the same as working with the student teachers until there is a need for a shift at their own level of mathematics.

We are not saying that this view of teaching and learning is unique. It is simply one perspective that supports our developing practices. At CERME 5 a few of us analysed one classroom episode from our different perspectives. Although we were using different frames, we in fact all focused amongst other things on one particular transition point in the lesson, identified for different reasons. The range of perspectives enriched our ways of seeing the videotaped incident. This perspective is

offered as one way of seeking to be as a teacher as an alternative to the more traditional perspective of transmission of knowledge. The teacher and teacher educator learn about their students over time in interaction, commenting about the process, whilst the students and student teachers are doing the mathematics and the teaching. Experiences of doing mathematics together, where the teacher educator is able to work contingently, would support the development of these meta-awarenesses in the student teachers so that they might notice when the children in their classes have similar experiences and be able to comment on them.

## REFERENCES

- Bateson, G.: 1973, *Steps to an Ecology of Mind*, Paladin, Granada, St. Alban's, UK.
- Bateson, G.: 1979, *Mind and Nature: a Necessary Unity*, New York: E. P. Dutton.
- Brown, L. and Dobson, A.: 1996, 'Using Dissonance: Finding the Grit in the Oyster', in G. Claxton, T. Atkinson, M. Osborne and M. Wallace, (eds.), *Liberating the Learner: Lessons for Professional Development in Education*, Routledge, London, pp. 212-227.
- Brown, L. and Coles, A.: 1997, 'The Story of Sarah: Seeing the General in the Particular?', *Proceedings of the Twenty-first Annual Conference of the International Group for the Psychology of Mathematics Education*, Vol. 4, Lahti, Finland, pp. 113-120.
- Bruner, J.: 1990, *Acts of Meaning*, Harvard University Press, London.
- Clandinin, D.J. and Connelly, F.M.: 1991, 'Narrative and Story in Practice and Research' in D. Schön, (ed.), *The Reflective Turn*, Teachers College Press, New York.
- Claxton, G.: 1996, 'Implicit Theories in Learning', in G. Claxton, A. Atkinson, M. Osborn and M. Wallace, (eds.), *Liberating the Learner: Lessons for Professional Development in Education*, Routledge, London.
- Festinger, L.: 1957, *A Theory of Cognitive Dissonance*, Peterson, Row.
- Gadamer, H.G.: 1989, *Truth and Method*, Sheed and Ward, London.
- Mason, J.: 2002, *Researching Your Own Practice: The Discipline of Noticing*, Routledge Falmer, London.
- Newman, D., Griffith, P. and Cole, M.: 1989, *The construction zone: working for cognitive change in school*, Cambridge University Press, Cambridge, UK.
- Ogden, T.: 1994, 'The Analytic Third: Working with Intersubjective Clinical Facts', *International Journal of Psycho-Analysis*, 75(3), 3-19.
- Schön, D.: 1991, 'Introduction', in D. Schön, (ed.), *The Reflective Turn*, Teachers College Press, New York.

**“YOU DON’T NEED A TABLES BOOK WHEN YOU HAVE BUTTER BEANS!” IS THERE A NEED FOR MATHEMATICS PEDAGOGY HERE?**

Dolores Corcoran

St Patrick’s College, Dublin & University of Cambridge

*How mathematics is taught at primary school level may be just as important as what mathematics is taught. In Ireland, it is believed that students entering colleges of education already possess sufficient understanding of basic mathematical ideas to equip them to teach mathematics in primary schools. Curriculum reform is supported by a forty hour mathematics methods course. This study seeks to investigate how one student teacher’s subject knowledge in mathematics influenced a lesson on division. Indications are that a deeper and more sustained form of mathematics teacher development is called for, together with a more pervasive research-based pedagogy of mathematics.*

**INTRODUCTION**

Mathematical subject knowledge of primary teachers has only recently become a matter of public concern in Ireland (Government of Ireland, 2002). Unlike what happens in the UK, once student teachers achieve the minimum entry requirement to teacher education in mathematics and attend two modules in mathematics education during their teacher preparation course there is no further emphasis on how teachers’ mathematics subject knowledge influences or is influenced by teaching in the primary classroom. The lack of awareness of possible links between these variables is highlighted in a recent Inspectors’ report: “The majority of mathematics lessons observed were effective, but there was a mismatch between teaching and learning outcomes of the pupils” (Gov. of I., 2005, p. 51). The absence of an Irish pedagogy of mathematics<sup>1</sup> is evident as a fault line between the new mathematics curriculum (1999) introduced and supported by a dedicated in-service programme and traditional approaches to teaching mathematics that are didactic and procedural and incorporate a “strong allegiance to ‘drill and practice’” (Lyons, Lynch, Close, Sheerin and Boland, 2003, p. 382). It is also manifest in the situation where student teachers are assessed during their teaching placements along three dimensions only: the quality of planning and preparation, the quality of teaching and learning and the quality of professionalism. Such is the insignificance of mathematics among a myriad of curricular areas in which student teachers are expected to be proficient that a recent study seeking to establish a correlation between the mathematics knowledge of student teachers and their performance on teaching practice found no such link (Corcoran, 2005). This paper seeks to explore certain aspects of a particular student teacher’s mathematical subject knowledge as evidenced from the planning and teaching of a lesson on division of whole numbers to a group of 8-10 year olds.

## THEORETICAL FRAMEWORK

The concept of “subject matter content knowledge” was constructed by Shulman and together with his other construct of “pedagogical content knowledge” constitutes the thrust of this research. Shulman defines “content knowledge” as “the amount and organisation of knowledge *per se* in the mind of the teacher” (1986, p. 9). The Knowledge Quartet (KQ), introduced at the CERME4 meeting, was developed as a theoretical framework (Rowland, Huckstep and Thwaites, 2005) for analyzing the actual teaching of mathematic lessons with a view to identifying aspects of the teacher’s mathematical subject knowledge as they impact on the planning and teaching of a lesson. The KQ framework identifies four essential aspects of mathematics teacher subject knowledge. *Foundation* knowledge of the mathematics to be taught and the theory of teaching and learning mathematics includes a teacher’s attitudes and beliefs about mathematics knowledge and pedagogy. *Transformation*, or knowledge-in-action, how to re-present ideas to make them better understood by pupils resonates with Shulman’s *pedagogical content knowledge*. Transformation is manifest in a teacher’s facility with the art of question-posing and the astute choice of examples. *Connection* involves the ability to sequence material to be taught and an awareness of the relative difficulty for children of different curricular elements. *Contingency* concerns the ability to deal creatively with the unexpected direction in which a lesson may go. The KQ comprises seventeen contributory codes which are subsumed into the above four elements. It represents a blend of actual and potential knowledge, which can only be accessed in the act of teaching. Further details can be found in Rowland *et al.* (2005).

## METHOD USED FOR THIS STUDY

Máire<sup>2</sup>, whose lesson is described here, is following an eighteen months postgraduate diploma in education course (PGDE). A resourceful student on her final teaching practice, she has a degree in modern languages and has taught English in Europe and the Far East. Máire’s mathematics lesson was forty minutes long, the recommended duration in the Irish primary school timetable. The lesson was videotaped by me and later transcribed and converted to DVD. The KQ framework was used to analyze the data, which consisted of the videotape, the lesson transcript, the student teacher’s lesson notes, her written evaluation of the lesson, a post-lesson conference using video stimulated recall and my field notes. Coding of teaching acts using the seventeen KQ codes began during the lesson and was modified during later video analysis, by myself and in discussion with Máire. Máire’s lesson is rich in examples of each of the four KQ elements, but the scope of this paper permits exemplification of the first two, primarily. *Foundation* knowledge encompasses: awareness of purpose; identifying errors; overt subject knowledge; theoretical underpinning of pedagogy; use of terminology; use of textbook and reliance on procedures. The *Transformation* codes comprise: choice of representation; teacher demonstration and choice of examples. Máire’s *Foundation* and *Transformation* mathematics knowledge for teaching is overt right from the beginning of the lesson.

She espouses a teaching objective, which she rehearses repeatedly, that children would articulate their thinking as they problem solve. Yet, ironically, it is Máire's own thinking about division of number and how it should be done which is most often articulated throughout the lesson.

### PLANNING OF THE LESSON

The lesson was planned by Máire to teach the operation of *division* from the *Number* strand of the Primary Mathematics Curriculum (Gov. of I., 1999) to children in a combined third and fourth class in a middle-class, single-sex, city school. Her willingness to be videotaped in the first week of her placement indicates a degree of confidence in both her mathematical and teaching abilities. Her beliefs about the teaching of mathematics emerged during the post-lesson discussion. Máire's intentions and actions in adopting a radical constructivist approach to the teaching of mathematics (Glaserfeld, 1995) highlight difficulties often experienced by novice teachers in problem-posing, use of concrete materials and choice of representation (Cobb, Yackel and Wood, 1992). She is unusually innovative in that she used a Harry Potter context<sup>3</sup> to situate the operation of division and further, invented one and two-step word 'problems' so that pupils might practice the operation, 'in context'. Ostensibly, the lesson was well resourced, in that each student was given a sheet of problems and concrete materials to work with. Her learning objectives were also innovative. These were to enable the children to:

- Work through simple problems using concrete materials as they go
- Articulate their thinking
- Consider the idea of remainders in a natural context
- Write about their thinking.

### Sources for planning

My contention that there is insufficient pedagogy of mathematics in Ireland has a basis in the paucity of resources, which teachers can access for guidance as to how they might approach the teaching of any particular mathematical topic. The national curriculum, from which this lesson is drawn, mandates that in third class:

*the child should be enabled to*

- Develop an understanding as division as sharing and as repeated subtraction, without and with remainders

*Share a quantity in equal groups of 2, 3...*

*Record using number sentences or vertically*

$$20 - 4 - 4 - 4 - 4 - 4 = 0$$

- Develop and/or recall division facts within 100  
*Use inverse of multiplication facts*



*Use halves*

*9 is half of 18 ( $2 \times 9 = 18$ )*

- Divide a one-digit or two-digit number by a one-digit number without and with remainders

*Represent division as repeated subtraction*

*Represent division as number sentences*

$$20 \div 4 = 5$$

*Record using the division algorithm*

*Use different strategies to estimate quotients and check answers*

*Rounding up or down, e.g.  $44 \div 12$  is about  $40 \div 10$*

- Solve and complete practical tasks and problems involving division of whole numbers

*Problems based on the environment*

*How many cars are needed to take 27 children to a game if only 4 children are allowed in each car?*

*Estimate, discuss and record.*

(Gov. of I., 1999, p. 67)

The fourth class mathematics curriculum content requirement repeats the first two objectives but without exemplars and is different only in requiring the division of a three-digit number by a one digit number without and with remainders and the use of calculators to check estimates. There is little recognition here of the inherent complexity of different models presented by different situations for division. A similarly ‘straightforward’ and ‘simple’ approach to teaching division is adopted by the class textbook, which begins division by sharing exercises and then invites children to “make these [arrays of ten, twelve and 32 shapes] into groups of 2, 4, 8...” (Barry, Manning, O’Neill and Roche, 2002). The accompanying *Teacher’s Resource Book* which seeks to explain the rationale for activities in the textbook indicates that “sharing” is a good starting point for division, which is then structured as repeated subtraction of the number of groups required. Later, the text book “introduces the notion of groups [as] different in essence to sharing which was based on distributing items one at a time. Grouping entails distributing equal groups, i.e. a group at a time.” (O’Loughlin, 2003, p. 23). Awareness of the different structures for the operation of division is an aspect of teacher knowledge, which is included in the KQ as *Foundation* knowledge under the contributory code of *theoretical underpinning of pedagogy*. In planning her lesson, Máire appears to be unaware of the possible, different structures of division.

## ANALYSIS OF THE LESSON

### Choice of Examples

The KQ identifies choice of examples and choice of representations as important indicators of mathematics knowledge for teaching (Rowland *et al.*, 2005). In Máire’s lesson, third class was encouraged to use butter beans to model the division problems and fourth to use the “more sophisticated” Dienes blocks “because your numbers are bigger”. The initial word problem invented for third class involved buying “wizard cards” at a cost of 3 *galleons* per pack<sup>4</sup>. Ron and his friends had 18 *galleons* to spend and the class was invited to find out how many packs of cards they could buy. Máire asked the class how many butter beans were needed to represent the problem. The correspondence of butter beans to *galleons* and to money (euro) was established and one child counted out 18 beans in front of the class.

Máire continued to the class:

Máire: While Megan is counting out her 18 *galleons*, her 18 beans, how many groups does she need to break it into and can you tell me why?

Child: Into three groups.

Máire: Into three groups. Well done. And why?

Child: Because there’s three packs of cards.

Máire: It’s not that there’s three packs of cards. But what is it about the cards?

Child: It costs three *galleons*

Máire: It costs three *galleons*. So if you *share* out your three *galleons*, you’ll see how many packs of cards you are able to buy...

Then, turning to the child who was counting beans:

Máire: Megan you’re already ahead of us. You’ve got 18 and what are you doing?

Child: Splitting them into three groups

Máire: Into groups of three. And how many groups do you have?

Child: Six.

Máire: So how many packs of cards could Ron buy?

Child: Six.

This exchange, as Máire seeks to introduce the operation of division indicates confusion between the grouping or quotient structure of division and the more common and possibly easier equal-sharing or partition structure (Zevenbergen, Dole and Wright, 2004). Such confusion is evidenced in the first exemplar of the curriculum which advises “*that the child be enabled to...share a quantity in equal groups of 2, 3...*” Subsequent exposition by Máire drew children’s attention to the meaning of the numbers used. “What does the 3 stand for? What does the 3

represent? It's the cost of a pack of cards. Is everyone clear?" No further reference was made to the grouping process which arose from each pack costing 3 *galleons* and there being a need to find how many 3s there are in 18. Máire had attended a lecture on the teaching of the number operations of multiplication and division where the difference between sharing and grouping structures of division was emphasized. However, that distinction which is of considerable pedagogical importance is barely noted anywhere else that she might be expected to seek guidance. Máire herself appears to favour division in its inverse-of-multiplication structure, but without expressing this link for the children.

### Choice of Representation

As the lesson continued, fourth class was encouraged to represent a similar but slightly different problem: "How many Magical Worms could Fred and George buy? They have 44 *galleons* and each worm costs 4 *galleons*." This time children were encouraged to use Dienes blocks to represent the problem. Nonetheless, the  $44 \div 4$  problem that was first for fourth class was the second problem for third class using butter beans. An interesting interjection occurred when Máire reiterated the question to a small group of third class girls. "How many worms is it possible to buy at four *galleons* each, if one has 44 *galleons* to spend?" One child, exhibiting a tendency to take the problem situation literally (Cooper and Harries, 2002) recommended, "They ask the man how many they can have". Máire laughingly explained that the shopkeeper might cheat, and it would be as well to be able to work these things out for oneself. *Teacher demonstration* is the third code in the *Transformation* element of the KQ but Máire appears to consider that children should be encouraged to "use them [concrete materials] to problem solve" and resisted any impulse to demonstrate a method for finding a solution. She appears to have had an epiphany as she was helping fourth class divide the 44 Dienes blocks:

Máire: So you might need to turn those into units.... Actually.... No, we couldn't do it that way....That might be easier. Think about it and see how it goes and while you're thinking about it...Write down what you did. So write down...44 and 4 and if you multiplied it or divided it or if you added it or if you took away. OK?

In discussion after the lesson, Máire disclosed that she realised at that point that it would be much easier to divide 44 into four groups of 11 but also feared that it wouldn't fit the problem context she had created and being unsure about how to proceed encouraged the children to "think about any other way that you'd be able to do it."

Her *theoretical underpinning of pedagogy* about the structure of division was challenged again 22 minutes into the lesson when another pair of third class children suggested counting out 44 beans and dividing them between four groups. Her response was questioning. "Between four groups?" She immediately followed in a more didactic tone "So we take away beans for the worms. So take four." From the

outset, despite her emphasis on asking children to articulate their thinking, Máire promoted an understanding of division as quotition and modelled it using repeated subtraction. Sound mathematics pedagogy would claim that “for division, the basic meaning is sharing” (Zevenbergen, *et al.*, 2004, p.145) and when children learn to recognize the inverse-of- multiplication structure of division (Haylock, 2006, p.76) they will “dispense with concrete materials and begin to rely on their knowledge of basic facts or computational methods to solve the problems they encounter” (Zevenbergen *et al.*, 2004). Máire emphasized the converse of this procedure by explicitly encouraging children to model with materials rather than use any other strategies.

Máire’s *Transformation* knowledge led to her choice of  $44 \div 4$  as an opening example of the division operation. The 44 butter beans proved slightly unwieldy and there was much counting and recounting to make sure they had the right amount initially. However it was in the representation of  $44 \div 4$  using Dienes blocks that children ran into most difficulty. At the very beginning of the lesson Máire, demonstrating *Connection* knowledge, by *anticipation of complexity*, reminded the fourth class children that they could exchange tens for units if they wanted to divide the tens. Just how complex many of them found the representation of  $44 \div 4$  using Dienes blocks became apparent when she had to help them establish that there were two fours in one ten and two blocks left over, two more fours in the next ten and two more blocks left over, which her questioning established resulted in five fours with the third and fourth ten also yielding five fours. A question of how many worms could be bought with the 44 *galleons* at that stage resulted in the response “14 worms actually”, which was quickly corrected by the teacher to “11 worms, because the four units on their own would buy one worm.” Perhaps a more thoughtful teacher might have chosen a different representation or a less confident one might have relied solely on text book examples.

### Foundation Knowledge

Máire’s inherent strength as a teacher of mathematics emerged when she worked with one pair of children in fourth class:

Teacher: How are you doing down here girls?

Child: We’re on problem two

Teacher: OK? So the first thing...you divided 44 by 4 and you used blocks to get to answer ... ok? So how many worms could they buy?

Child: [Indistinct] Seven

Teacher: Seven worms? So if you said ... if I got ...4 and 4 and 4 seven times...it would be 44? Does that sound right? Lets' try it. All right?

Máire herself demonstrated changing two tens to twenty units, including a neat way to “line up the units” and measure them against a ten to establish equivalence, and by

counting out the fours and questioning the children, established there were 11 fours in 44. But first she said:

Máire: So you have five tens here and five tens here and four left over.

The children acquiesced to this, so perhaps everyone realized she meant ‘five fours’ each time. In any event, Máire maintained they had written the sum correctly,  $44 \div 4$  and

Máire: Maybe you just did it in your head; maybe that’s where you went wrong.

If you had counted out the blocks you’d have got the right answer.

This insistence that modeling the division operation by repeated subtraction would ensure the right answer betrays *a reliance on procedures* which is at variance with Máire’s learning objective: that the children would problem solve and articulate and write about their thinking. Máire’s own *Foundation* in mathematical subject knowledge is evident as she presented the cognitive conflict around the children’s solution ( $44 \div 4 = 7$ ) as the inverse of multiplication, or repeated addition. Does  $4 + 4 + 4 + 4 + 4 + 4 + 4 = 44$ ? This was an excellent example of *Contingency* knowledge for teaching but was subsumed into the perceived need to demonstrate and prove that  $44 \div 4 = 11$ . In this lesson it is evident that Máire was determined to espouse the philosophy of mathematics education, which is promulgated in the preamble to the *Primary Mathematics Curriculum* (1999). She believes that doing so requires problem-based learning, teaching for understanding and use of concrete materials. She interprets the advice to reduce reliance on text books and work sheets as a call to eschew them entirely. She aims to track children’s learning and encourages them to communicate and express their thinking. All of this is admirable teacher behaviour, but much of it may be problematic in practice. Practicing teachers who were surveyed appear to interpret the message of mathematics education reform as a change only in emphasis - more concrete materials, more talk and discussion and more problems (NCCA, 2005). The acknowledgement that there is considerably more to the successful teaching of mathematics than a few minor changes would require the development over of a period of time of a particular pedagogy for mathematics.

## DISCUSSION

Máire’s struggle to teach mathematics as deduced from the videotaped lesson, according to the revised curriculum and problem-based practice to which she was introduced in college is epitomized by her statement directed to the class towards the end of the lesson “You don’t need a tables book when you have butter beans! A tables book is cheating!” And later, “No, tables books aren’t for maths, girls!” in response to a plea by pupils in third class to be allowed use their tables books, when faced with the fourth problem ( $30 \div 6$ ). In the post-lesson discussion, Máire remarked that the lecture she attended on the value of teaching strategies for acquiring number facts over rote learning of tables made a big impression on her. She saw that as reflecting a real change from how she herself had learned mathematics. As a result

she planned to teach division without alluding to multiplication tables and certainly without recourse to tables books. While this is a study of one mathematics lesson and in no way generalizable, inferences can be drawn and questions posed about the nature and purpose of mathematics teaching in primary schools, about teacher preparation for mathematics teaching and continuous professional development of primary teachers. Pedagogy is variously defined as: The function and work of the teacher; the art or science of teaching; education; instructional methods; the principles and methods of instruction. In the recent wave of curriculum reform in Ireland, teaching has become “invisible and silenced, the silent discourse of the reform process” (Sugrue, 2004, p.191). The use of the Knowledge Quartet as a means of raising student teacher awareness and enhancing their pedagogy is proving helpful in the UK (Turner, 2006). Japanese lesson study has proved efficacious in spreading reform practices among mathematics teachers in elementary schools in Japan and parts of the USA (Lewis, Perry and Murata, 2006). I am currently working with student teachers to trial both these initiatives in Ireland. Indications from this study are that a more explicit pedagogy for mathematics teaching is needed. As Máire concluded at the end of the video stimulated recall session “You need to be very clear what you are doing yourself.” We in the mathematics education community need to be very clear also about our role in helping to develop a more explicit pedagogy of mathematics which is acceptable and accessible to primary teachers.

---

<sup>1</sup> *Pedagogy* is synonymous with *didactics* a word more commonly used in Europe to mean *theory or science of teaching*.

<sup>2</sup> Máire is a pseudonym, attributed as usual to protect the student’s identity, though Miriam R. was prepared to allow me to use her real name to indicate that she collaborated in and concurred with my analysis of the lesson.

<sup>3</sup> The *Harry Potter* series of children’s novels by JK Rowling is very popular with Irish children.

<sup>4</sup> *Galleons*, corresponding to *euro* are the fictional currency in use as legal tender at Hogwart’s Academy for Witchcraft and Wizardry.

## References

Barry, K., Manning, P., O’Neill, S. and Roche, T.: 2002, *Mathemagic 3: Maths for Primary Schools*, CJ Fallon, Dublin.

Cobb, P. Yackel, E. and Wood, T.:1992, ‘A Constructivist Alternative to the Representational View of Mind in Mathematics Education’, *Journal for Research in Mathematics Education* 23 (1), 2-33.

Cooper, B. and Harries, T.: 2002, ‘Children’s responses to contrasting realistic problems: Just how realistic are children ready to be?’ *Educational Studies in Mathematics* 29, 1-23.

- Corcoran, D.: 2005, Mathematics Subject Knowledge of Irish Pre-Service Primary Teachers, paper presented at European Conference of Educational Research, UCD, Dublin, September.
- DfEE: 1999, The national numeracy strategy: Framework for teaching mathematics from reception to year 6, DfEE Publications, Sudbury.
- Glaserfeld, E., von: 1995, *Radical Constructivism: A Way of Knowing and Learning*, Falmer Press, London.
- Government of Ireland: 1999, *Primary School Mathematics Curriculum*, The Stationery Office, Dublin.
- Government of Ireland: 2002, *Preparing Teachers for the 21<sup>st</sup> Century, Report of the Working Group on Primary Pre-Service Teacher Education*, The Stationery Office, Dublin.
- Haylock, D.:2006, *Mathematics Explained for Primary Teachers*, Sage Publications, London.
- Lewis, C., Perry, R. and Murata, A.: 2006. 'How Should Research Contribute to Instructional Improvement? The Case of Lesson Study,' *Educational Researcher*, 35, 3 -14.
- Lyons, M. Lynch, K. Close. S. Sheerin. E. and Boland., P.: 2003, *Inside Classrooms: The Teaching and Learning of Mathematics in Social Context*, Institute of Education, Dublin.
- National Council for Curriculum and Assessment: 2005, *Primary Curriculum Review: Phase 1(Final Report)* NCCA, Dublin.
- O Loughlin, N.: 2003, *Mathemagic 3: Teacher's Resource Book*, CJ Fallon, Dublin.
- Rowland, T., Huckstep, P. and Thwaites, A.: 2005, 'Elementary teachers' mathematics subject knowledge: The Knowledge Quartet and the case of Naomi,' *Journal of Mathematics Teacher Education*, 8 (3), 255-281.
- Shulman, L.: 1986, 'Those Who Understand: Knowledge Growth in Teaching,' *Educational Researcher*, 4-14.
- Sugrue, C.: 2004, 'Whose Curriculum is it Anyway? Power, Politics and Possibilities in the Construction of the Revised Primary Curriculum,' In C. Sugrue (ed.), *Curriculum and Ideology: Irish Experiences, International Perspectives*, The Liffey Press, Dublin.
- Turner, F.: 2006, 'Teaching children to count: Does knowledge of theory matter?' In J. Novotna, H. Moraova, M. Kratka, N. Sthlikova (eds.) *Proceedings of PME30*. Vol. 1, Prague, p. 346.
- Zevenbergen, R. Dole, S. and Wright, R.: 2004, *Teaching Mathematics in Primary Schools*, Allen & Unwin, Australia, NSW.

# **FACILITATE RESEARCH ACTIVITIES AT THE PRIMARY LEVEL: INTENTIONAL COMMUNITIES OF PRACTICE, TEACHING PRACTICES, EXCHANGES ABOUT THESE PRACTICES**

Jean-Philippe Georget

DIDIREM, Université de Paris 7

*The program of the primary school in France asks clearly the teachers to permit the pupils to solve mathematics problems. Potentially helpful documents exist but the practices more or less do not change. We suppose that it is difficult for a single teacher to enter into this new practices and that this change can be fruitfully accompanied by a collaborative work between teachers. We also suppose that the existing documents are not accessible to teachers. They have to get them and to integrate them even if they are often far from their own practice. Thus we have built a special design based on the concept of community of practice which we study with the help of the twofold approach: didactic and cognitive ergonomics, of the teachers' practices.*

## **HYPOTHESIS AND GOALS OF THE RESEARCH**

The program of the primary school in France asks the teacher to give their pupils “real research problems, for which they have not at their disposal already tested solutions and for which more than one way of doing is possible. It's [...] the activity itself of solving the problem that is favoured with the goal in mind to develop for the pupils a research behaviour and some methodological tools: to make some hypothesis and test them, to do and to manage successive trials, to elaborate an original solution and test its validity, to give arguments.” It is also said that “[...] pupils must be put in situation of taking in charge the different tasks associated to the resolution of a problem [...]”.

Even if helpful documents exist, teachers' practices more or less do not change. Based on researches (Graven, 2004, Lenfant, 2002, Roditi, 2001) and on our own work as teacher educator, we assume the following hypothesis:

1. The potentially available information is not accessible to teachers. By accessible we mean that one can easily access and read the information on the one hand and that one can easily integrate the information into his own practice on the other hand. The distribution of several official documents accompanying the program does not give rise to perceptible changes within the practices. Our contacts with the inspectors of the French Ministry of the National Education, the pedagogical advisers and the teachers, show that the use of textbooks predominates but the “problems solving” activities proposed in these textbooks are rarely activities of research (Coppe and Houdement, 2002). Our preliminary work shows that accessibility of the syllabus should be optimised



to contribute to a change in practices. For example we find that the documents that described the syllabus and the means of achieving its goals do not speak about the transition from existing practices to new practices or about the possible cohabitation of several kind of practices nor they speak about the constraints that the teachers have to manage such as time constraints.

2. Changing his practice is more difficult for an isolated teacher than for a group of teachers and collaborative work can facilitate this change. Teachers can discuss around their encountered difficulties, put them into perspective, try to find solutions to their difficulties and so on.
3. The collaborative work is costly for the teachers and it needs different kinds of accompaniment.

Thus our work consists of studying a way to reduce the cost of the changing of practice of the teachers by searching to weaken some of constraints of these practices, by finding a “appropriate distance” (Assude and Gélis, 2002) between new and old practices. At the same time, we identify process of the practices through the filter of the twofold approach, we accompany this community following the Wenger's perspective and try to act on these process.

## **THEORETICAL FRAME**

In this section we present the two main theoretical frames involved in our work: the twofold approach, didactic centred and cognitive ergonomics centred, of the practices by Robert and Rogalski (2005) on the one hand and the frame of the communities of practice by Wenger (1998) on the other hand. We also present our articulation between both.

### **The twofold approach**

The twofold approach (Robert and Rogalski, 2005) is used for studying the existing teachers' practices. The main idea of this approach is to describe existing practices and describe their regularity and their coherence. We use the tool of *a priori* analysis for the activities of research that we propose to the teachers and make a similar analysis of the data obtained during the lessons observed. Thus we determine the tasks and the activity of the teacher and the students during lessons and this analysis permits us to describe the choices made by a teacher in his practice and to search the coherence with the constraints of his practice. We categorise elements of his practice with the help of the social, personal, institutional, cognitive, and mediative components. Essentially, the social component is about common elements within a community of teachers. Institutional component is the set of elements about official instructions, textbooks, and so on, that constrain the practice from the point of view of institutions in the full meaning of the word. Personal component groups together characteristics of a single teacher. Cognitive component is about the mathematics

embedded in the lessons and mediative component is about the elements that describe the means of the teacher to give the pupils access to the mathematical facts.

### **Communities of practice**

The concept of community of practice of Wenger (1998) was initially used in the context of knowledge management but it has then been used in mathematics education (Graven, 2004). The associated theory is relatively general and we especially use in our work the main ideas about the management of a community of practice: focus on professional knowledge sharing, motivation of the members (volunteers), freedom of the members to choose the way they want to work. Management is seen more as accompaniment than strict leadership as in Graven's work. Teachers have an existing practice with its constraints and “space of liberty” (Robert and Rogalski, 2005) and we have to take these elements into account as much as possible to favour the emergence of new practices. We also want to favour the sharing of professional knowledge between the teachers in our experiment. Comparing to (Graven, 2004), we make a more important use of the concepts of boundary objects and reification thinking of the management of the community as we will illustrate below. Researchers and teachers do not generally belong to the same communities of practice. The theory of Wenger gives use these two particular concepts for helping us to manage and analyse a community of practice.

### **Articulation between the twofold approach and the theory of the communities of practice**

The twofold approach does not pay specific attention to the processes of evolution of practice. The theory of the communities of practice can be used to think of this process in terms of management and analysis. On the other hand, we use the twofold approach to analyse, specifically in mathematics education, the practices and give evidence of the changing of practices. The study of the community, filtrated by the components of the twofold approach permits us to search and identify more systematically the constraints, the reasonable possibility of changing the practices of the teachers. Knowing better their “space of liberty”, we are more able to accompany the community and to propose tools that can give access to new practices.

### **METHODOLOGY**

For favouring the activities of research within the classes, we would like to be able to form pairs of task/technique (in the sense of the anthropological approach of didactics, Chevallard, 1999) linked to this kind of teacher's activities. Then we would like to “transmit” them to the teachers. We have made the choice to work from the existing practices, supported by the Wenger's theory, studying the resistances and the means of weakening them but we do not exclude to figure out critical tasks and techniques. In that way, this approach has similarities with the co-learning partnerships (Jaworski, 2003).

The integration of new teachers, at the beginning and along the experiment, is required in order to create the community and maintain it over a long term period. The work made with the “pioneers” can be helpful to the “novices” and elements of the practices can be shared. We contact schools and present our work, then we welcome the volunteers. Thus a first negotiable frame is given for launching this intentional community of practice, for accompanying it at distance (website, mailing-list, phone) and through face to face meetings. At the end, the community chooses the means finally engaged for working. Since the beginning, the design is composed by a website, modalities for some reports and meetings.

The website permits us to present the problems and the object of the experiment. We have chosen to restrict our work to open problems (Arsac and al., 1991) as research activities in mathematics. Essentially, it means that the text of the problem given to the pupils is short, that there is no method or solution given in the text of the problem, and that the students are familiar with the context of the problem. This is coherent with the curriculum of the primary school and such problems can be generally proposed to the pupils at any time during the year. For facilitating their adoption by the teachers, we have chosen a variety of problems to cover several parts of the syllabus.

The simple presentation of the problems on the website lets the teacher the freedom to choose the problems and how they want to propose them to their pupils. Some proofs, some solutions are given, adapted to the teachers. There is also a brief bibliography related to the sources of the problems and one book about groupwork in classrooms. Our goal is to propose a website that can be easily and simply consulted to permit the teachers to select the situations. We want to present “incomplete” resources (no or not much information about didactical or pedagogical facts) and so we hope to initiate some discussions about these chosen lacks of information during the very beginning of the experiment. Teachers propose the chosen problems to their pupils and the associated lessons are observed and recorded (audio, video) as much as possible. We also take some notes about the exchanges that occurred when we are in the schools as they also can be rich in information and they cannot be easily recorded.

For launching the community of practice, we also propose the teachers to write down some reports at the end of their lessons and to send them to the others by mail. The reports (contents and format decided by the community) should talk about their experiences with the goal in mind that they can be helpful to the other teachers. They are also means to provoke exchanges from a contextualised support that constitute later several reifications within the community of practice, some references for the teachers.

For accompanying the community, we also propose some meetings (about 3 to 4 per year) to the community if needed. During these meetings, we discuss about their practices, their experiments, their reports, the content of the website...

## DATA AND THEIR ANALYSIS: THE *GOLF* EXAMPLE

Several data are collected in this experiment: content of the website, tape-recordings, field notes, questionnaire, interviews. We will not speak about all of them and their treatment. To give a general view of our work, we search the elements, basing on the components of the twofold approach, into the data and describe the links we see with the activity of the community of practice. For example, the tape-recordings (video) of the lessons and the meetings (audio) are transformed into “narrations” (Roditi, 2001) that permit to compare the different lessons for one teacher, or between the different teachers, with our a priori analysis. Thus we can build the several components following the twofold approach that help us to categorise the elements of the practice, the constraints, their evolution and link them to the activity of the community of practice.

In this paper, we will mainly use the *Golf* problem to illustrate our work and speak about the content of the website, the reports collected, the incidence of the meetings, and beyond that, about the community of practice.

### The web site

The website gives the problems in a simple and minimalistic way, a few lines when it is possible. The *Golf* problem consists of expressing a target-number (e.g. 97) as the sum of positive multiples of two numbers (e.g. 3 and 8). One can find here four solutions ( $97 = 27 \times 3 + 2 \times 8$ ,  $97 = 19 \times 3 + 5 \times 8$ ,  $97 = 11 \times 3 + 8 \times 8$ ,  $97 = 3 \times 3 + 11 \times 8$ ). The website proposes several cases each with a different number of solutions. It proposes to the teacher two means to find all the solutions for a specific case. He also gives in a “comments” section some “elements of research and debates”. For example, this section specifies that the number of solutions can vary. The pupils can firstly search one or more solutions and then search all the solutions and find a mean to be sure to have all of them. It is not a guide but a proposal, some ideas to exploit the problem. Note that the website doesn't give a text of the problem thinking to the pupils but the teachers. Thus the teachers can or have to find themselves an acceptable text for their pupils as they can give a written text or give it orally to them.

This presentation of the *Golf* problem is a “basic” exploitation of the use of the Wenger's reification concept. Instead of giving a lot of details intended for the teachers, we give them only boundary-objects: a presentation of the problem build for their own understanding, some examples, a few and simply and shortly written elements of exploitation. Then it is within the individual identities and the community that a reification specific to the community can emerge. In other words the purpose is to choose a shape of the problem, a boundary-object, that can pass through the communities: the community of researchers, the community of the teachers educators, this intentional community of practice.

In conclusion, our presentation of the problems is different from what is done in the textbooks or other books generally conceived for teachers. We only present some aspects of the situation and we do this with the goal in mind of building an accessible and adaptable resource, easy and quick to consult. The concepts of boundary-object and reification of the Wenger's theory permit us to think this required “adaptation” and to describe it.

### The reports

As an example, we reproduce below one of the two reports written the first and the second year by the same teacher about the same *Golf* problem. These reports differ from the point of view of their format and content. The first criteria decided by the community was to speak about the terms used to present the problem to the pupils, the duration, the reactions of the pupils. The first report (not reproduced here) follows this format. Here is the second report:

1<sup>st</sup> lesson

instruction: you must obtain 41 adding up 3 and 8. You can use your calculator.

Difficulties unexpected by ERMEL:

- value of the '=' sign ( $3 \times 10 = 30 + 8 = 38 + 3 = 41$ )

- use of the subtraction in the decomposition  $(4 \times 8) + (8 \times 3) - 2 = 41$

- the use of the parenthesis in the single-line writing

- the path from searching with the in-columns to searching with the single-lines writing

- recognise the same solution when it is expressed in different ways

Duration of the lesson: 1h30 for the first phase of ERMEL and it remains 5 solutions to study.

The second report tells more about the difficulties encountered by the teacher. We remark that she makes a reference to the source of the problem (ERMEL, French books written for the teachers). This is mainly due to the use of this book by another member of the community who has promoted this book several times during the meetings and to the fact that the source of the problem was written on the website since the beginning. For the first time, she has borrowed the book at one of her colleagues to prepare her lesson.

The two lessons are quite different: the “concrete” context (compass, chisel) added the first year disappears the second year. We cannot present here the narration written about the lessons observed and recorded but the second report gives some of its characteristics: the teacher has given a bigger role to the pupils to discuss about the problem and its solving and she has been facing different problems, “unexpected” by the ERMEL book, in her practice and these are listed. She has chosen to treat these difficulties by letting the pupils taking in charge the treatment: this choice did not permit to go notably towards the solving of the problem.

This case of study shows that changing her practice is difficult here and that the mastery of a new complex situation of teaching asks for an adaptation that is not automatic. The reason here is what we analyse as a part of the personal component of her practice: when the problem is given, this teacher teaches as if pupils have to solve all the problems they encountered during the research activity even if the problems are not linked with the main goals of the given activity. Thus they do not have enough time to really search the problem itself. On the other hand, we also note that the fact of giving “concrete” expression to the problems (here with the use of the compass and chisel) has been evoked as natural and obvious during several meetings so it was an element of the social component of the teachers' practice. It is a belief which was generally well shared at the beginning of the experiment and which has evolved. Along the meetings and the lessons, this constraint has been weakened along the discussions and the experiences of each member and thus permitted the practice of new activities of research and new practices by the more reticent teachers of the community.

## **FIRST RESULTS OF OUR STUDY**

In this section, we present the first results we think we have obtained as our study is still in progress. These results are about the observed practices, the community of practice and its accompaniment, the pertinence of the design.

### **Observed practices**

The teachers appreciate that we propose them some problems but this does not change substantially their practice in an automatic way. Following our analysis, the problems proposed are still open when they are given to the pupils. The difficulties within the observed practices of the teachers seem to appear more during the phase of exchanges between the pupils and the teacher and during the management of the debates that emerge in the lessons. Another point is that generally the teachers do not hesitate now to plan two or three lessons for the same problem as they planned only one lesson at the beginning. Even more, some teachers address some parts of the syllabus that they did not address before. A side effect is that teachers notice that the pupils are more involved during the lessons even the more “traditional” ones.

A possible bias for that result that we have to take into account in the analysis is the fact that as we observe directly several lessons, the teachers are, in a certain way, forced to practice these new activities more than once a year.

### **The community of practice**

We have created a community of practice with the teachers and this is in our opinion attested by their implication even if this experiment is out of their normal professional duty. It is a major result when one takes into account an element of the social component which is that these teachers consider as important the time devoted to their professional activity and also its output.

The other important result is about the implication of the teachers in the community. The teachers are always motivated even if we do not judge or assess the relevance of their practice and because it is a free activity. They could be deceived by this strange behaviour from a teacher educator like us. This is due to the activity of the community and to its accompaniment as the teachers are not alone to experience with the same problems. Even if they choose the same problems asynchronously, it permits us to take risks with their pupils. We find several references in the discourses to the experiences of each others that favour choices even if they were announced as inconceivable before. The “pioneers” make the “novices” feel more confident during the meetings when they speak about their own experience about a specific problem or about a more general aspect. We note that, contrary to our hypothesis, we find just a few references to the old reports in the community. In particular the “novices” do not ask to see the old reports or even for information about the previous meetings. The “novices” are more interested in the discussions within the peers during the meetings as soon as they join the community.

The management of the leadership in the group must be shared and we see it as being very important. For example, we found that the lack of specific vocabulary and of common understanding about the management of research activities sometimes hindered communication in the community. Sometimes its members were embarrassed because they could not reach a conclusion amongst themselves. Our own role in structuring the discussion is one of the characteristics of the functioning of the community which we wish to study further. The role of the expert was an emerging issue from the work of WG12 and our own role in the design needs to be more fully characterized to see the impact of our ‘expertise’.

Finally we find in our experiment more evidence of a *minimal* collaborative work instead of an intense collaborative work. We want to insist on this point: perhaps it is enough to enable the teachers to take advantage of a design, to permit the existence of moments of research within the classes.

### **Pertinence of the design**

The teachers appreciate the accessibility of the design. For example, the website is mainly consulted just before the lesson, sometimes in the morning of the lesson. According to our hypothesis, we have chosen to present only a minimal amount of information to the teachers. We notice that no pedagogical information, that could be constituted by our a priori analysis, were asked by the teachers about one chosen problem. Mainly, the questions are more about general things like management of the debates within the classroom. All happens like if the teachers search for acquiring a general behaviour for this kind of mathematical activities, like if the problems had no specificity. The teachers also notice several remarks from the other reports about the reactions of the pupils and they appreciate the “elements for debates” section that we have added on the website at the end of the 2<sup>nd</sup> year of our experiment following my proposition instead of being the target of discussions as we thought *a priori*. In

contrast to what we thought, our regular questions about the enhancement expected by the members always received the same kind of answers: “Don't change anything!”. Facing the difficulties encountered by the teachers during their lessons with the problems of the website and the discussions about the management of these lessons – difficulties like “what can be done when a pupil's answer seems to be correct if the teacher is not sure of its validity or if the pupils do not find the complete answer at the end of two lessons – we have finally proposed this section. The teachers agreed under the condition to be as easy to consult as the existent website. The comments proposed, as it stays simple and easy to consult, is seen as useful by the teachers to anticipate certain situations or simply not to feel too surprised in situation. We think that the teachers search the keys of this kind of situation, they want a good return of the information consulted and of the duration of the consultation. Another example of the accessibility aspect is that, even if the teachers have a big interest for the reports and give contextualised examples of this interest, it appears that this modality is too expensive to be regular. There are only a few reports written even if the teachers are implied when the community discuss about the modalities of the reports. We conclude that the time is an important factor to explain this fact as they said that writing a report takes approximatively two hours. Nevertheless, the simple existence of the report modality stays as a tool of personal reflection for the teachers about their professional activity and they appreciate that. We think that, never rejected, it constitutes an engine of the community.

The reports and even the simple anticipation of their writing have often permitted the teachers to have a different vision on their own practice and their implication in the mediation (mediation component) they used with their pupils. For example, it is simply the awareness to have given more or less the solution to the pupils or to have more or less excluded some pupils' propositions finally interesting. Here again, we point out the articulation between the two main frames of our work. Our vision through the filter of the mediation component permits us to identify elements of the practice and at the same time to make emerge (by the means of the reports, during the meetings) some focus points of the community and thus to accompany its functioning. Here, reports are reifications in the Wenger's meaning that are useful for the community: the reports, written or not, sent or not, exist within the community and help it to think, to discuss, about practice. We have introduced a boundary-object in the community, it has become another thing, a reification of the community.

## **CONCLUSION AND DISCUSSION**

The design that we proposed was greatly appreciated by the teachers and this result highlights our hypothesis about the accessibility of the resources for the teachers and the interest in using the theory of communities of practice. If we associate this fact with the time factor, an element of the social component evoked several times by the teachers, we infer that there is a major obstacle to the exploitation of existing resources. The density of the text, the distance from existing practices, the energy



required for a change of practice are too great for us to expect that practices can evolve on their own. The teachers need a 'facilitator' and specific concern for the accessibility of the resources to support them in trying to change their practice. To achieve the goals of this project and in particular to model the possible role that the experts could play when they work with the teachers, the concept of community of practice is thus particularly useful as it gives us some interesting concepts such as boundary-object and reification to think of the design and to manage the community with regards to existing practices. This approach is also of great interest managing collaborative communities that could welcome novice teachers sometimes more accustomed to this way of working.

## REFERENCES

- Arsac, G., Germain, G., Mante, M.: 1991, 'Problème ouvert et situation problème' IREM de Lyon.
- Assude, T., Gélis, J.M.: 2002, 'Dialectique ancien-nouveau dans l'intégration de cabri-géomètre à l'école primaire', *Educational Studies in Mathematics* 50, 259–287.
- Chevallard, Y.: 1999, 'L'analyse des pratiques enseignantes en théorie anthropologique du didactique', *Recherche en didactique des mathématiques* 19, 221-266.
- Coppe, S., Houdement, C.: 2002, 'Réflexions sur les activités concernant la résolution de problèmes à l'école primaire', *Grand N* 69, 53-62.
- Graven, M.: 2004, 'Investigating mathematics teacher learning within an in-service community of practice: the centrality of confidence', *Educational Studies in Mathematics* 57, 177-211.
- Jaworski, B.: 2003, 'Research Practice Into/Influencing Mathematics Teaching and Learning Development: Towards a Theoretical Framework Based on Co-Learning Partnerships', *Educational Studies in Mathematics* 54, 249-282.
- Lenfant, A.: 2001, From a student institutional position to a teacher one : what changes in the relationship to algebra. *Proceedings of PME 25*, vol .3, 297-304. University of Utrecht
- Robert, A., Rogalski, J.: 2005,. 'A Cross-Analysis of the Mathematics Teacher's Activity. an example in a French 10th-grade Class', *Educational Studies in Mathematics* 59, 269-298.
- Roditi, E.: 2001, L'enseignement de la multiplication des décimaux en sixième, Études de pratiques ordinaires. PhD Thesis, Université de Paris 7.
- Wenger, E.: 1998, *Communities of Practice, Learning, Meaning and Identity*, Cambridge University Press.

## ADAPTING THE HYPOTHETICAL LEARNING TRAJECTORY NOTION TO SECONDARY PRESERVICE TEACHER TRAINING

Pedro Gómez<sup>a</sup>, María José González<sup>b</sup> and Jose Luis Lupiáñez<sup>a</sup>

<sup>a</sup>Universidad de Granada, <sup>b</sup>Universidad de Cantabria (Spain)

*We adapt the idea of hypothetical learning trajectory (Simon, 1995) to preservice teacher training. Our approach is based on the notion of capacity, which is used to characterize a concrete teacher's learning goal. Using links between capacities, we propose some tools that can be used by a teacher to analyze and select tasks and to produce hypotheses about students' learning processes. We describe possible uses of these tools by future teachers, considering that they will use standard available resources in preservice teacher training: meanings of a concept in school mathematics and students difficulties when facing the tasks. We exemplify this process considering a particular learning goal in a lesson on the quadratic function.*

### INTRODUCTION

When a teacher plans mathematical tasks he carries out some kind of anticipation about his students' learning processes. This can be considered one basic assumption for any of the teachers' planning responsibilities, from the annual subject design to the planning of every daily class period. When this anticipation has to be made with the purpose of designing mathematical tasks in a constructivist framework, it is highlighted the so-called *planning paradox* (Ainley & Pratt, 2002, p. 18). This paradox points out the tension between impoverished mathematical tasks, focused on learning goals, in opposition to students' engaging tasks that, however, imply difficult learning assessment. Simon (1995) tackled this paradox by introducing a particular view of the teacher planning process in a constructivist framework. He elaborated on the notion of *hypothetical learning trajectory* (HLT), which has gone through different interpretations and elaborations (see, for example, Clements & Sarama, 2004 for an overview).

In this paper we address the question of anticipating students' learning processes by focusing in the initial phase of the teacher professional development. In this context, we propose some tools that can be used by a future teacher to produce hypotheses about students' learning processes and to analyze and select tasks. These tools are supported on the notion of *capacity*. We use this term to refer to the successful performance of an individual with respect to a given task. Using this notion we give a concrete meaning to the notion of teacher's *learning goal*: it becomes characterized by a set of sequences of capacities, that is, by a set of *learning paths of tasks*.

The first section of this paper is devoted to present the theoretical framework of the work. In the second section we describe our basic notions: the learning goal and its related capacities. Then, in the third section, we describe the notion of learning path of a task, which can be used with a practical purpose by a teacher to reflect on and to be able to justify his decisions concerning the analysis and selection of mathematical

tasks. In this section, we present some other associated tools to serve for this purpose. In the fourth section, we describe how the future teacher can use these tools, based on previously identified school mathematics meanings of a topic and students' difficulties when solving types of tasks corresponding to the learning goal. Thus, we give an account of the utility of this instrument for the teacher's prevision about the students' learning processes. All these ideas are exemplified considering a preservice teacher planning a lesson on the quadratic function. We finish the paper presenting some remarks on the previous process, addressing its role in the framework of a teachers training course and suggesting some future work.

## THEORETICAL FRAMEWORK

Trying to resolve the planning paradox, Simon (1995) introduced the *hypothetical learning trajectory* (HLT) construct in order to structure the cyclic relationships between the teacher goal for the students learning, the mathematical tasks proposed and the hypotheses about the students' learning. This construct has been widely analyzed. Considering the researchers' viewpoint, the literature shows different HLT's developments, which have been produced by focusing on particular aspects of the notion. These analyses have been framed on a variety of educational domains (curriculum, learning, instruction). But the fact of considering a teacher—and not a researcher—producing his own planning under the previous foundations deserves an adaptation to this particular professional context. Besides, the teacher does not need fixed instructional sequences, but some framework of reference, together with a set of exemplary activities that serve as source of inspiration for his own designs (Gravemeijer, 2004). Teacher knowledge and experience and the literature available to him are the basic resources for the teacher in order to generate HLT's that support his own daily planning task. This information needs to be organized in some systematic process and require to be supported by some specific tools to serve to a concrete teacher planning purpose.

Focusing on the initial teacher training' phase, we use the notion of *curriculum organizers* to refer to conceptual and methodological tools that allow the future teacher to provide specific meaning to the curriculum design of a particular mathematical structure (Gómez & Rico, 2004). Curriculum organizers -such as representations, errors or historical analysis, among others- are structured in a process called Didactical Analysis (Gómez & Rico, 2002) which is conceived as a tool for the future teacher to produce a local curriculum design. Part of this process consists of selecting a teacher learning goal (Farrell & Farmer, 1988; DeLong & Winter, 2001) and transforming it in a sequence of classroom tasks with the corresponding prevision of their impact on the students learning. Our purpose here is to describe the technical components of the curriculum organizer called the *learning paths of a goal* involved in this process. It can be seen as an operational view of an HLT in teacher training courses.

## LEARNING GOAL AND CAPACITIES

Conceptual learning goals of mathematical lessons are usually stated in terms of something that the teacher intends to do and the mathematical content area (Farrell and Farmer, 1988). There is no mention of the students, although the teacher can show a set of tasks that can confirm if the student has developed that goal. The conceptual feature is related to the use of connected knowing along particular networks given in various representation forms (Haapasalo & Kadjevich, 2000; Mousley, 2004). From the students' side, we assume, in concordance with Piaget developments, that knowledge is assimilated in the students' previous schemes, enlarging the network of connected knowledge. From the different approaches that can be followed to determine the tasks involved in instruction in the previous framework, we assume an approach in which students develop a 'procedural oriented' phase that is useful for the development and effective use of conceptual knowledge (Davis et al, 2000). The notion of capacity, that we introduce next, is the basic procedural component whose appropriate coordination when the student solve the proposed tasks, allows him to develop the connected knowledge expressed in a conceptual learning goal.

In the context of school mathematics we use the term *capacity* to refer to the successful performance of an individual with respect to a given and concrete task. Therefore, we will say that an individual has developed a capacity when he is able to solve the tasks requiring it. For instance, we will say that an individual has developed his capacity for completing squares when he successfully solves this concrete task. Capacities are specific to singular mathematical topics, are bound to types of tasks and are linked to observable student behaviours. A capacity depends on the current knowledge of the individuals it refers to. In a planning context for upper secondary mathematics, a teacher can formulate "completing the square" as a capacity if he considers that students of this level should know the procedures for solving tasks requiring it. For lower secondary students, the teacher might set "completing the square" as a learning goal.

A conceptual learning goal is the framework of reference that delimits and conditions the procedures that the teacher is expected to perform in order to formulate his hypotheses about the process of the students' learning. If the teacher wants to design tasks for promoting his students' achievement of that goal, then it is necessary to characterize the goal in terms of the capacities required to succeed when performing those tasks. The core of this paper deals with the relationship established between a learning goal and their corresponding capacities.

### An example

Let us assume that the teacher is planning a lesson on the quadratic function for upper secondary mathematics students and that he has chosen the following learning goal:

*LG: To recognize and use the graphical meaning of the parameters of the symbolic forms of the quadratic function and communicate and justify the results of its use.*

A concrete learning goal does not refer to the quadratic function as a whole. Figure 1 shows a partial result of the quadratic function subject matter analysis involving only two symbolic forms and some of the graphical elements of the parabola (Carulla & Gómez, 2001).

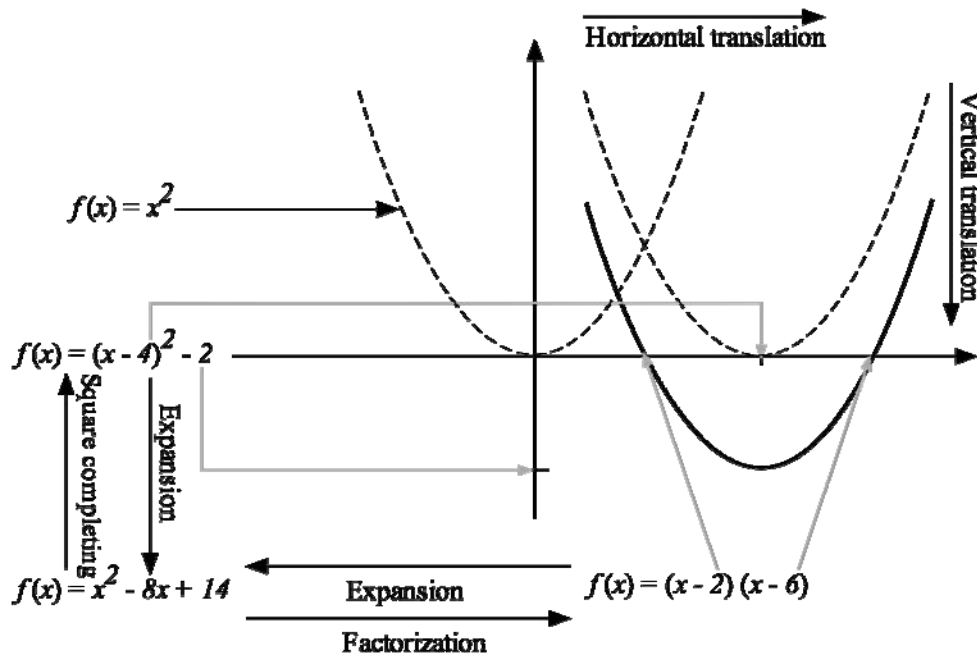

Figure 1. Partial result of a subject matter analysis

On the basis of the information outlined in Figure 1, the teacher can identify some of the capacities involved in this topic. Table 1 shows such a list. They have been obtained and classified taking into account the kind of representation involved (symbolic, graphical).

<i>Perform, communicate and justify symbolic transformation procedures</i>	<i>Identify, show and justify graphical elements</i>
C1 Square completion	C8 Vertex coordinates
C2 Expansion	C9 Y-axis intersections
C3 Factorization	C10 X-axis intersections
	C11 Focus coordinates
	C12 Directrix equation
	C13 Symmetry axis equation
<i>Identify, show and justify symbolic elements</i>	<i>Perform, communicate and justify graphical transformation procedures</i>
C4 Canonical form (a, h, k)	C14 Horizontal translation
C5 Focus form (p, h, k)	C15 Vertical translation
C6 Standard form (a, b, c)	
C7 Multiplicative form (a, r <sub>1</sub> , r <sub>2</sub> )	C16 Vertical scaling

Table 1: Capacities for the considered learning goal

## LEARNING PATHS

We introduce the idea of *learning path of a task* as a sequence of capacities that students might put in place in order to solve it. For instance, for the task  $T_I$ : “given that 2 and 6 are the X-intercepts of a parabola with  $a = 1$ , find the coordinates of its vertex”, a learning path is the sequence  $C_{10} \rightarrow C_7 \rightarrow C_2 \rightarrow C_6 \rightarrow C_1 \rightarrow C_4 \rightarrow C_8$ . Learning paths can be displayed graphically. If we group capacities according to Table 1, then the above sequence can be displayed as shown in Figure 2: recognize the X-axis intersections as a graphical element ( $C_{10}$ ), recognize that those intersections correspond the values of  $r_1$  and  $r_2$  in the multiplicative form of the quadratic function ( $C_7$ ), use the expansion procedure ( $C_2$ ) in order to obtain the standard form and recognize it ( $C_6$ ), use the square completion procedure ( $C_1$ ) in order to obtain the canonical form and identify and recognize its parameters  $h$  and  $k$  ( $C_4$ ), and recognize the values of those parameters as the coordinates of the vertex in the graphical representation ( $C_8$ ).

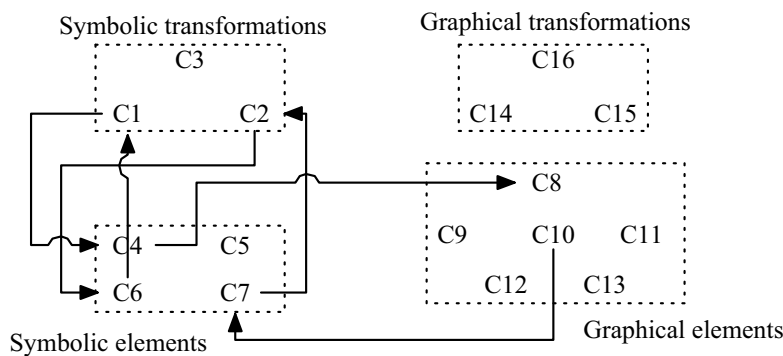

**Figure 2: A learning path for a task  $T_I$**

A learning path for a task, such as the one depicted in Figure 2, informs the teacher about an *ideal* sequence of capacities that the students might execute when facing the task. It is ideal in the sense that it emerges from the task and the school mathematics meanings of the subject matter related to the learning goal, under the assumption of the students' previous knowledge (each  $C_i$  in the learning path is a capacity, as defined previously). It does not take into account, for the time being, the difficulties that the students might have when trying to solve the task or alternative sequences of capacities that they might execute and that do not correspond to the learning goal's subject matter.

From this ideal perspective, we can talk of the learning paths of a goal. For that purpose, the teacher can identify and characterize the set of tasks,  $T$ , whose successful solution distinguishes, in his opinion, an individual that has achieved the learning goal. The *learning paths of a goal* are those that correspond to the tasks in  $T$ . It is confusing to represent the graph of the learning paths of a goal. In Table 2 we depict the links between capacities that can be established on the basis of the school mathematics meanings of the learning goal's topic. A “1” in a cell indicates that it is possible to link the capacity in that row with the capacity in the corresponding column. The learning paths for a goal, from this ideal perspective, are the sequences

of capacities that can be constructed from the information in the table. For instance,  $C8 \rightarrow C4 \rightarrow C2 \rightarrow C6$  is a learning path for  $LG$ . Learning paths inform the teacher about the tasks that he can consider when planning a lesson for a given learning goal. A task is established by the information required for executing the first capacity in the learning path (the information given by the task) and the information required for the last capacity in the path (the information asked for by the task). A *type of task* can be characterized by the learning paths required for the solution of the tasks composing it.

	C1	C2	C3	C4	C5	C6	C7	C8	C9	C10	C11	C12	C13	C14	C15	C16
C1	0	0	0	1	1	0	0	0	0	0	0	0	0	0	0	0
C2	0	0	0	0	0	1	0	0	0	0	0	0	0	0	0	0
C3	0	0	0	0	0	0	1	0	0	0	0	0	0	0	0	0
C4	0	1	0	0	0	0	0	1	0	0	0	0	0	1	1	1
C5	0	1	0	0	0	0	0	0	0	0	1	1	1	0	0	0
C6	1	0	1	0	0	0	0	0	1	0	0	0	0	0	1	1
C7	0	1	0	0	0	0	0	0	1	0	0	0	0	0	0	0
C8	0	0	0	1	0	0	0	0	0	0	0	0	0	1	1	0
C9	0	0	0	0	0	1	0	0	0	0	0	0	0	0	0	0
C10	0	0	0	0	0	0	1	0	0	0	0	0	0	0	0	0
C11	0	0	0	0	1	0	0	0	0	0	0	0	0	0	0	0
C12	0	0	0	0	1	0	0	0	0	0	0	0	0	0	0	0
C13	0	0	0	0	1	0	0	0	0	0	0	0	0	0	0	0
C14	0	0	0	1	0	0	0	1	0	0	0	0	0	0	0	0
C15	0	0	0	1	0	1	0	1	0	0	0	0	0	0	0	0
C16	0	0	0	1	0	1	0	0	0	0	0	0	0	0	0	0

**Table 2: Possible links among capacities for the learning goal  $LG$**

A learning goal can be made explicit with the help of its learning paths. A learning path is more than the capacities that constitute it: it is the sequence of capacities with which it is possible to solve a certain type of tasks. Therefore, an individual has achieved a goal if, for the type of tasks that characterize it, he is able to recognize the learning path that corresponds to each type of task and to execute them successfully.

The teacher can use the information in Table 2 as a reference for identifying, analyzing and comparing the learning paths associated to different tasks. For instance, he can take into account the number of capacities involved and whether he considers the sequences challenging to his students. He can also dynamically use this tool in order to adapt learning sequences to students or to select and design tasks.

The teacher has to take into account the difficulties his students might have when facing the tasks. Difficulties refer to sequences of capacities that the students do not recognize or are not able to execute. For instance, he might know, by experience or from the literature, that students tend to recognize only two symbolic forms of the quadratic function. He can include this information in his analysis of the goal's learning paths by, for instance, marking capacities C4 and C5 and their links in Table 2. He should then favour those tasks whose learning paths involve those capacities and those links. On the other hand, the teacher might know that, for certain tasks, his

students use sequences of capacities that do not correspond to the subject matter that he has delimited for the learning goal. For instance, the students might use numerical procedures for producing the graph of the function and, then, estimate the value of some of its elements. In this case, the teacher has to enlarge the subject matter analysis and reformulate the goal's capacities and learning paths in order to take into account these difficulties.

A learning goal's learning paths can be used for analyzing and selecting tasks (and sequences of tasks). For instance, the teacher might decide that the learning path for task  $T_1$  involves too few capacities and he might find a task that he considers can be more challenging for the students. He might use the task  $T_2$ : “given a parabola with focus at  $(0, \frac{9}{4})$ , directrix  $y = \frac{7}{4}$ , and that can be obtained with a vertical translation of two units from  $y = x^2$ , find the coordinates of its vertex, its intersections with the X and Y axes, its symmetry axis and its symbolic forms. Justify your results”. Figure 3 shows the learning paths for this task.

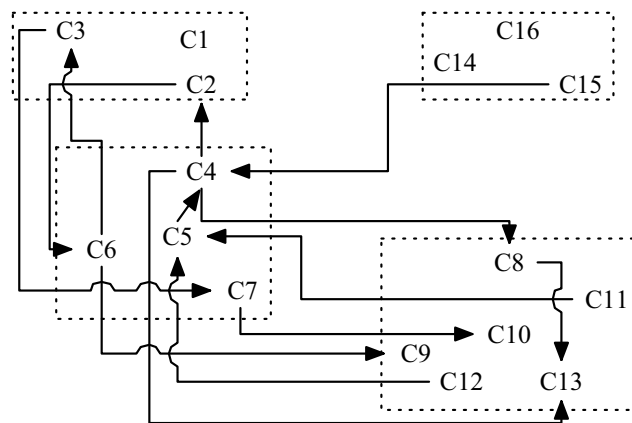

**Figure 3: Learning paths for the second task**

On the basis of the information in Figure 3, the teacher might consider that task  $T_2$  might better contribute to the goal achievement. He might even consider that he can combine  $T_2$  with other similar tasks with different initial data (Gómez, Mesa, Carulla, Gómez & Valero, 1996, pp. 77-79). In this sense, tasks' analysis on the basis of the goal's learning paths provides the teacher with information that he can use for comparing and selecting tasks, and for designing sequences of tasks that can contribute to the learning goal achievement.

### **LEARNING PATHS IN PRESERVICE TEACHER TRAINING**

The design of preservice teacher training courses should be based on a conceptualization of the activities that the teacher has to do in order to promote students' learning and of the knowledge that is necessary to perform those activities. We call the structuring of a cycle of these activities a didactical analysis (Gómez & Rico, 2002). It is organized around four analyses: subject matter, cognitive, instruction, and performance. Didactical analysis allows the teacher to examine and



describe the complexity and multiple meanings of the subject matter, and to design, select, implement, and assess teaching/learning activities.

Any cycle of the didactical analysis begins with the identification of students' knowledge for the subject matter at hand on the basis of the information provided by the last phase of the previous cycle. With this information, and taking into account the global planning of the course, we expect the preservice teacher to make a proposal for the goals he wants to achieve and the mathematics content he wants to work on. The next step of the cycle involves the description of the mathematical content from the viewpoint of its teaching and learning in school. The subject matter analysis is a procedure that allows the preservice teacher to identify and organize the multiple meanings of a mathematical topic. It is based on three aspects of any given topic: its representations, conceptual structure and phenomenology (Gómez, 2006). The preservice teacher can use this information in the cognitive analysis, in which he establishes his hypothesis about how students construct their knowledge when they face the learning activities that are proposed to them. The information from the subject matter and cognitive analysis allows the teacher to carry out an instruction analysis: the analysis, comparison and selection of the tasks that can be used in the design of the teaching and learning activities that will compose the instruction in class. In the performance analysis the teacher observes, describes, and analyzes students' performance in order to produce better descriptions of their current knowledge and review the planning in order to start a new cycle.

The learning path of a task can be used as a pivotal notion in the cognitive and instruction analysis. Preservice teachers in a methods course can use the information from the subject matter analysis of the topic in order to identify and formulate the capacities related to a given learning goal and to establish an adjacency matrix for it, as the one shown in Table 2. The information in this matrix enables the preservice teacher to characterize the learning paths of a sequence of tasks, to locate students' difficulties and, therefore, to analyze, compare and select those tasks that, in his opinion, can better promote students' learning goal achievement. With this procedure for the cognitive and instruction analysis, task design is not left to intuition or trial and error. Teachers can make hypothesis about students' learning process when facing the tasks with the help of a systematic analysis of the mathematical topic and of its cognitive implications. Our conjecture is that this type of detailed analysis of a concrete mathematical topic enables preservice teachers to acknowledge the complexity of school mathematics and provides them with tools and procedures that they can use in their future practice.

## **FINAL REMARKS**

We have followed the principles of HLT to propose a procedure that can be used by teachers for planning their instruction—in a systematic and reflective manner—and promoting the achievement, to the extent of their knowledge, of students' learning goals. We have shown that, when analyzed in detail, a concrete learning goal is a complex object: it can be characterized by a numerous set of learning paths. The

question remains of whether there are criteria for selecting the combination of learning paths (and the corresponding sequence of tasks) that can promote students' goal achievement in the most efficient manner.

The notion of learning path and its associated tools and procedures tackles the planning paradox because it allows the teacher to establish an explicit link between learning goals and tasks. Planning is produced on the basis of the relationship between the two. This notion does not give an automatic answer to the issue of which tasks are challenging or relevant. This is a question that teacher has to answer for himself on the basis of his knowledge of his students. However, learning paths allow the teacher to distinguish the universe of tasks he can choose from and to analyze those tasks in terms of the activity that his students might get involved in when solving them.

Future teachers performing cognitive and instruction analysis are involved in other issues, besides the analysis of a learning goal and a task learning paths, for the purpose of selecting tasks and foreseeing students' learning (Gómez, 2006). These analysis deal as well with procedures for identifying and formulating learning goals for a topic, with how learning goals should be combined when planning the teaching and learning of that topic, and with how tasks should be organized in sequences. Lupiáñez & Rico (2006) have also used the notion of capacity to develop an instrument for assessing the relevance of a learning goal or a task: the extent with which the goal or the task contributes to the development of a given list of competencies. All these processes represent instruments that the future teacher can use for articulating mathematical and learner-centered perspectives when planning tasks in the context of a learning goal.

## REFERENCES

- Ainley, J. and Pratt, D.: 2002, 'Purpose and utility in pedagogical task design', in A. Cockburn and E. Nardo (eds.), *Proceedings of the Twenty Sixth Annual Conference of the International Group for the Psychology of Mathematics Education*, Vol. 2, pp. 17–24. Norwich, UK: School of Education and Professional Development, University of East Anglia.
- Carulla, C. and Gómez, P.: 2001, 'Mathematics teachers didactical development and the quadratic function', in M. van den Heuvel-Panhuizen (eds.), *Proceedings of the 25th Conference of the International Group for the Psychology of Mathematics Education*, Utrecht, Freudenthal Institute, p. 1-391.
- Clements, D. H. and Sarama, J.: 2004, 'Learning trajectories in mathematics education', *Mathematical Thinking and Learning* 6 (2), 81-89.
- Davis, G., Gray, E., Simpson, A., Tall, D. and Thomas, M.: 2000, 'What is the object of the encapsulation of a process'. *Journal of Mathematical Behavior* 18(2),223-241.

- DeLong, M. and Winter D.: 2001, 'An Objective Approach to Student-Centered Instruction'. *PRIMUS*, XI(1): 27-52.
- Farrell, M. A. and W. A. Farmer.: 1988, *Secondary Mathematics Instruction: An Integrated Approach*. Providence, RI: Janson.
- Gómez, P. and Rico, L.: 2002, 'Didactical analysis and planning of school tasks in preservice mathematics teacher training', in D. S. Mewborn, White, D. Y. White, H. G. Wiegel, R. L. Bryant and K. Nooney (eds.), *Proceedings of the twenty-fourth annual meeting of the North American Chapter of the International Group for the Psychology of Mathematics Education (Vol. 3)* (pp. 1214-1217), ERIC Clearinghouse for Science, Mathematics, and Environmental Education, Columbus, OH.
- Gómez, P. and Rico, L.: 2004, 'Integration of didactical knowledge and mathematical content knowledge in pre-service teacher training'. Paper presented at the Discussion group "*The Education of mathematics teachers*" of the 10th International Congress on Mathematical Education, Copenhagen.
- Gómez, P., Mesa, V. M., Carulla, C., Gómez, C. and Valero, P. (Eds.): 1996, *Situaciones problemáticas de precálculo. El estudio de funciones a través de la exploración con calculadoras gráficas*, Una Empresa Docente y Grupo Editorial Iberoamérica, México.
- Gómez, P.: 2006, 'Análisis didáctico en la formación inicial de profesores de matemáticas de secundaria', in P. Bolea, M. J. González and M. Moreno (eds.), *X Simposio de la Sociedad Española de Investigación en Educación Matemática*, pp. 15-35, Instituto de Estudios Aragoneses, Huesca.
- Haasapalo, L. and Kadjevich, Dj.: 2000, 'Two Types of Mathematical Knowledge and Their Relation', *Journal. für Mathematik-Didaktik* 21 (2), 139-157.
- Gravemeijer, K.: 2004, 'Local instruction theories as means of support for teachers in reform mathematics education', *Mathematical Thinking and Learning* 6 (2), 105-128.
- Lupiáñez, J. L. and Rico, L.: 2006, 'Análisis didáctico y formación inicial de profesores: competencias y capacidades en el aprendizaje de los escolares', in P. Bolea, M. J. González and M. Moreno (eds.), *X Simposio de la Sociedad Española de Investigación en Educación Matemática*, pp. 225-236, Instituto de Estudios Aragoneses, Huesca.
- Mousley J.: 2004, 'An aspect of mathematical understanding: the notion of 'connected knowing'', in M.J. Hoines and A.B. Fuglestad (eds.), *Proceedings of the 28th Conference of the International Group for the Psychology of Mathematics Education*, Vol. 3, pp. 377-384.
- Simon, M.: 1995, 'Reconstructing mathematics pedagogy from a constructivist perspective', *Journal for Research in Mathematics Education* 26 (2), 114-145.

# **FORMATIVE ASSESSMENT: TOOLS FOR TRANSFORMING SCHOOL MATHEMATICS TOWARDS A DIALOGIC PRACTICE?**

Jeremy Hodgen

King's College London

*Recent interest in formative assessment in the UK originates in a review by Black and Wiliam (1998). Subsequent widescale dissemination has focused on a series of practitioner-focused publications that distil the research findings simply. By examining one qualitative case study, this paper examines the potential for formative assessment as conveyed through simple messages to transform practices of teaching and learning in school mathematics. The analysis draws on activity theory to examine whether the division of labour in classroom discussion is transformed through the use of formative assessment strategies. Some evidence is found for changed practice during groupwork, but during whole class discussions, the strategies appear to have reinforced existing teacher dominated patterns of talk, allowing little space for pupil voice. Implications for the dissemination of research findings are discussed.*

## **INTRODUCTION**

In this brief paper, my aim is to examine the potential for formative assessment as conveyed through simple messages to transform practices of teaching and learning in school mathematics. My focus is on just one teacher in one classroom, chosen as a “telling case” (Mitchell, 1984), although the data is drawn from a wider study. (See Research Setting and Methodology below.) This teacher had been identified as an exemplary practitioner in formative assessment, although, as discussed below, the actual practice of formative assessment in her classroom was rather mixed.

## **FORMATIVE ASSESSMENT IN THE UK**

The recent interest in formative assessment, in the UK at least, originates in a substantial review of its effectiveness by Black and Wiliam (1998a). In this, they describe the broad characteristics of formative assessment as including the use of rich and challenging tasks, a high quality of classroom discourse and questioning, feedback and the use of self and peer assessment. In particular, they argue that “the quality of the interaction [between pupil and teacher] ... is at the heart of pedagogy” (p.16). Subsequent to this review, the Assessment for Learning Group at King's College London investigated the specifics of formative assessment in a collaborative project with a group of teachers (Black, Harrison, Lee, Marshall, and Wiliam, 2003). The findings of this programme of research have been disseminated through a series of short pamphlets distilling the research findings in a simple format and aimed at a professional audience (Black, Harrison, Lee, Marshall, and Wiliam, 2002; Black and Wiliam, 1998b; Hodgen and Wiliam, 2006). These ideas have been extremely influential in UK schools [1] and now form a key aspect of government policy [2].

But the specific nature of formative assessment remains rather vague. Black and Wiliam (2006) have described formative assessment as a “trojan horse” with which to effect a transformation of teaching into a more dialogic pedagogy (Alexander, 2004). Others suggest that this lofty aim may be rather far from the reality and that the approach may often be being misunderstood rather simplistically as a set of straightforward techniques. In a study of one school, Smith and Gorard (2005) found that teachers were simply operationalising the notion of “comment-only marking”, a strategy of giving high quality feedback to students without grades [3], purely in terms of reporting no grades in feedback to pupils. In a study of 27 teachers drawn from a larger longitudinal research project, Marshall and Drummond (2006) found that most teachers interpreted (and enacted) formative assessment simply as a set of techniques. The few teachers in their study, who went beyond this to implement the spirit of formative assessment, associated the approach with increased learner autonomy.

The teacher, whom I focus on in this paper, had had no direct contact with the Assessment for Learning group at King’s College London except through publications and possibly lectures. Hence, her case provides an opportunity to begin to examine this wider dissemination process and how the messages about formative assessment interact with existing classroom practice.

## **THEORETICAL FRAMEWORK**

### **Formative Assessment: Tools to promote high quality discourse**

My emphasis here is on discourse, dialogue and the quality of classroom talk. The Assessment for Learning literature emphasises two strategies in particular: rich, high order questions, and wait time (Black, Harrison, Lee, Marshall, and Wiliam, 2002). These strategies are both complex.

Much classroom discourse consists largely of what Bloom (1956) terms low-level questions for which the teacher knows the answer (e.g., asking pupils to recall facts and procedures.) Generally, increasing the proportion of higher-level questions is associated with increases in pupil performance (Burton, Niles, Lalik, and Reed, 1986). But the situation is a complex one. Simply asking more higher-level questions in itself does not shift the balance of classroom dialogue away from a teacher-dominated initiation, response, feedback, or IRF, pattern (Sinclair and Coulthard, 1975) toward one in which pupils are active participants. Davis (1997) suggests that one aspect of this is that teachers need to listen more interpretively, listening to pupils’ contributions in order to work out why they respond in particular.

The wait time, the time a teacher pauses after asking a question, is typically less than 1 second in mathematics classrooms. Increasing wait time to around 3 seconds can have very dramatic effects on the involvement of students in classroom discussion, particularly in relation to higher-order questions (Askew and Wiliam, 1995). But

solely increasing wait time to more than about 5 seconds can actually decrease the quality of classroom talk (Tobin, 1986).

### **Professional Development in School Mathematics**

The original collaborative research project with teachers from which many of the techniques and strategies are drawn took place over two years and involved regular discussions and teaching with academics from the King's Assessment for Learning Group (Black, Harrison, Lee, Marshall, and Wiliam, 2003). The wider dissemination has largely through publications, lectures and short day seminars. In addition, schools have been issued with training materials (DfES, 2004). The literature on teachers' professional education and learning would lead us to be sceptical that reduced programme of intervention can lead to widespread significant change (Clarke, 1994). Spillane (1999), for example, argues that, for change to take place, teachers need to be involved in professional networks and sustained discussions with experts in addition to access to high quality teaching materials. Nevertheless, in the UK, there is currently a great deal of interest in school-led and teacher-led professional development, particularly focused around teachers' engagement with research (Burghes, 2005).

### **Classroom dialogue and the division of labour**

Alexander (2004) describes the role of dialogue in learning as follows:

In the narrower context of that classroom talk through which educational meanings are most characteristically conveyed and explored, dialogue becomes not just a feature of learning, but one of its most essential tools. Hence we may need to accept that the child's answer can never be the end of a learning exchange (as in many classrooms it all too readily tends to be) but its true centre of gravity. (p.14)

This view of the classroom dialogue is one in which pupils have a much more active and involved role. This is an approach to teaching that provides space for pupils' voices to express doubt, dissent, interest, disinterest as well as their own mathematical ideas (Amit and Fried, 2005). Thus, as Black and Wiliam (2006) argue, the "trojan horse" at the heart of the formative assessment project is concerned with transforming the *division of labour* in the classroom.

In the analysis of this lesson, I focus on the activity system (Engeström, Miettinen, and Punamaki, 1999). In order to address my aim, I examine the extent to which the *tools* of formative assessment (e.g., wait time, higher-level questions, challenging tasks) act as *mediating means* (Askew, Forthcoming) to enable this teacher to effect a shift in the *rules* of the classroom (e.g., dominant patterns of discourse such as IRF) and to effect changes to the division of labour in the classroom (e.g., providing more space for pupils' voices.)

## **THE CONTEXT: SECONDARY SCHOOL MATHEMATICS IN ENGLAND**

School mathematics in England takes place within a tightly regulated and rigidly structured environment. In addition to a statutory National Curriculum and a regular school inspection regime, there is detailed guidance on mathematics pedagogy and content through the Framework for Teaching Mathematics at Key Stage 3 (DfEE, 2001) [4]. This Framework breaks school mathematics down into a vast array of concepts thus presenting a fragmentary picture of the discipline. One effect of this is that many teachers view the mathematics curriculum as overloaded (Barnes, Venkatakrisnan, and Brown, 2003). Hence, in order to cover the curriculum, many teachers feel under pressure to teach lessons at a fast pace. A further feature of English secondary mathematics classrooms is the use of ability grouping: pupils are grouped in heterogeneous sets according to their ability in mathematics (Hodgen, Forthcoming). Boaler, Wiliam and Brown (2000) argue that high ability classes tend to be conducted at a faster pace than other classes.

## **RESEARCH SETTING AND METHODS**

The mathematics lesson discussed in this paper was video recorded as data for the Questioning, Dialogue and Assessment for Learning Video project funded by the Department for Education and Skills (DfES) over 8 months in 2004. The aim of the project was to investigate the relationship between questioning, dialogue and formative assessment. A secondary objective was to investigate the differences and similarities in formative assessment practices in different subjects (Hodgen and Marshall, 2005).

The project involved 10 Local Authorities in England. Each LA selected one secondary school and two teachers, who were identified by the LA Assessment Advisors in conjunction with school Assessment Co-ordinators as exemplary formative assessment practitioners. Each teacher taught two lessons specifically planned to illustrate the ways in which they used assessment for learning in their classroom, particularly in relation to questioning and dialogue. The teachers were free to choose the lesson topic and class group.

We note that these teachers were unusual in that they were chosen to demonstrate the possibilities for formative assessment. Somewhat surprisingly, given the choice of teachers, the incidence of formative assessment was relatively limited. All the lessons involved the use of techniques associated with formative assessment. Yet less than a quarter of the lessons contained the rich dialogue described by Alexander (2004) and similar to that developed by teachers in the earlier collaborative project (Black, Harrison, Lee, Marshall, and Wiliam, 2003).

The mathematics lesson that we discuss was recorded using three video cameras: one fixed camera directed at the front of the class and two roving hand-held cameras. The teacher provided brief written reflections on the lesson in general and her assessment aims, but we did not have any opportunity to directly discuss the lesson with the

teacher or the pupils. Data analysis of the videos was conducted by a team of researchers at King's College London, which comprised the author together with Paul Black, Christine Harrison and Bethan Marshall. The lessons were summarised, partially transcribed and analysed using techniques previously used by the team and other colleagues (Black, Harrison, Lee, Marshall, and Wiliam, 2003) and drawing on Kvale's (1996) social constructivist approach.

## THE LESSON

This lesson was with a high-ability class of 30 Year 8 pupils. The lesson was focused on linear equations and their graphs and was the second in a connected sequence of two lesson, both of which had been recorded for the project. In her brief lesson commentary, the teacher highlighted the formative assessment strategies of "questioning and wait-time" and "challenging activities". The lesson consisted of four episodes as follows:

*Introduction* (4 mins): The teacher first asked a question that had been set for homework at the end of the previous lesson: "What does  $y = mx + c$  look like?" One pupil responded: "m is the gradient and c is the y-intercept". She then asked the pupils to represent physically using their arms the graphs of simple linear equations (e.g.,  $y = x$ ;  $y = 2x$ ;  $y = x + 1$ ;  $y = -x$ ) The pupils indicated roughly both the gradient and the y-intercept. The pupils observed each other, discussed and self-corrected their solutions informally. The teacher's exploration of pupils' responses was limited, although she asked one pupil to comment about an (incorrect) gradient, where the student had indicated  $y = 2x$  indicated as less steep than  $y = x$ .

*Activity 1* (21 minutes): The teacher asked pupils to identify equations of linear graphs shown graphically on an interactive whiteboard. The pupils indicated their responses using individual whiteboards holding these up for the teacher and other pupils to see. Again, pupils compared, discussed and self-corrected their responses as they carried out the task. Pupils were encouraged to look for equivalent expressions: "Can anyone write that beginning  $x =$ ?" The activity concluded with a consideration  $x + y = 4$ , an equation the pupils had been asked to think as homework preparation for the lesson. The teacher used some higher order questions (e.g., "What is different about this equation?") The discussion was largely a sequence of teacher questions with pupil responses following an elicitation pattern.

*Activity 2* (28 mins): The pupils were asked to work in groups matching cards on which were written equations and tables of x and y values. The cards included some equivalent forms of equations (e.g.,  $y = 1 - 2x$ ;  $x = \frac{(1-y)}{2}$ ) and some equations for which no tabular form was provided. Hence, some cards could not be matched, whilst other had to be placed in sets of three or more. The pupils then played a memory game matching equations and tabular representations of linear functions. After five minutes of paired work, the teacher added a second task: Individually, write each of



the equations in at least one different way, then swap and mark your partner's work. In the plenary discussion, the teacher focused on three examples, which included  $y = (x-1)/2$  and the alternate (incorrect) equation  $x = 2(y+1)$ .

*Conclusion* (4 mins): Returning to an earlier and satisfactorily answered problem, the teacher asked the pupils to "Think about what we've done. If we've got  $x + y = 4$  or  $y + 2x = 5$ , how are we going to draw it?"

## ANALYSIS

In this lesson there was a very stark contrast between the fast pace of the whole class discussion and a more measured pace during group and paired work. I examine these in turn.

### The dialogue in whole class discussions

The whole class discussions were dominated by teacher questions and the teacher did use some questions that might be described as higher-level. However, these were within a pattern of dialogue largely structured around an IRF model, for example:

Teacher: What does  $y = mx + c$  look like? [No pause]

Pupil:  $m$  is the gradient and  $c$  is the  $y$ -intercept.

Teacher: Good. Now can you show me  $y = x$ ?

This is certainly an abstract question. However, it does not, as it stands, require synthesis or explanation. The speed of the response suggests that the pupil simply knew the answer. Hence, whilst in different circumstances this question might be classed as higher-level, in these circumstances it was not. Asking higher-level questions is not simply a technique, it requires a teacher to listen interpretatively to pupils and frame their questions or comments accordingly (Davis, 1997).

As in the above example, there was little evidence of wait-time. The teacher did pause over questions that no pupils could answer. So, for example, the following series of repeated and reframed questions took over 20 seconds and contained 3 pauses:

Teacher: Is  $y=3x + 3$  the same as  $3x = y - 3$ ? [2 second pause] Is  $y=3x + 3$  the same as  $3x = y - 3$ ? [5 second pause] We're looking  $y=3x + 3$  and  $3x = y - 3$ . Are they the same? [2 second pause] Ok. Let's look on the board.

As I have already noted, the research evidence suggests that wait-time used in this way is likely to reduce the quality of classroom talk. In this case, the pupils contributed little and the teacher herself eventually provided an answer on the board.

The talk in whole class discussions was heavily teacher dominated and almost exclusively limited to Alexander's (2004) lower order categories of rote, recitation and instruction rather than dialogic talk. However, the teacher's commentary strongly

suggests that she thought that she had used wait-time and questioning to introduce elements of formative assessment into the whole class discussions.

### **The dialogue during groupwork**

The pattern of discussion during groupwork was very different: pupils talked more and their responses suggested that they also listened to each other more. In addition, the teacher's interventions did not follow the IRF model. Specifically, at these times in the lesson, the teacher avoided giving direct feedback on pupils' responses, thus not only prompting but also creating space for the pupils themselves to comment on each other's ideas.

A second feature was the teacher's use of artefacts in the construction of tasks. The individual whiteboards allowed pupils to observe each other's ideas, thus providing an opportunity for them to compare, discuss and self-correct their responses. The teacher encouraged this talk by acknowledging and valuing it through comments such as "Have a look around", "I see some disagreement here" and "There's some interesting discussions going on around the classroom." The teacher's strategic use of resources was evident at other points. For example, in Activity 2, the matching task, each group had a different set of equations: no two sets were alike, but each set had some equations in common. This choice of cards maximised the likelihood of contrasting groupings, thus providing an opportunity for disagreement and discussion. The equation,  $y = 3x + 2$ , might be either grouped with  $y = 3x - 1$  or  $y = x + 2$ . Thus, one group might highlight the similar gradient, whilst another might highlight the similar y-intercept. Asking pupils to "insist on a good explanation" in their groups was designed to provide the basis for a class discussion focused on reasoning and generalising rather than simply pattern-spotting.

### **A move towards dialogic teaching?**

One feature of this lesson was the way in which much of the whole class discussion was limited by the fast pace during these parts of the lesson. This fast pace is, as I have already noted, typical of UK mathematics classrooms and is especially pronounced in high-ability classes. This in turn restricted the pupils' freedom to comment and develop each other's mathematical ideas. The tools of questioning and wait-time, despite their transformative intentions, served in part to reinforce the existing traditional classroom practices relating to questioning and discussion.

In contrast, during the paired activity, she observed the pupils far more and intervened far less. As a result her interventions were not only tailored to pupils' needs but also acted as a catalyst for Alexander's dialogue between pupils. This in turn provided opportunities for the pupils to create, or "author", mathematics, thus challenging the existing division of labour (Povey, Burton, Angier, and Boylan, 1999).

Thus, there appears to be some evidence that the division of labour has changed during the groupwork activities. This appears to be largely as a result of a reduction

in the number of the teacher's contributions, a change in the teacher's role towards listening and a use of artefacts that encourage collaboration and sharing amongst pupils. On the other hand, during whole class discussions, the existing division of labour, teacher dominated discussion, appears to have been reinforced by the teacher's use and interpretation of the formative assessment strategies of questioning and wait-time.

## DISCUSSION

In this case, the dissemination of formative assessment by distilling the research findings into simple messages appears to have had mixed results, even though the teacher is a recognised expert practitioner. In particular, two of the key strategies for promoting dialogue, questioning and wait-time, appear to have been seriously misinterpreted by this teacher. It seems likely that in general this dissemination process is even less effective. I note also that the teachers' commentary suggests that she perceived her practice had changed more radically than it had.

The promise of simple messages is that they can be communicated easily, quickly and cheaply on a large scale; the danger is that, as in this case, simple messages are all too easily understood simplistically and the essence lost. This case study suggests that one way forward might be to emphasise more explicitly the importance of listening to pupils alongside the strategies of questioning and wait-time, as this teacher did during the groupwork activities. In addition, the structure of these groupwork activities afforded space for the teacher to listen and, thus, space for pupils' voices.

The availability of research findings in practitioner orientated publications such as Black and Wiliam (1998b) is a crucial factor in facilitating a debate about classroom practice. But, such publications are on their own insufficient. Teachers need space to engage in such debates through professional networks and extended professional development and discussions with academics and others (Spillane, 1999). Without this space for teachers' voices, it seems likely that formative assessment will be enacted more as a set of techniques rather than as a step towards a more dialogic form of teaching.

## NOTES

1. For example, Black and Wiliam (1998b) has sold 50,000 copies, whilst Black, Harrison, Lee, Marshall and Wiliam (2002) has sold 40,000 copies.
2. For example, during the academic year 2005/6, approximately 75% of secondary schools in England chose to focus on formative assessment in a government-funded whole school initiative.
3. Butler (1988) found that comment-only marking (i.e., good quality feedback) to be more effective in terms of student learning than either good quality feedback alongside grades or grades on their own.
4. Key Stage 3 covers the first three years of secondary schooling in England: Year 7 (age 11-12), Year 8 (age 12-13) and Year 9 (age 13-14).

## REFERENCES

Alexander, R. J. (2004). *Towards dialogic teaching: Rethinking classroom talk*. York: Dialogos.

- Amit, M., and Fried, M. N. (2005). Authority and authority relations in mathematics education: A view from an 8th Grade classroom. *Educational Studies in Mathematics*, 58(2), 145-168.
- Askew, M. (Forthcoming). Meaning making in mathematics lessons: Developing our theoretical position. In M. Askew, M. Brown and A. Millett (Eds.), *Learning about number: Interactions and outcomes in primary classrooms*. Dordrecht: Springer.
- Askew, M., and Wiliam, D. (1995). *Recent research in mathematics education*. London: OFSTED.
- Barnes, A., Venkatakrishnan, H., and Brown, M. (2003). *Strategy or straitjacket? Teachers' views on the English and mathematics strands of the Key Stage 3 National Strategy: Final Report*. London: ATL.
- Black, P., Harrison, C., Lee, C., Marshall, B., and Wiliam, D. (2002). *Working inside the black box: Assessment for learning in the classroom*. London: King's College London, Department of Education and Professional Studies.
- Black, P., and Wiliam, D. (2006). Developing a theory of formative assessment. In J. Gardner (Ed.), *Assessment and learning* (pp. 81-100). London: Sage.
- Black, P. J., Harrison, C., Lee, C., Marshall, B., and Wiliam, D. (2003). *Assessment for learning: putting It into practice*. Buckingham: Open University Press.
- Black, P. J., and Wiliam, D. (1998a). Assessment and classroom learning. *Assessment in Education*, 5(1), 7-73.
- Black, P. J., and Wiliam, D. (1998b). *Inside the Black Box: raising standards through classroom assessment*. London: King's College London, School of Education.
- Bloom, B. S. (1956). *Taxonomy of educational objectives*. New York: Longman.
- Boaler, J., Wiliam, D., and Brown, M. (2000). Grouping - disaffection, polarisation and the construction of failure. *British Educational Research Journal*, 26(5), 631-648.
- Burghes, D. (2005). Collaborative Practice Model and Networking for CPD. Retrieved 29th March, 2006, from <http://www.ncetm.org.uk/pdfs/CPD.pdf>
- Burton, J. K., Niles, J. A., Lalik, R. M., and Reed, W. M. (1986). Cognitive capacity engagement during and following interspersed mathemagenic questions. *Journal of Educational Psychology*, 78(2), 147-152.
- Butler, R. (1988). Enhancing and undermining intrinsic motivation: the effects of task-involving and ego-involving evaluation on interest and performance. *British Journal of Educational Psychology*, 58, 1-14.
- Clarke, D. M. (1994). Ten key principles from research for the professional development of mathematics teachers. In D. B. Aichele and A. F. Coxford (Eds.), *Professional development for teachers of mathematics: The 1994 Yearbook of the National Council of Teachers of Mathematics* (pp. 37 - 48). Reston, VA: National Council of Teachers of Mathematics.
- Davis, B. (1997). Listening for differences: An evolving conception of mathematics teaching. *Journal for Research in Mathematics Education*, 28(3), 355-376.

- DfEE. (2001). *Framework for teaching mathematics Years 7, 8 and 9*. London: Department for Education and Employment.
- DfES. (2004). *Assessment for learning: whole school training materials*. London: Department for Education and Skills.
- Engeström, Y., Miettinen, R., and Punamaki, R.-L. (1999). Activity theory and individual and social transformation. In Y. Engeström (Ed.), *Perspectives on activity theory: Learning in doing* (pp. 19-38). Cambridge: Cambridge University Press.
- Hodgen, J. (Forthcoming). Setting streaming and mixed ability teaching. In J. Dilllon and M. Maquire (Eds.), *Becoming a teacher* (3rd ed.). Buckingham: Open University Press.
- Hodgen, J., and Marshall, B. (2005). Assessment for learning in English and mathematics: a comparison. *The Curriculum Journal*, 16(2), 153-176.
- Hodgen, J., and Wiliam, D. (2006). *Mathematics inside the black box*. London: NFER-Nelson.
- Kvale, S. (1996). *Interviews: An introduction to qualitative research interviewing*. London: Sage.
- Marshall, B., and Drummond, M. J. (2006). How teachers engage with Assessment for Learning: lessons from the classroom. *Research Papers in Education*, 21(2), 133-149.
- Mitchell, J. C. (1984). Typicality and the Case Study. In R. F. Ellen (Ed.), *Ethnographic Research: A Guide to General Conduct* (pp. 238-241). London: Academic Press.
- Povey, H., Burton, L., Angier, C., and Boylan, M. (1999). Learners as authors in the mathematics classroom. In L. Burton (Ed.), *Learning mathematics: From hierarchies to networks* (pp. 232 - 245). London: Falmer Press.
- Sinclair, J. M., and Coulthard, R. M. (1975). *Towards an Analysis of Discourse: the English Used by teachers and pupils*. London: Oxford University Press.
- Smith, E., and Gorard, S. (2005). 'They don't give us our marks': the role of formative feedback in student progress. *Assessment in Education: Principles, Policy and Practice*, 12(1), 21-38.
- Spillane, J. P. (1999). External reform initiatives and teachers' efforts to reconstruct their practice: the mediating role of teachers' zones of enactment. *Journal of Curriculum Studies*, 31(2), 143 - 175.
- Tobin, K. (1986). Effects of teacher wait time on discourse characteristics in mathematics and language arts classes. *American Educational Research Journal*, 23(2), 191-200.5cm.

## **DEVELOPING STRATEGIES AND MATERIALS IMPACT ON TEACHER EDUCATION**

Marie Hofmannová, Jarmila Novotná

Charles University in Prague, Faculty of Education, Czech Republic

*The paper concerns research of pre-service teacher training. The text deals with attempts to raise the trainees' awareness of the polarity between the transmission and interpretive models of teaching. It is based on the teaching of mathematical content through English to Czech learners (CLIL). Therefore the framework of reference is the didactics of mathematics coupled with methodology of teaching English as a foreign language. In order to adopt and develop good, up-to-date practices, the trainees need to be guided towards more flexibility. This is demonstrated on materials adaptation and use.*

### **INTRODUCTION**

In the last decades, we can notice dynamic development of teaching mathematics at primary and secondary schools. Improvement can be facilitated by changing the content of school mathematics and also through the work of teachers. Their approaches can develop only through personal teaching experiences (Hejny, Novotná, Stehlíková, 2004). Related to this concept of active engagement, is the concept of learning as the construction of personal meaning. In this view, the teacher trainee does not learn solely by acquiring new information or knowledge about teaching, but also through thinking about new ideas, discussing them in the light of the past experience, and reappraising old assumptions in the light of new information.

Traditional concept of education perceived learning as the process of accumulating bits of information and isolated skills. The teacher's task was to transfer knowledge to the students (*transmission model*). The dominating type of interaction during the teaching process was between the teacher and the whole class. Cultivation of the learners' mental representation of world is possible only by deepening their active interest in the subject. The situation where mathematics is taught only as a set of precepts and instructions which have to be learnt leads to ever deeper formalism in the teaching of mathematics, resulting in a lack of understanding of the conceptual structure of the subject and inability to use mathematics meaningfully when solving real problems (Novotná, 1999).

The contemporary view of education requires the students to actively construct meaning. The students are expected to make use of their prior understanding and thoughts. The teacher's task is to generate change in the students' cognitive structure (*interpretive model*). Recent development in general methodology is marked by the shift of emphasis from the teacher to the learner. Preferred behaviour is cooperation.

For this paper, the framework of reference is not only the didactics of mathematics. The authors' main area of research is teacher training for Content and Language Integrated Learning (CLIL), where mathematics taught through English is just one example out of many. This new educational trend is not related to one specific methodology (Pavesi et al., 2001). CLIL is looking for ways how to integrate didactics of content subjects and methodology of foreign language teaching. It requires active methods, cooperative classroom management and emphasis on all types of communication. So far, teacher training courses for CLIL are available in just a few European countries. Generally speaking, their curricula are more open, more flexible compared to those of classical teacher training courses. The authors of the article believe that such conditions provide a favourable starting point for a research experiment.

Educational research includes evaluation of teaching and learning approaches and materials (Duit, 2007). In spite of the fact that the present study comes out of specific conditions in a Czech teacher training course for CLIL, the findings are more general.

## **THEORETICAL BACKGROUND**

In teacher training, the view of mathematics which the trainees have built up during their school career, survives long after they leave school. Teacher training should therefore reflect the contrasting educational concepts and guide the trainees in such a way that they become consciously aware of the polarity in order to associate themselves with the new trends. (Novotná, 1999)

While looking for effective ways of bringing future teachers from theory to practice, the authors are interested in the components that facilitate this task. Doff (1991) states that the aim of teacher training courses is to develop a concept of *good practices* by making the trainees aware of the factors that affect learning and teaching.

Speaking about good classroom practices, we may be thinking of quite different things. We might judge how well the teacher knows the subject, how well s/he teaches the lesson, i.e. makes use of appropriate teaching strategies, or consider how well s/he manages the class – whether s/he involves all the students. This is the area described in teacher training as class management and classroom interaction. For successful teaching, one of the most important things seems to be the balance between teacher and student control. The teacher should not try to control and dominate every aspect of the classroom and the lesson. The purpose of the lesson is to allow learners to learn rather than to demonstrate the teacher's superior knowledge. This means that the teacher must allow the learners to control solving procedures, investigative activities, to ask questions, request further explanation etc.

The teacher's roles are yet another important means of shift of focus from traditional to modern classroom practices. Rogers (1996) places approaches to teaching on the continuum between autocratic and democratic, Wajnryb (1992) holds that the actual sequence, in which the various roles are adopted depend on the lesson plan, its

objectives and processes. Prodromou (1991) gives examples of good classroom activities associated to the following roles: manager, model, monitor, counsellor, informant, facilitator, social worker, and friend.

The role of the teacher is crucial in establishing the appropriate conditions for learner participation. Simon (1995) and Cobb et al. (1997) have shown that collective posing and solving of mathematical tasks, and teachers' facilitation of learners' reflections through reflective discourse lead to greater collective knowledge and development of mathematical thinking. Knowledge and understanding is socially constructed as a result of teacher – student and student – student interaction. Learning mathematics as a discursive activity in collaborative small groups is described e.g. by Forman (1996) or Edwards and Keith (1999). Based on interviews, Edwards and Keith showed the benefit of working together as a group, using different skills, listening to each other and respecting the others in the group. This helped to build confidence and motivation. The results indicated that “students across the attainment range come to appreciate the effectiveness and efficiency” (p. 2-281).

Research on teaching and learning includes empirical studies on various features of the particular learning setting. Research on trainees' perspectives including their pre-instructional conceptions covers the use and adaptation of textbook and instructional materials. When working with textbooks, learning relies on making connections between ideas from the text and prior knowledge and experiences. As regards the innovative use of teaching materials, Candela (1997) found that students' questions and interventions resulted in the transformation of exercises or demonstrations into problem solving and had impact on the knowledge and meaning constructed from experimental activities.

Combining mathematical content with a foreign language brings a number of new learning opportunities. As regards language development, CLIL offers more exposure, thus creating an improvement in the foreign language competence. Second language acquisition (SLA) is made possible by focusing the learners' attention on the content matter. When mathematics is the subject being taught, learners can rely on a symbolic language as well, which helps them to gain more confidence; having a universal symbolic language provides a natural bridge between the language of instruction and the mother tongue. Moreover, CLIL has positive impact on conceptualization. Being able to think about mathematics in a language different from the mother tongue can enrich the learners' understanding of concepts, and help broaden their conceptual mapping resources. This allows better association of different concepts and helps the learners go towards a more sophisticated level of learning in general. (Marsh, Langé, 1999) The tools CLIL approach applies (brainstorming, problem-solving, induction, rule seeking, guided discovery, etc.) maximise the opportunities for the learners to become good, independent and successful. Furthermore, CLIL enhances study skills such as note taking, summarising and extracting key information from texts. Taking information from different sources and



in different languages, re-evaluating and restructuring information can help learners develop thinking skills that can be transferred to other domains.

## **OUR RESEARCH**

The present paper reflects the transition from theory to practice. At Charles University, Faculty of Education, pre-service teacher trainees are not in regular contact with schools. Most of the courses are theory-based which makes their first teaching placements very difficult. Therefore, participants in the CLIL teacher training course are provided with more space for teaching experiments. They are guided from short peer teaching episodes to full length CLIL classes taught in the school setting. Our research therefore includes interdisciplinary implications for the secondary school classroom. Balancing foreign language and mathematical content components is one of the main scaffolding strategies for the course.

Various empirical methods were employed to investigate the optimum educational environment. Our aim was to investigate reflective approach towards teacher training. The sequence of training units was based on materials adaptation and their use in a secondary school classroom. The adapted materials were to achieve equilibrium between mathematics and English. The final stage constituted the feedback session with all the trainees in the CLIL course. The aim was to investigate in what ways the newly adapted materials facilitate changes of teaching strategies, and class management towards more varied classroom interaction.

We were working with two target groups: There were 10 teacher trainees (Group A) and 14 lower secondary school pupils (Group B). Group A were participants of the pre-service optional teacher training course in CLIL, Faculty of Education, Charles University in Prague), Group B came from an affiliated school in Prague.

During the experiment, we made use of the following methods: video recordings of sessions with both Group A and Group B, pre- and post-lesson interviews with group A, analysis of additional data – written comments (reflection on the experiment) collected from Group A.

## **DESCRIPTION OF THE EXPERIMENT**

Since 1999 student teachers can enrol in an optional two-semester CLIL teacher training course integrating mathematics and English. The course combines educational theory and teaching practice, bringing students gradually from lesson observation, mastering subject specific vocabulary and specific knowledge and skills to microteaching of peers based on a variety of materials (e.g. textbooks, student-made worksheets) and concluded with a teaching module. Mathematical content covers mathematics for lower and upper secondary levels (Novotná, Hadj-Moussová, Hofmannová, 2001), the level of English ranges between C1 and C2 of the European Language Framework.

Teacher trainees (CLIL course participants) were asked to choose a mathematical topic to be developed at the lower secondary level. At first, they worked with traditional materials, later they decided adapt one of them and develop it into a lesson plan. The lesson was first simulated in the teacher training course in the form of peer teaching, and later taught in a real classroom.

Original materials come from Mathematical Rally Transalpine 2004. Here is an example of a problem<sup>1</sup>:

*Bizarre colouring*

Maxime is filling in a square grid. In each line, the rule of colouring is different:

1	2	3	4	5	6	7	8	9	10	11	12	13	14	15	16
---	---	---	---	---	---	---	---	---	----	----	----	----	----	----	----

He has already filled correctly the first 15 columns. He states that the columns 1, 9 and 13 are fully filled. He continues with column 16.

Will column 83 be fully filled? And column 265?

Explain how you have found the solution.

Mathematical topics were solving word problems, patterns combining arithmetic, algebra, geometry, combinatorics, etc. The training aimed at material development to enhance learners' motivation.

The first task in the CLIL course was to let the trainees solve the problem as if they were secondary school learners. They came up with a variety of solving procedures. They compared them and discussed the necessary knowledge and skills for each solution (from the learners' perspective).

The second task was to prepare a mock lesson plan for team/peer teaching. After trying and testing during the following seminar, the trainees suggested changes for the plan to be executed in real class conditions.

*The first phase* of the activity took place as team teaching in the training course with the participation of ten teacher trainees, 22-25 years of age. It took place in 45-minute training session during four successive weeks. The programme covered:

- a priori analysis of the text of the presented problem (discussion from the perspective of possible mathematical solutions and language of the assignment)

---

<sup>1</sup> For more details, see (Favilli, 2006).

- preparation of the lesson in the following steps:

The trainers and trainees discussed how to best prepare the microteaching of peers. They assigned roles and prepared the first draft of lesson plan.

Peer-team teaching: One stage of the proposed lesson was taught by two student teachers, the remaining trainees played the roles of pupils. One trainer took notes on the blackboard for further feedback.

Reflecting and analyzing the training lesson: Trainees presented critical remarks both to the wording of the problem and the execution of the lesson plan. The necessity to change the assignment in order to fit real life was emphasized. The trainees volunteered to prepare a new teaching material that would better correspond with the learners' age and interests. For the result see extracts from "Fashion World Magazine" in the Attachment.

*The second phase* of the activity took place in the classroom in a secondary school in Prague. It lasted 45 minutes. The lesson was to be devoted to a foreign language, i.e. why trainees worked with half of the original group. Fourteen pupils, 15-16 years of age, participated in the lesson. The programme covered an ice-breaking activity "Name scrabble", revision of mathematical vocabulary (the lesson was conducted in English), solving the original version of the problem either individually or in pairs, pupils solving the "Fashion World Magazine" (the whole class, group and individual work was organized), and checking the results with the whole class.

*The third phase* - a posteriori analysis of the lesson - took place again in the training course. We believe that by means of classroom observations and subsequent analyses, the trainees are to be encouraged to look for important characteristics of good teaching strategies. The discussion was based on observations and the video recording of the whole lesson. The items discussed were: lesson analysis, comments, critical remarks, and suggestions for alternatives. Attention was paid to the following observation categories: teacher, learners, and materials.

During the process of material adaptation, the trainees modified both the context and assignment of the original problem. The new version differs from the original one for fantasy and originality: the idea of a contest based on a mathematical quiz to get great discounts or a free T-shirt makes the problem concrete, closer to real life. The innovative aspects of the material are dual-focused. They do not concern only mathematics. The "Fashion World Magazine" contains diverse language input.

## **CONCLUDING REMARKS**

It can be concluded that CLIL methodology stresses the interrelatedness of language, content and cognition of the learner, covering also the cultural dimension of learning. It is learner-centred and assumes a shift in a role of the teacher. Innovative CLIL teaching strategies applied were found motivating and useful by all the participating student teachers. This experiment was accepted as a pilot activity in LOSST-IN-

MATH Socrates Comenius 2.1 project. “In spite of differences in European mathematics teacher training systems the project aims at contributing to greater sharing of good practices in this field. In order to fulfil this task, changes in the curricula for lower secondary school mathematics teacher training are proposed as a result of the piloting of a number of educational modules.” (Favilli, 2006).

Originally the text “Bizzare colouring” was proposed in Italy as a means of presenting the Theory of didactical situations (Brousseau, 1997). The material was co-piloted in two countries. In the Slovak Republic, the same original text was used as an example of the development of learners’ cognitive processes in mathematics.

To conclude, let us quote Favilli (2006): “The aim is to influence in a positive way not only teacher training, but also the school reality, through the development of mathematical education projects which intend to be more learner-friendly and attractive to pupils.” (Introduction)

## REFERENCES

- Brousseau, G.: 1997, *Theory of Didactical Situations in Mathematics*. [Edited and translated by Balacheff, M. Cooper, R. Sutherland and V. Warfield]. Kluwer Academic Publishers, Dordrecht/ Boston/London.
- Candela, A.: 1997, ‘Demonstrations and problem-solving exercises in school science: Their transformation within the Mexican elementary school classroom’, *Science Education*, 81, 5, pp. 497-513.
- Cobb, P., Boufi, A., McClain, K. and Whitemack, J.: 1997, ‘Reflective Discourse and Collective Reflection’, *Journal for Research in Mathematics Education* 28, 3, pp. 258-277.
- Doff, A.: 1991, *Teach English. A training course for teachers. Trainer’s handbook*, C.U.P.
- Duit, R.: 2007, ‘Science Education Research Internationally: Conceptions, Research Methods, Domains of Research’, *Eurasia Journal of Mathematics, Science & Technology Education*, 3, 1, pp. 3-15.
- Edwards, J.-A. and Keith, J.: 1999, ‘Students’ views of learning mathematics in collaborative small groups’, in O. Zaslavsky (ed.), *Proceedings of the 23th PME*, Haifa, Vol. 2, pp. 281-288.
- Favilli, F. (ed.): 2006, *LOSSTT-IN-MATH – Lower Secondary School Teacher Training in Mathematics. Towards a European teacher training curriculum*. PLUS, Pisa.
- Forman, E.: 1996, ‘Learning mathematics as participation in classroom practice: Implications of sociocultural theory for educational reform’, in L. Steffe, P. Neshier, P. Cobb, G. Goldin and B. Greer (eds.), *Theories of mathematical learning*, Lawrence Erlbaum Associates, Inc., Mahwah, NJ, pp. 115-130.

- Hejný, M., Novotná, J. and Stehlíková, N.: 2004, *25 kapitol z didaktiky matematiky* [25 Chapters from Didactics of Mathematics] (2 volumes.), UK-PedF, Praha. (In Czech.)
- Novotná, J.: 1999, 'Učitel v roli žáka – součást profesní přípravy učitele', *Pedagogická orientace* 1999, No. 3, pp. 28-32. English translation: 'Teacher in the role of a student – a component of teacher training', <http://www.pedf.cuni.cz/svi/vydavatelstvi/ucitel/konfaj.htm>.
- Novotná, J., Hadj-Mousová, Z. and Hofmannová, M.: 2001, 'Teacher training for CLIL – Competences of a CLIL teacher', in J. Novotná and M. Hejný (eds.) *Proceedings SEMT 01*, UK-PedF, Praha, pp. 122-126.
- Pavesi, M., Bertocchi, D., Hofmannová, M. and Kazianka, M.: 2001, *Insegnare in una lingua straniera*. Gen. ed. Langé, G. Milan: M.I.U.R for TIE-CLIL.
- Prodromou, L.: 1991, 'The Good English Teacher', in: *English Teaching Forum*, April 1991.
- Rogers, A.: 1996, *Teaching Adults*, Open University Press.
- Simon, M. A.: 1995, 'Reconstructing Mathematics Pedagogy from a Constructivist Perspective', *Journal for Research in Mathematics Education* 25, 1, pp. 50-85.
- Wajnryb, R.: 1992, *Classroom Observation Tasks*, Cambridge University Press.
- Acknowledgment: The training activity was supported by the Socrates Comenius 2.1 project LOSSTT-IN-MATH – Lower Secondary School Teacher Training IN MATHEmatics. Project reference: 112318-CP-1-2003-1-IT-COMENIUS-C21.

ATTACHMENT

**TO BE SQUARED=TO BE IN**

It is a simple equation. If you want to be IN in the coming spring season, put on a squared T-shirt. According to reputable fashion designers, the season will be full of squares. In this edition of the Fashion World Magazine, you can order a T-shirt with any squared patterns you can imagine. In addition to this, you can get **great discounts** or a **T-SHIRT GRATIS** ! Join our contest and win a **MAGNIFICENT T-shirt!**



Don't miss your chance and order a T-shirt. Only now you can choose your own pattern!



**FASHIONS**  
*then & now*



Follow fashion, don't fall behind!

---

Advertising

Visit the biggest shopping centre!

**High discounts! Great Choice! The lowest price guaranteed! Favourable staff!**

Londýnská 128, Prague 2, +420 298563128



**THE FASHION CENTER**

Using the newly adapted text means working in more detail with components of the language system, e.g. grammar issues (e.g. examples of interference), lexical issues (specialized terminology, e.g. “Explain what an equation is.”)

**Question No.1**

Is this a pattern from our set?

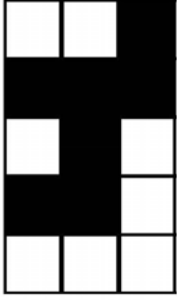

**Question No.2**

If our catalogue contained all the other patterns, what would the pattern no. 16 be like? (Blacken the appropriate squares!)

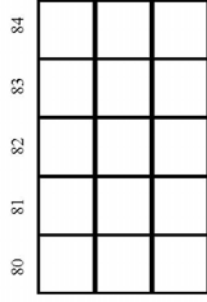

**Question No.3**

What is the number of this pattern? (If there are more possibilities, write ALL of them!)

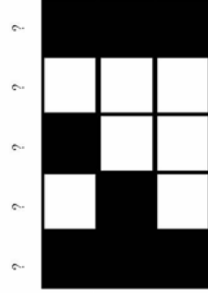

**Question No. 4**

Choose a pattern from the set and write the appropriate number.

Using the newly adapted text offers the opportunity to look at the mathematical situation from different perspectives and change algorithms to problem solving towards a more creative approach.

These patterns were prepared by our designers only for you.

PATTERN No.1

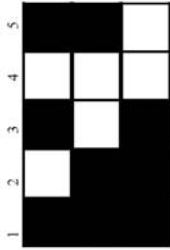

PATTERN No.2

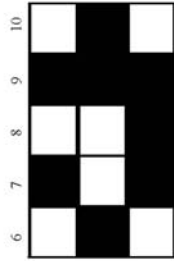

PATTERN No.3



PATTERN No. 4

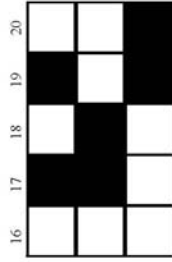

## **DIFFERENCES AND SIMILARITIES IN (QUALIFIED) PEDAGOGICAL REFLECTION**

Alena Hošpesová, Marie Tichá, Jana Macháčková

University of South Bohemia České Budějovice, Institute of Mathematics of the  
Academy of Sciences of the Czech Republic

*The paper is a continuation of the contribution presented at CERME4 conference “Developing mathematics teacher’s competence”. It also covers the issue of professional development of teachers and mechanisms for enhancement of teaching. In the centre of our attention is qualified pedagogical reflection and exploration of how this reflection differs from person to person. We also study how confrontation of various points of view in the process of joint reflection can contribute to any change of attitude of its individual participants. The purpose of this paper in theoretical terms can be seen as bringing a research dimension to the study of the processes relating theory to practice.*

### **STARTING REMARKS**

Professional formation of teachers is regarded as a crucial element in the effort to improve culture of mathematics classroom. The competence of qualified pedagogical reflection is rated as one of the key features of a teacher’s professionalism. (Bruner, 1996; Krainer, 1996; Climent & Carrillo, 2001; Helus, 2001; Jaworski, 2003). Systematic reflection of one’s own activity, decision-making processes and pedagogical situations foster transition from intuitive to conscious behaviour. Therefore it is one of the key elements of professional development not only of student teachers but also of practicing teachers. A wider range of techniques of systematic qualified reflection will allow its participants deeper inner dialogue (Scherer et al., 2004; Svec, 1996). Reflection is also a substantial component of action research whose main participants are practicing teachers (Jaworski, 2003; Schön, 1983).

### **Diversity in reflections**

In our understanding the notion of reflection includes observation, contemplation, and consideration. If we want to speak about a qualified pedagogical reflection, then we examine teaching from the point of view of goals and content of the teaching, and methods of work and their realisation in mutual relation.

The meaning of the word “reflection” is not understood equally by mathematics educators and/or researchers (e.g. Cobb et al., 1997; Schön, 1983). The ambiguity in perception of this word was also apparent in statements of participants of both Czech and international (e.g. PME, CIEAEM) workshops focused on reflection of teaching episodes. We believe that this was not due to language differences.

The problem of ambiguity is not only connected to the specification of the concept of reflection. Reflections of a particular teaching episode carried out by different people



vary to a considerable degree. This equivocalness can be even observed in people with similar point of view and professional orientation. Let us now illustrate equivocalness of one teaching experiment from our own experience. The teaching episode, which was consequently reflected upon, was prepared by one of the co-authors of this contribution (for details see Tichá et al., 2005). Immediately after experimental teaching, processing of its video recording and elaboration of transcript, we worked out individual reflections of the experiment (the teacher who implemented the experiment; Res 1 who observed the episode in the classroom and who made the video recording; Res 2 who did not participate in the lesson but who cooperated when making the transcript; they all know each other, collaborate in various research and are co-authors of this paper). The focus of the teaching experiment was the role of the whole when grasping the concept of fractions.

The teacher's considerations can be labelled as "reflection upon reflection". She focused on the relevance of joint reflection for a teacher as it is the activity which enables him/her: (a) to realize important phenomena which would otherwise remain unnoticed; (b) to understand pupils' thinking and reasoning in more depth; (c) to record and clarify ambiguities. She also discussed general questions connected to carrying out joint reflections in schools (how to persuade teachers about usefulness of joint qualified reflection, how to create atmosphere in which teachers would feel the need of joint reflection ...).

Res 1 emphasized that she always focused on finding out when and why problems of pupils with understanding occur, on how to eliminate their causes and how to reduce any possible lack of understanding. As far as the teacher's performance is concerned, she focused on: what she had been doing, why and how her performance could have been different. As far as pupils are concerned, she concentrated on (a) the level of understanding of mathematical content, (b) development of pre-concepts, (c) the nature of reasoning, (d) the course of communication. She registered pupils' difficulties, namely (a) inhibiting influence of previous knowledge, (b) formal knowledge without understanding.

Res 2 characterized her approach to reflection as observation of how a pupil learns in the social context of his/her class. At first, she described her overall impressions from the whole teaching episode: (a) the pupils are advanced, (b) the teacher was able to structure the lesson well. After these general remarks, she focused on observing what exactly "was going on in the classroom". "I tried to find out: (a) what idea might have preceded a particular pupil's statement, (b) how pupils influenced each other, (c) what means the teacher used to make so many pupils participate actively in the lesson." These considerations were concluded by a series of questions concerning the causes of the teacher's and pupils' behaviour and action.

Our belief that different people reflect upon identical situations diversely, which experience from the presented example confirms, resulted in the decision to compare our reflections with reflections of other people. Another reason for this decision was

that we had supposed this would lead to a more substantial exposition of characteristic features of reflections.

### **Self-reflection, individual reflection, joint reflection**

The term reflection is often used in the sense of self-reflection. We believe that self-reflection is to a certain degree present in every human activity. When solving the Comenius project (Tichá & Hošpesová, 2006) we found out that teachers' self-reflection of their own teaching is often based on intuitive perception of what the teachers considers being the "right teaching".

To the contrary, some authors argue that it is necessary to carry out and systematically develop not only self-reflection, but also joint reflection (Tzur, 2001; Cobb et al., 1997). Scherer and Steinbring (2004) stress the demandingness of the work of the teacher of mathematics, from which follows necessity to move to "qualified preparation and qualified joint reflection of everyday teaching activities". We share this point of view. The attribute "qualified" denotes such pedagogical reflection, which incorporates analytical thought on the teaching objectives and content, teaching methods and their execution. Under no circumstances can it be regarded as a mere "feedback". It includes description and analysis of key elements, phenomena and personal experience, their evaluation and processing, looking for causes of some particular behaviour and for other possible behaviour, and making decisions about a new strategy (according to Slavík & Siňor, 1993).

In our opinion the competence to carry out "qualified pedagogical reflection" is one of fundamental teacher's competences. That is why we believe that it is necessary to cultivate reflection (as well as other professional teachers' competences, Hošpesová & Tichá, 2005), to teach both student teachers and practicing teachers to ask questions, answers to which will subsequently lead to deeper understanding of (one's own) teaching. The teacher who taught the lesson provides the "view from the inside". External points of view can be expected from people who were given the chance to observe the lesson and are therefore able to observe the teaching from some distance. However, also the teacher who actually taught the lesson needs to have a chance to get a detached look at himself/herself. That is why we started to supplement individual reflection by joint reflection whose various participants confront their opinions on a particular teaching episode. In these joint reflections, the diversity of individual reflections is of much benefit because it shows the participants other possible points of view than just their own (Tichá & Hošpesová, 2006). Joint reflection can therefore become one of the ways of reflection cultivation.

### **PROCEDURE USED**

Our investigation consists of a study during which different groups of professionals from the field of mathematics education individually and jointly reflected upon a short teaching episode. It bears attributes of qualitative research. As far as the main goal was to understand participants' perspectives, our research looked at the problem from the interpretative point of view.

We asked other colleagues to reflect individually on the above mentioned teaching episode: (a) primary and lower secondary school teachers, (b) student teachers, (c) doctoral students in didactics of mathematics, (d) teacher educators, and (e) researchers. The video recording and transcript of the episode were at their disposal. They were asked to express their view of the teaching episode and to produce a written individual reflection of the teaching episode.

The individual reflection later served as the basis for joint reflection. The individual reflection was usually followed up by a discussion of the reflecting persons. We worked both with homogeneous groups (i.e. the group consisted of people with identical professional orientation – students, teachers, educators, researchers) and heterogeneous groups.

## **COURSE OF INVESTIGATION AND SOME RESULTS**

The analysis of comments confirmed our expectations that reflections share common features. What came to us as a surprise was that representatives of all groups (Czech and foreign) inclined to description of action, events and personal impressions; their reflection was of highly narrative character. Even many researchers did not from the very beginning of reflecting consciously aim at critical analysis; it appeared only in later stages.

### **Students**

Due to the fact that reflection may arise from one's own individual needs or may be brought about from the outside, pre-service students were set the task in two different ways:

- a) Without offering any scaffolding/frame, questions from the outside, only with instruction: "Write down what you found interesting and inspiring in the teaching episode."
- b) Attention of reflecting students was in advance drawn to what phenomena they should focus on. The tasks were: "Pay attention especially to: (1) how the pupils understand the topic, (2) intentions of the teacher during the course of the lesson, (3) interaction among the pupils and between pupils and the teacher, (4) the teaching activities of the teacher."

Those students who were working without any frame questions usually concentrated on the wording of the assigned task and on the contribution of individual pupils. In their comments they did not attempt to analyse, they rather "recounted" what was going on in the lesson. However, they were also perceptive to the nature of interaction between the teacher and the pupils. They ascertained that the teacher kept asking questions whose aim was to lead the pupils to the core of the problem. At the same time the teacher was criticized for speaking only to some of the pupils in the discussion.

Comments of the group whose reflection was supported by the above mentioned tasks (b) referred to points 1. – 3. from the list. It seems that so far the students have

not been able to identify with the role of the teacher to such an extent that they would feel apt to evaluate the teaching activities of the teacher. In most comments of these groups one can observe attempts at deeper analysis: the wording of the problems, the structure of the lesson, interaction of the pupils and the teacher. The comments on intentions of the teacher disclose an effort to understand the “teaching profession”. It seems that the scaffolding is of considerable benefit. In some cases, reflection without the frame of assigned partial tasks is hardly possible.

There were also some students who applied their knowledge from their studies of pedagogy. They for example tried to clarify the term reflection using the learned frame of aspects (“Before the lesson: my objectives, what methods, .... . During the lesson: change of objectives, time management, ... . After the lesson: Did I reach my objectives? Did the method work? Was my organization of the class effective? How did I feel? ...”). In concrete comments regarding the teaching episode they used learned formulations, e.g.: “Interaction in the class has the form of controlled discussion whose dominant participant is the teacher as the control apparatus. As far as the children are concerned, reactions are only the matter of a limited group of children. In our opinion, the reconstruction of the word problem has the nature of open teaching where solution is formed within the pupils with the help of open and guiding questions of the teacher.”

We made a specific experience with doctoral students at YERME 2006, where several questions arose: How should reflections be carried out? Evaluated? Analysed? Reflected upon? How should reflections be cultivated?

### **Teachers**

When working with practicing teachers, we used a modified variant of the work done with the students. The teachers were first asked to make a record of the teaching episode on their own and to include everything that they found relevant. Then we acquainted ourselves with the records and consequently met their authors. Before the meeting, the teachers had been offered translation of a passage from the instruction for teachers (Scherer et al., 2004), which can be regarded as a “guide through reflection of teaching”. Our aim was to create stimulating environment for joint reflection. Therefore we also prepared several questions, which were meant to serve as milestones of this reflection. We tried to word such questions which would enable (a) description of what the teacher was doing, how her pupils reacted, what the course of communication was, ... (b) analysis of the situation and of the causes of behaviour and action of the pupils (e.g. Why did I do exactly what I did, What were my motives?), (c) search for other possible behaviour.

What became manifest from teachers’ records was their inexperience with work with video recording and transcripts. The teachers were not aware of the necessity to (a) watch the video recording repeatedly, (b) choose such episodes which are interesting from their point of view and watch them several times. They were obviously at a loss

how to describe, analyse and structure pedagogical experience from school practice (according to Slavík & Siňor, 1993).

The written records of this group of teachers can be characterized as records of moments, unstructured summary of observations from the teaching episode. At the same time, it was proved that carrying out reflection is very demanding as far as the following factors are concerned: (a) professional knowledge of the teacher, mastering of mathematical content and its didactical analysis and processing, (b) comprehension of the function of joint reflection (the teachers supposed that the aim of our discussion was evaluation of the teacher, they did not realize that what was at stake was cultivation of the teacher's competences and consequently improvement of his/her teaching, which would result in deeper understanding and knowledge of the pupils). The problem here is that the teachers recorded neither interesting nor relevant phenomena from the point of view of concept formation (different presentations, formation of pre-conceptions etc.).

Let us now summarise the hitherto presented observations. The teachers tended to focus on: (i) Compliance with traditional pattern of good lesson structure, (ii) General didactic questions, methodology, (iii) Striking/spectacular, but from the point of view of the teacher's objectives marginal moments, (iv) Things that can be regarded as "the teacher's mistakes", (v) Whether the teacher did everything that they find important. Teachers disregarded and did not consider especially: (i) Possible alternatives of approach to teaching, (ii) The teacher's competences and professionalism, (iii) Deeper insight into less striking moments which are nevertheless crucial for the course of the lesson, (iv) The reasons why the teacher adopted a step which they find erroneous, (v) Whether the steps they find necessary correspond to the objectives of the teacher.

Our impression was that the teachers did not try to mention the whole complex of interacting phenomena. They did not display the intention and effort to choose didactically interesting moments (interesting, unexpected solutions and reactions of the pupils and the teacher). What was really surprising was that they also did not perceive lesson structure and the function of its constituent phases.

This was confirmed by our other experience, when we gave the teachers several frame questions, which they should concentrate on. In spite of that the teachers in discussion adhered to their criteria and kept referring back to them. Our attempt to "shift" the centre of attention, to introduce other important questions into the discussion and to find out the teacher's view of them usually remained unnoticed.

These facts are, in our opinion, the consequence of different professional preparation and teacher's beliefs on subject-matter and sense of mathematical education. The teachers in their daily occupation seem to be concerned mostly about the mathematical content elaboration, teaching methods, organization of pupils and lesson structure; they need not necessarily realize that "small factors" like the way of classroom communication might have serious impact on pupil's learning.

Our findings outlined the need of *conceptual change* of their grasping of reflection and showed the importance of subject didactical competence.

### **Teacher educators and researchers**

As expected, reflections of teacher educators and researchers were of very different character. These reflections were obtained from participants of several workshops on Czech seminars and international conferences. Undoubtedly, these reflections are to a great extent influenced by research interests of each of the participants. For example researchers who engage in cognitive processes commented on individual steps of the pupils and simultaneously tried to unravel their way of thinking and its causes. Teacher educators paid a lot of attention to the wording of the problem, its accuracy, comprehensibility to the pupils, possible obstacles and possible cognitive conflict.

### **Specification of the notion of reflection versus carrying out of reflections**

In some workshops (whose participants were students, teacher educators, researchers working in groups), we advanced in two stages:

a) First the participants were asked to answer the question: What is reflection? What do you imagine on hearing the term qualified pedagogical reflection? What should reflection include?

b) Then the participants were asked to carry out reflection of the above-mentioned teaching episode under identical circumstances as the other groups, using video recording and transcript.

Answers to question (a) were usually articulated with the aim to clarify what teachers should be prepared for, what a reflecting teacher should be aware of. They usually had the form of lecture for students: “teacher should try ..., apply ..., use at least ...”, or they offered types of observations and questions that the teacher should ask during his/her reflection: “Did you plan work? Did you notice students’ difficulties? ...” Typically, the participants tried to make a list of characteristic features of various degree of universality (we encountered both “grand ideas” and very particular lists of items and phenomena that should be taken into account and studied).

There were disproportions between (a) and (b), i.e. differences between theoretical approach (proclamations) and execution, reflection on a concrete situation in which views stated in (a) were not taken into account. Only loose connection between the two stages could be observed. In answers to (a), participants formulated general objectives of reflections, what their focus should be, but these aims were not concretized in (b).

One group in stage (a) pointed out what must be considered/studied: “To think about: students’ thinking, interaction, design of suitable activities, affective domain, assessment, ...” Nevertheless, statements in (b) were again only general: reflections on students’ argumentation, reaction to social interaction (the question one must ask here is whether this was not caused by lack of understanding of the language), i.e. they were not linked to the observed teaching episode.

It is natural to ask what stands behind these disproportions. Lack of time? Variety/lack of experience? Awareness that “This is how it should be.” on the one hand and execution on the other hand.

## DISCUSSION

As was mentioned in the beginning, differences in reflections come to us as no surprise, “... they are caused by differences in knowledge, experience and predispositions of individuals, by unequal quality of interpretation, by uniqueness of causal attributions (assignment of causes) ... all these influence intuitive selection and use of assessment criteria ...” (Slavík & Siňor, 1993). What mainly influences different groups of reflection participant in our survey was professional orientation. Commentaries of different groups can be briefly characterized:

- teachers’ commentaries involve on the one hand (in comparison to commentaries of other groups to a great degree) criticism of the observed teaching, on the other hand they display clear tendency to look for a guide, methodology, one correct way “what it should be like”,
- students applied theoretical knowledge acquired in the course of their studies, however, most often it was a mere reproduction of it,
- researchers and teacher educators produced a much wider range of observations: regarding mathematical content and how it is handled by the teacher, the teacher’s teaching style, issues related to cognitive development of the pupils and to metacognition.

We noticed considerable differences in how particular aspects were evaluated. For example students appreciated that the teacher does not intervene much and lets the pupils reason and argue on their own. Contrary to this, “reflecting teachers” felt intervention from the teacher’s side to be insufficient.

It was clear that although the objectives of researchers and teachers seem to be identical – to improve teaching and achieve higher standard of education – they are in fact very different. Researchers look for answers to theoretical questions while teachers deal with practical problems.

Further research is needed if the relation between joint reflection and (a) pupils’ mathematical learning, its quality and results, (b) development of teachers’ competences is to be revealed, interpreted and evaluated. However this requires that methods and tools for research in this area should be found.

In discussions with all groups (in the course of seminars and conference both national and international like PME, CIEAEM, YERME) we kept referring to several frame questions:

- What are the benefits of cooperation between teachers and researchers?
- What criteria are characteristic for a “reflective teacher” and especially for a “research teacher”? What really is “action research”?

- Is it possible for a teacher to do research work? Are there communities of teacher researchers? How to deal with confusion of being a teacher and being a researcher?
- How can university people support teachers/researchers to reflect more deeply?
- Are the concerns that carrying out joint reflections is violation of “intimacy” essential if participants are to be “open” legitimate?
- A teacher has different tensions and priorities than a researcher. How does a teacher-researcher balance these tensions?
- What are the ethical implications for doing this kind of research collaboration?

In frame of discussion in the course of CERME 5 group 12 emerged further questions:

- Is (the notion of) reflection culturally specific? Are there different forms of joint reflection in different contexts?
- Can we reflect without purpose? Is awareness necessary for reflection or is it a consequence of it?
- What is the role of the “expert” in collaborative groups?

This paper focuses on the process of reflection and idiosyncratic differences in this process. Our primary objective is to find how to cultivate teachers’ competences. Joint reflection seems to be one of the possible ways because it stimulates some teachers to reflect on their own competences and leads to changes of attitudes (however, the prerequisites here are subject didactical competences (Hošpesová & Tichá, 2005) in didactics of mathematics which make realization of one’s weaknesses possible and open way to their elimination). Nevertheless, we also saw teachers joint reflection on whom was of contrary effect: they realized that “something was not right” and consequently lost self-confidence.

We are fully aware that carrying out joint reflection calls for specific conditions and poses great demands on all participants in various areas (mutual relationships, professional knowledge, social, etc.). Unluckily, that is why joint reflection will quite likely remain only an exceptionally used method.

## NOTES

1. This research was partially supported by the grant GACR 406/05/2444 and by Ac. Sci. Czech Republic, Institutional Research Plan No. AV0Z 10190503.

## REFERENCES

- Bruner, J. (1996). *The culture of education*. Cambridge: Harvard University Press.
- Climent, N. & Carrillo, J. (2001). Developing and Researching Professional Knowledge with Primary Teachers. In: J. Novotna (Ed.), *CERME 2., Part 1*. Prague: Charles University, Faculty of Education, 269-280.



- Cobb, P., Boufi, A., McClain, K. & Whitenack, J. (1997). Reflective discourse and collective reflection. *Journal for Research in Mathematics Education*, 28 (3), 258-277.
- Helus, Z. (2001). Čtyři teze k tématu „změna školy“ (Four Theses on School Reform, in Czech). *Pedagogika*, vol. 51(1), 25-41.
- Hošpesová, A. & Tichá, M. (2005). Developing mathematics teachers' competences. In: *CERME-4* <http://cerme4.crm.es/papers20%definitius/12/hospesová.pdf>
- Jaworski, B. (2003). Research practice into/influencing mathematics teaching and learning development: Towards a theoretical framework based on co-learning partnerships. *Educational studies in mathematics*, 54 (2-3), 249-282.
- Krainer, K. (1996). Some considerations on problems and perspectives of in service mathematics teacher education. In: C. Alsina et al. (Eds.), *8<sup>th</sup> International congress on Mathematics Education: Selected Lectures*. Seville: SAEM Thales, 303-321.
- Scherer, P., Söbeke, E. & Steinbring, H. (2004). *Praxisleitfaden zur kooperativen Reflexion des eigenen Mathematikunterrichts*. Manuscript: Universitäten Bielefeld & Dortmund
- Scherer, P. & Steinbring, H. (2003). The professionalisation of mathematics teachers' knowledge – teachers commonly reflect feedbacks to their own instruction activity. In: *CERME 3* [http://www.dm.unipi.it/~didattica/CERME3/WG11/papers\\_pdf/TG11\\_Scherer.pdf](http://www.dm.unipi.it/~didattica/CERME3/WG11/papers_pdf/TG11_Scherer.pdf)
- Schön, D. A. (1983). *The reflective practitioner*. London: Temple Smith.
- Slavík, J. & Sinor, S. (1993). Kompetence učitele v reflektování výuky (The teacher's competence in reflection of teaching, in Czech). *Pedagogika*, 43 (2), 155-164.
- Svec, V. (1996). Sebereflexe studentů v pregraduální didaktické přípravě (Student's Self-Reflection During the Undergraduate Didactic Education, in Czech). *Pedagogika*, 46 (3), 266-276.
- Tichá, M., Hošpesová, A. & Macháčková, J. (2005). Mathematics classroom and collective reflection. In: J. Novotná (Ed.), *International Symposium Elementary Maths Teaching. Proceedings*. Praha: Charles University, Faculty of Education, 307-315.
- Tichá, M. & Hošpesová, A. (2006). Qualified Pedagogical Reflection as a Way to Improve Mathematics Education. *Journal of Mathematics Teacher Education, special issue: Inter-Relating Theory and Practice in Mathematics Teacher Education*, ( 9) 2, 129-156.
- Tzur, R. (2001). Becoming a mathematics teacher-educator: Conceptualizing the terrain through self-reflective analysis. *Journal of Mathematics Teacher Education*, 4, 259-283.

# **PRE-SERVICE TEACHERS' REPRESENTATIONS OF DIVISION OF FRACTIONS**

Mine Isiksal and Erdinc Cakiroglu

Middle East Technical University, Turkey

*The purpose of this study is to investigate pre-service mathematics teachers' use of representations in order to reason about their understanding on division of fractions. Data was collected from 17 Turkish pre-service teachers at the end of the spring semester of 2004-2005 academic year. Qualitative design was used to support methodological perspective where data was collected through Division of Fractions Questionnaire and semi-structured interviews. Results revealed that pre-service teachers' representations to reason about their understanding on division of fractions were limited to their pre-university familiarity.*

## **INTRODUCTION**

Students in elementary schools generally have difficulties in developing an understanding of mathematics concepts, which are abstract in nature. Most of the students just memorize the specific rules related to a subject without questioning them (Mack, 1990; Ball, 1990a). Operations with fractions are one of these topics. Mack (1990) emphasized that although many students memorize the rote procedures needed to manipulate the symbols, they soon forget the procedures and thus find it difficult to learn fractions. Operations with fractions, specifically division of fractions where conceptual understanding is critical, often considered the most mechanical and least understood topic in elementary school (Fendel, 1987; Payne, 1976; Tirosh, 2000). Carpenter et al. (1988) stated that children's success rates on various tasks related to operation on fractions are usually very low.

The importance of representations used for defining mathematical expressions recently draws most researchers' attention. Researchers emphasized that representations are cornerstones in both teachers' content and pedagogical knowledge (Shulman, 1986; McDiarmid, Ball, & Anderson, 1989). McDiarmid et al., (1989) stated that instructional representations are central to the task of teaching subject matter. "To develop, select, and use appropriate representations, teachers must understand the content they are representing, the ways of thinking and knowing associated with this content, and the pupils they are teaching" (p.198). Likewise, Ball (1990b) pointed out that teachers should understand the subject in depth to be able to represent it in appropriate and multiple ways like story problems, pictures, situations, and concrete materials.

Lesh, Post, and Behr (1987) identified five distinct modes of representations in case of mathematical learning and problem solving: (1) real-word situations- where knowledge is organized from real life; (2) manipulatives-like fraction bars, Cuisenaire rods (3) pictures or diagrams-like number lines, region, discrete models

(4) spoken symbols-can be everyday language (5) written symbols-specialized sentence and phrases (Lesh, et al. 1987, p.38). In addition to the five distinct types of representational modes, translation among modes and transformations within them were also important (Ainsworth, Bibby, & Wood, 2002; Behr et al., 1983, Cramer, 2003; Lesh et al. 1987). Thus, translation among representations aim to require students to establish a relationship from one representational system to another, keeping the meaning same. This model emphasized that realistic mathematical problems are usually solved by translating from the real situation to some system of representation, transforming within the representational system to suggest some solutions, and then translating the result back to the real world. The model also emphasized that many problems are solved using several representational modes.

Recent curriculum reform movement in Turkey also emphasized the importance of developing students' abilities in problem solving and communication through multiple representations. In order to develop fractional understanding, children should practice the use of multiple representations (MNE, 2002). However, results of the examination of Turkish middle grade students' abilities in translating among representations of fractions were low due to the limited conceptual understanding on the concept of fractions (Kurt, 2006). Similarly, Ball (1990a) mentioned that majority of American students entering elementary and secondary pre-service teacher education programs are not able to select or generate appropriate representations for division of fractions. Additionally, Kieren, Nelson, & Smith (1985) highlighted the need for children to build a deep understanding of fractions by using variety of concrete and pictorial models.

It is obvious that one of the essential elements in improving instruction and students' understanding in the mathematics classroom is the role of the teacher. NCTM (1991) emphasized that "Teachers must help every student develop conceptual and procedural understandings of numbers, operations, geometry, measurement, statistics, probability, functions, and algebra and the connections among ideas" (p. 21). Thus, in order to develop conceptual and procedural understanding of the students, teachers should understand the content from both perspectives. Tirosh (2000) stated that a major goal in teacher education programs should be to promote development of pre-service teachers' knowledge of common ways children think about the mathematics topics the teacher will teach. Since many of tomorrow's in-service teachers are today's pre-service teachers, great emphasize is given to the pre-service teachers' knowledge of subject matter knowledge and pedagogical knowledge. She mentioned that the experience acquired during the course of teaching is the main but not the only source of teachers' knowledge of students' common conceptions and misconceptions. Pre-service teachers' own experiences as learners together with their familiarity with relevant developmental and cognitive research could be used to enhance their knowledge of common ways of thinking among children.

Based on the literature above, in this study it was aimed to study pre-service mathematics teachers' knowledge on representations in order to reason about their understanding on division of fractions. It is believed that this study allowed the authors to glimpse at pre-service teacher's constructions of knowledge and their alternatives to the traditional view of the expected procedure (invert and multiply) that children should learn for division of fractions. Thus, in this research study, pre-service teachers' representation models that they used to reason about their understanding of division of fractions were examined. This study aims to answer the following question:

- What kind of representations/modeling do pre-service elementary mathematics teachers use to reason about their understanding of division of fractions?

## **METHOD**

### **Participants**

In this study, since the aim was to gain an in-depth understanding of the pre-service teachers' representation models, qualitative research methodology was used to support methodological perspective and findings of the research study. Data was collected by using purposive sampling from 17 Turkish pre-service teachers enrolled in an undergraduate teacher education program (see below) in Ankara, Turkey at the end of the spring semester of 2004-2005 academic year. Pre-service teachers graduated from the program are potential teacher candidates who can teach mathematics at upper elementary and middle grade levels. The underlying rationale for choosing senior pre-service teachers was their experience in the undergraduate program. That is, senior students who were participated in the study had already completed most of the courses offered by the teacher education program. In other words, they were potential participants in order to have deep insight in what sort of knowledge, thought, understanding, and experiences were critical in understanding the conceptions of pre-service teachers on division of fractions.

#### *The Elementary Mathematics Teacher Education Program*

In order to graduate from the Elementary Mathematics Teacher Education (EME) Program, pre-service teachers must take mathematics and mathematics education courses, as well as physics, chemistry, English, Turkish, history, statistics and general educational science courses. The EME program emphasizes high order skills and professional development of the pre-service teachers. The graduates of the program are qualified as mathematics teachers in elementary schools from grade 1 to grade 8 (Middle East Technical University, 2003). The EME program mainly focuses on mathematics and science courses in the first and second years followed by the mathematics teaching courses in the third and fourth years. The program includes nine courses from the Department of Mathematics, four courses from the Department of Educational Sciences and 12 courses from the Department of Elementary Education.

Pre-service mathematics teachers engage in mathematics teaching and learning process mostly during their teaching practice courses and teaching method courses. School experience and teaching practice courses are offered at the second, seventh, and eighth semesters. The first school experience course is based mostly on observation of the classroom without involving active teaching. However, second school experience and teaching practice courses are generally based on both observation and practice. Pre-service teachers are expected to be actively involved in teaching and learning process during those courses (Middle East Technical University, 2003).

### **Instruments**

To gather information from the participants, following data collection tools were used: 1) A questionnaire related to pre-service teachers' representation models; 2) semi-structure interviews following the questionnaire.

In order to understand the representation models that pre-service teachers used to reason about their understanding on division of fractions, Division of Fractions Questionnaire (DFQ) was developed by the researchers. The questionnaire focused on assessing pre-service teachers' use of representations on reasoning their understanding of mathematical relationships on division of fractions. Specifically, pre-service teachers were asked to represent the following division expressions: fraction divided by a whole number, whole number divided by a fraction, and fraction over fraction. The items on the DFQ are as follows:

Use **one** representation/model to explain the given verbal and symbolic expressions

- 1) Four friends bought  $\frac{1}{4}$  kilogram of sweets and shared it equally. How much sweet did each person get?
- 2) Four kilograms of cheese were packed in packages of  $\frac{1}{4}$  kilogram each. How many packages were needed to pack all the cheese?
- 3) For,  $1\frac{3}{4} \div \frac{1}{2}$

After administering the DFQ to senior pre-service teachers, semi-structured interviews were conducted to obtain a more complete picture of the pre-service teachers' representation models on division of fractions. The sample questions on interview protocol are as follows:

#### Part III.

The researchers ask the following questions based on the answers given in the DFQ.

- How do you define division?

- Does division with whole numbers relate to the division with fractions? If yes in what aspects?
- Here in .....question you use the .....representation, what do you mean by.....”

Participant responses to questionnaire and interviews were all transcribed and videotaped.

## RESULTS AND DISCUSSION

For the first question, all of the pre-service teachers used partitioning division modeling (dividing a certain number of equal groups) while dividing the fractional part ( $\frac{1}{4}$ ) by the whole number (4). For instance; participant 14, as shown in figure 1, divided a whole into four and represented it as one-fourth. Then, one-fourth is further divided into four to distribute it among the four people and the amount that each person gets which is one-sixteenth is the result.

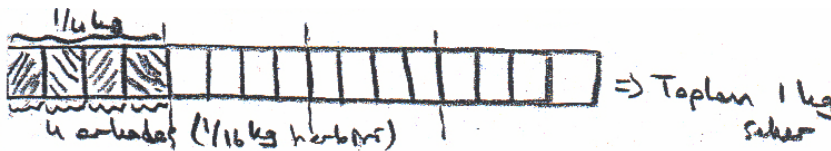

Participant 14:

### Figure1: Partitive division modeling of fraction over whole number (participant 14).

Within the partition modeling, fifteen pre-service teachers used rectangular area representation and only one participant used word problem to represent the division of one fourth by four.

In addition to the rectangular area representation and word problem, one pre-service teacher used pie chart as pictorial representation of the fraction over whole number as given in figure 2.

Participant 15:

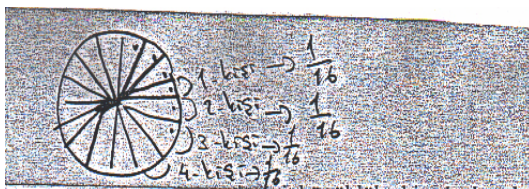

Figure 2: Pie chart representation of fraction over whole number ( $\frac{1}{4} : 4$ ) (par. 15).

During the interviews, all of the pre-service teachers participated into the study stated that it is easier to represent the division of fractions if the dividend is larger than the divisor (e.g.  $1/2 : 1/4$ ). On the other hand, they mentioned that if divisor is larger than dividend, it's not easy to explain the meaning of expression and even represent it. For example:

Participant 17: “ $1/4$  over four oops, it's different from division. I could not say how many fours are there in  $1/4$ . I mean it is not the same thing I confused. Since 4 is larger than  $1/4$ , it's difficult... I mean search for smaller number in larger number is easier but it's not easy to find larger number in smaller one.”

In the second question, where pre-service teachers were asked to represent division of whole number by fraction, all of them used measurement division modeling (forming groups of a certain size) contrary to the first question. For instance; in second question, participant 7 searched for number of one-fourths in one whole and then generalized this to the four wholes in solving the division problem.

Participant 7:

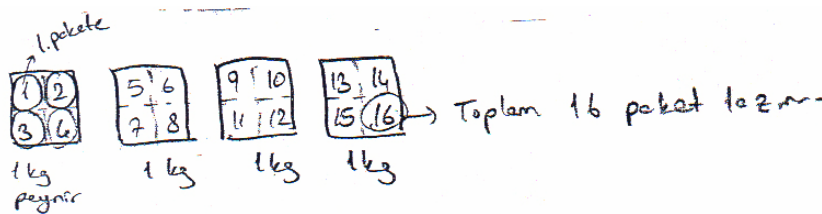

**Figure 3: Measurement modeling of whole number over fraction (participant 7).**

Within the measurement modeling, sixteen pre-service teachers used rectangular area model with symbolic representations to express the division of four by one-fourth. In addition, only one pre-service teacher used word problem with symbolic representation in order to denote the measurement modeling.

During the interviews, similar to the case above, pre-service teachers stated that if the dividend is larger than the divisor they could express the operation as finding the number of groups of divisor in the given dividend (measurement modeling). On the other hand, division is not easy to represent even not meaningful if dividend is smaller than the divisor. Additionally in the third question, where pre-service teachers were asked to represent division of two fractions, they said that division of fractions is same as the division of whole numbers. They added that division of two fractions could be defined by using measurement model of division. That is division of two fractions is finding how many groups of second fraction are there in the first one. For instance:

Participant 13: “Um it means same thing,  $4 \div 2$  means how many twos are there in four. We can combine the groups of twos and try to find four. Additionally, for

example  $\frac{1}{2} \div \frac{1}{4}$  means how many quarters are there in a half. Thus, the logic is same.”

Additionally, results revealed that most of the pre-service teachers who made generalization of division of whole numbers to division of fractions used examples where dividend is larger than the divisor. When they confronted with the opposite situation —divisor is larger than the dividend—, they had difficulties in justifying their arguments. Only few of the pre-service teachers made generalizations from whole numbers to fractions and represent the division operation successfully.

To sum up, results revealed that pre-service teachers’ inadequate knowledge on meaning of division of fractions influenced them in transferring this knowledge to the problems and to their representations, where they used limited representation models in reasoning their understanding while performing division of fractions. That is; their conceptions on primitive model of division operation (e.g. the divisor must be smaller than the dividend) inhibits their understanding on constructing relationship between division of whole numbers and division of fractions. Hence, they focused on specific models such as rectangular area representations that they were familiar from their elementary school. Pre-service teachers preferred to use the models that they were familiar from elementary school and they had difficulty in representing the given operations since they were not use to present the given expression by using different representational models.

Representations of concepts are corner stones of our mathematics classrooms (Akkuş-Çıkla, 2004; Ball, 1990a; McDiarmid, Ball, & Anderson, 1989, Kurt, 2006; Shulman, 1986). Representations are crucial for understanding mathematical concepts (Lesh et al., 1987). But, as stated above, in order to use appropriate representations, teachers should have deep knowledge on the concepts they are teaching (McDiarmid et al., 1989). Based on findings above, we could easily deduce that pre-service teachers’ inadequate conceptions on division of fractions limits their representations. Thus, findings of this research study extremely recommend the reconstruction of the courses offered to the pre-service teachers. In order to develop teachers who have rich subject and pedagogical knowledge, educators should offer courses that familiarize pre-service teachers with concepts and relationships through multiple representations. That is in their mathematics classes they should focus on using multiple-representation based environments where students directed to develop algebraic thinking through conceptual understanding (Akkuş-Çıkla, 2004). In addition, it is believed that mathematics educators, who seek alternative pedagogical instructions in their mathematics classes, should focus on using multiple-representation based environments.



## REFERENCES

- Ainsworth, S.E., Bibby, P. A., and Wood, D. J.: 2002, 'Examining the effects of different multiple representational systems in learning primary mathematics', *Journal of the Learning Sciences* 11(1), 25-62.
- Akkuş-Çıkla, O.: 2004, The effects of multiple representations-based instruction on seventh grade students' algebra performance, attitude toward mathematics, and representation preference. Unpublished doctoral dissertation, Middle East Technical University, Ankara.
- Ball, D. L.: 1990a, 'Prospective elementary and secondary teachers' understanding of division', *Journal for Research in Mathematics Education* 21, 132-144.
- Ball, D. L.: 1990b, 'The mathematical understandings that prospective teachers bring to teacher education', *The Elementary School Journal* 90, 449-469.
- Behr, M. J., Lesh, R., Post, T., and Silver, E. A.: 1983, 'Rational number concepts', in R. Lesh, & M. Landau (eds.), *Acquisition of mathematics concepts and processes*, New York: Academic Press, pp. 91-126.
- Carpenter, T. C., Lindquist, M. M., Brown, C. A., Kouba, V. L., Silver, E. A., & Swafford, J. O.: 1988, 'Results of the fourth NAEP assessment of mathematics: Trends and conclusions', *Arithmetic Teacher* 36(4), 38-41.
- Cramer, K.: 2003, Using a translation model for curriculum development and classroom instruction. Retrieved April 1, 2006, from [http://education.umn.edu/rationalnumber/project/03\\_1.html](http://education.umn.edu/rationalnumber/project/03_1.html)
- Fendel, D. M.:1987, *Understanding the structure of elementary school mathematics*, Newton, MA: Allyn & Bacon.
- Kieren, T., Nelson, D., and Smith, G.: 1985, 'Graphical algorithms in partitioning tasks', *The Journal of Mathematical Behavior* 4, 25-36.
- Kurt, G.: 2006, Middle grade students' abilities in translating among representations of fractions. Unpublished master's thesis, Middle East Technical University, Ankara.
- Lesh, R., Post, T., and Behr, M.: 1987, 'Representations and translations among representations in mathematics learning and problem solving' in C. Janvier (ed.), *Problems of Representations in the Teaching and Learning Mathematics*, New Jersey: Lawrence Erlbaum Associates, pp. 33-40.
- Mack, N. K.: 1990, 'Learning fractions with understanding: Building on informal knowledge', *Journal for Research in Mathematics Education* 21(1), 16-32.
- McDiarmid, G. W., Ball, D. L., & Anderson, C. W.: 1989, 'Why staying one chapter ahead doesn't really work: Subject-specific pedagogy', in M. C. Reynolds (ed.), *Knowledge Base for the Beginning Teacher*, New York: Pergamon Press, pp. 193-205.

- Middle East Technical University (2003). *General Catalog 2003-2005*. METU Printing Studio Press.
- Ministry of National Education [MNE].: 2002, *İlköğretim Okulu Ders Programları: Matematik Programı 6-7-8 (Elementary Curricula Programs: Mathematics Curriculum Program for Middle Grades)*, İstanbul: Milli Eğitim Basımevi.
- National Council of Teachers of Mathematics [NCTM].:1991, *Professional standards for teaching mathematics*. Reston, VA: Author.
- Payne, J. N.: 1976, 'Review of research on fractions', in R. Lesh (ed.), *Number and measurement*, Athens: University of Georgia, pp.145-188.
- Shulman, L. S.:1986, 'Those who understand: Knowledge growth in teaching', *Educational Researcher* 15(2), 4-14.
- Tirosh, D.: 2000, 'Enhancing prospective teacher' knowledge of children's conceptions: The case of division of fractions', *Journal for Research in Mathematics Education* 31(1), 5-25.

## A TASK AIMED AT LEADING TEACHERS TO PROMOTING A CONSTRUCTIVE EARLY ALGEBRA APPROACH

Nicolina A. Malara – Giancarlo Navarra

Department of Mathematics & SSIS, University of Modena & Reggio E. – Italy

*We tackle the issue of how teachers can be led to acquire conceptions and models of behaviours suitable to foster among pupils a constructive and linguistic approach to the algebra since primary school. We propose a model of structured task, as a connected set of questions addressed to teachers and centred at the analysis of activities and pupils' productions as well as on the design of classroom discussions. This task is made of operative and critical reflection activities, aimed at favouring the development of predictive and interpretive thinking by teachers, with respect to pupils' behaviours. We briefly report on some results of its use in teacher training.*

### INTRODUCTION

The socio-constructivist approach to the learning of mathematics has some important implications for teaching. The first is that the teacher image raises to a higher dignity: (s)he is a person with an individual interpretation of reality, and in particular of his/her teaching discipline, and of the aims and tools of its teaching. The second implication is that mathematics teachers have the responsibility of creating an environment that allows pupils to build up a mathematical understanding, but they also have the responsibility to make hypotheses on the pupils' conceptual constructs and on possible didactical strategies, in order to possibly modify such constructs. This implies that teachers must not only acquire pedagogical content knowledge, in Shulman's sense (1986), but also knowledge of interactive and discursive patterns of teaching (Wood 1999).

The complexities of classroom and school life oblige teachers to continually make decisions. These decisions do not only involve the solution of problems arising in the classroom, but foremost of their identification. Lester & Wiliam (2002, p. 494) stressed that "*the speed with which decisions have to be made means that the knowledge brought into play by teachers in making decisions is largely implicit rather than explicit*". Thus, it is important that the teachers are able to recognize and control it. This implies that they must be able to analyse their actions and reflect on the reasons that produced them.

Some scholars points out the need for teachers to reflect on their own practices (Mason 1990, 1998; Jaworski 1998, 2003). Jaworski (1998, p. 7) uses the following words to define the kind of practice that results from such a reflection, i.e. reflective practice: "*The essence of reflective practice in teaching might be seen as the making explicit of teaching approaches and processes, so that they can become the objects of critical scrutiny.*" Through reflective practice, teachers become aware of what they are doing and why: awareness is therefore the product of the reflective process.

We consider awareness as an essential element in the construction of a teacher's

qualified professional identity, and agree with Mason (1998), who emphasizes that what supports effective teaching is “awareness-in-counsel”. Thus it is extremely important that teachers undergo some preliminary training about the dynamics involved in the teaching and learning processes and particularly about aspects that influence decisional processes. The core objective in these teacher training processes is to make teachers aware that pupils are the main builders of their own knowledge.

In this perspective, on one hand teachers need to be offered chances, through both individual study and suitable experimental activities, to revise their knowledge and beliefs about the discipline and its teaching; on the other hand, they need to become aware that their main task is to make students able to give sense and substance to their experience and construct new knowledge by exploring situations and making links with familiar concepts and objects.

The actual attainment of these goals is extremely complex in the case of classical thematic areas, such as arithmetic and algebra, which suffer from their antiquity, and teaching of which is affected by the way they historically developed.

Teacher training referring to *early algebra* currently raises a great research interest: this disciplinary area became increasingly important in the last decades, as an answer to issues related to the teaching and learning of algebra. The work we present here concerns this content area and deals with activities and methods to educate teachers, aiming at a renewal of its teaching in a socio-constructive perspective.

### WHY EARLY ALGEBRA

One of the most heartfelt problems for secondary school teachers concerns difficulties students meet in their approach to algebra. The main reasons of these difficulties essentially lie in the heavy loss of meaning felt by students about the objects of study.

Since the ‘80s, research pointed to a way to modify this situation, underlying the need to promote since primary school a pre-algebraic teaching of arithmetic, cast toward the observation of numerical regularities, the recognition of analogies, generalisation and an early use of letters to represent observed facts.

Starting from the second half of the ‘90s, many theoretical and experimental studies were carried out on these aspects, mainly addressing 11-13 year-olds. Some of these studies stand out due to a theorisation of socio-constructive models of conceptual development; they emphasise the influence of the class environment on learning and promote the use of physical tools as means of semeiotic mediation, in the frame of a view of algebra as a language (Da Rocha Falcao, 1995; Meira, 1990, Radford 2000).

Since 2000 broad studies concerning teaching experiments, carried out at primary school level in relation to algebraic contents, appear (see for instance Carraher & al., 2000 or Carpenter & Franke 2001); some of these studies also concern the setting up of projects aimed at training primary school teachers on these issues (Blanton & Kaput, 2001; Brown & Coles, 1999; Dauguerty 2001; Menzel, 2001). Our *ArAl Project, paths in arithmetic to favour pre-algebraic thinking* locates within this frame (Malara & Navarra,

2003): it is a project that merges teacher training and innovation in the classroom.

### THE ALGEBRAIC BABBLING

In the traditional teaching and learning of algebraic language the study of rules is generally privileged, as if formal manipulation could precede the understanding of meanings. The general tendency is to teach the syntax of algebra and leave its semantics behind. We believe that the mental framework of algebraic thought should be built right from the earliest years of primary school – when the child starts to approach arithmetic – by teaching him or her *to think of arithmetic in algebraic terms*. In other words, constructing algebraic thought in the pupil progressively and as a tool and object of thought, working in parallel with arithmetic. It means starting with its *meanings*, through the construction of an environment which might informally stimulate the autonomous processing of that we call *algebraic babbling*. We hypothesize that there is an analogy between ways of learning natural language and ways of learning algebraic language. The *babbling metaphor* can be useful to clarify this point of view: while learning a language, the child gradually appropriates its meanings and rules, developing them through imitation and adjustments up to school age when he will learn to read and reflect on grammatical and syntactical aspects of language.

The perspective to start off the students with *algebra as a language*, continually thinking back and forth from algebra to arithmetic, is based on the negotiation and then on the rendering explicit of a didactical contract, in order to find the solutions of problems, based on the principle “*first represent, then solve*”. This perspective seems very promising when facing one of the most important issues in the field of conceptual algebra: the transposition in terms of representation from the verbal language, in which problems are formulated or described, to the formal algebraic language, into which relationships are translated. In this way, the search for the solution is part of the subsequent phase. From this point of view, *translating* sentences from verbal (or iconic) language into mathematical language, and vice versa, represents one of the most fertile areas within which reflections on the language of mathematics may be developed, even for the deep differences between the morphologies of the two languages. “Translating” in this sense means *interpreting* and *representing* a problem situation through a formalised language or, conversely, recognising a situation described in symbolic form. Such an innovative vision requires a process of authentic reconstruction of teachers’ conceptions in the field of mathematics and methodology, which is also among the objectives of the project itself.

### Methodological aspects in the approach to early algebra

The proposed situations in our approach to early algebra are developed within stimulating teaching and learning environments, but they are not easily manageable by teachers and involve several delicate aspects requiring specific competencies. As a consequence, those who wish to undertake innovative educational practices, need to deal with their own knowledge and beliefs, but also with a set of relevant methodological and

organisational aspects that actively support a culture of change. We shall now discuss some of these aspects.

### ***The didactical contract***

A continuous check of the clarity of the didactical contract implies that one constructs in pupils mathematical conceptions that will possibly favour a gradual formation of algebraic thinking, rather than give them technical skills. However, pupils must be aware that the essence of the contract is that they are protagonist in the collective construction of algebraic babbling. This means they should be educated to gradually become sensitive towards complex forms of a new language, through a reflection on differences between and equivalences of meanings of mathematical written expressions, a gradual discovery of the use of letters instead of numbers, an understanding of the different meanings of the 'equal sign', the infinite representations of a number, the meaningful identification of arithmetic properties and so forth. When the pupils realise that they are producing mathematical thinking and contributing to a collective construction of knowledge and languages, they make a variety of proposals, mostly interesting and non-trivial that altogether represent a common legacy for the whole class. It is here that the teacher should favour identification by pupils' paraphrases of a possibly correct translation, by selecting wrong, ambiguous, redundant, misleading or fancy translations.

### ***Mathematical Discussion and teacher's role***

The enactment of a collective discussion on mathematical themes leads to privilege metacognitive and metalinguistic aspects; pupils are guided to reflect on languages, knowledge and processes (like solving a problem, analysing a procedure), to relate to classmates' hypotheses and proposals, to compare and classify translations, evaluate their own beliefs, make motivated choices. In all this, the teacher should be aware of the risks and peculiarities of this teaching and learning mode.

The teacher plays a delicate role in orchestrating discussions. First, he/she must be clear about the constructive path along which pupils should be guided, and about the cognitive or psychological difficulties they might encounter. From a methodological point of view he/she must try to enact the various voices in the class harmoniously, inviting usually silent pupils to intervene, avoiding that leaders and their followers prevail and that rivalries between groups come out. Finally, he must help the class recognise what has been achieved as a result of a collective work involving everybody. He/she must learn to act as a participant-observer, i.e. to keep his/her own decisions under control during the discussion, trying to be neutral and proposing hypotheses, reasoning paths and deductions produced by either individuals or small groups. He/she must learn to predict pupils' reactions to the proposed situations and capture significant unpredicted interventions to open up new perspectives in the development of the ongoing construction. But this is a hard-to-achieve baggage of skills.

## THE PRESENT STUDY AND ITS METHODOLOGY

In these last years we addressed our research towards the individuation of methodologies and tools aimed at producing in teachers the mathematical/pedagogical competencies necessary to approach early algebra in a socio-constructivistic way.

Our research methodology is based on: 1) planning of didactical classroom routes with the teachers; 2) teachers' production of *diaries* (i.e. teachers' transcripts of audio-recordings of the classroom activities intertwined with their local or general comments and reflections); 3) joint (researcher & teacher) analysis of diaries; 4) constant sharing of the diaries among the teachers involved, writing of meta-comments, discussions and reflections.

Our research experience with the teachers made us aware of the difficulties they meet as to the design and management of whole class discussions (Malara 2003). This convinced us about the importance of the classroom processes analysis in order to lead the teachers to acquire the necessary competencies for the orchestration of the classroom discussion (activation of provisional thinking, listening and coordination of the students' voices, ability to take prompt decisions, ability to improvise, etc).

The collected documentation on the class episodes analysis -paradigmatic in highlighting the sharp correlation between the students' maths constructions and the teacher's sensitiveness in the discussion- brought us to elaborate a model of task we focus on.

### A MODEL OF TASK FOR TEACHERS: THE ANALYSIS OF CLASSROOM SCENES IN SEQUENCE

Our model of task gives teachers the chance to deal with the practice of constructive teaching 'theoretically', forcing them to focus on provisional and reflection-related aspects. The core of this task is to lead teachers to be able to analyse specific class processes and *reflect* upon these processes at different levels (development of pupils' mathematical construction, teacher's action, individual participation etc). The task develops along *Some Scenes (5 o 6)*, structured as a 'connected set of issues', and a *Final Reflection*. The scenes are based on excerpts of transcripts of one of our experimentations. Each *Scene* is a partially autonomous activity and 'realistically' sets the teachers in a class situation. It is composed of two sections: the first concerns the presentation of a classroom situation diary, and the second centres around questions related to the synthesis, in which teachers are asked: to tell their opinions about how meaningful the task proposed to pupils was; or to make hypotheses on pupils' productions and difficulties; or to interpret individual productions; or produce sketches of discussions aimed at comparing pupils' productions. As a whole, the set of Scenes put the teacher in front of a simulated classroom process.

Teachers are sequentially proposed Scenes at regular time intervals (on average 20-30 minutes): while they are working on the first Scene they do not know the second yet; when they elaborate on the second one they do not know the third one yet and so forth

up to the conclusion. After analysing the input proposed in the first part of the Scene, the teacher makes hypotheses about the class' reaction. In the subsequent Scene these hypotheses are compared with what actually happened and so forth up to the last Scene. At the end a global review of the work done is proposed, in order to reflect on: the process analysed from the point of view of mathematical construction and educational value for pupils; how meaningful the task is in terms of professional development. This kind of task developed with time and can be seen as the result of a research process. The first idea was born on producing interconnected e-learning worksheets for teachers in order to promote a constructive and linguistic approach to algebra, to which a transposition of these materials in a first version of the task for teacher workshops followed. The present version of the task has been proposed in workshops for teachers/trainees of junior secondary school since 2005. [1]

### AN EXAMPLE OF TASK IN EARLY ALGEBRA







We present a prototype of task made of six scenes (selected by a didactical process experimented in a 6th grade) and a final reflection. The process develops from an individual pupils' activity concerning the individuation of the rules and their algebraic formulation (see the first scene). This task was given to 45 teachers as the final test of a weekly 40-hour course on didactics of algebra, where didactical and methodological questions on early approach to algebra were faced with reference to the most recent research. Here, 20 hours were devoted to workshops dealing with similar tasks together with the analysis of excerpts from class discussions. The aim was to test the effectiveness of such task as an element of mediation between theory and practice and, more specifically, as a tool to set traenees 'inside' a virtual class, so that they can get aware of what it means to 'act in the moment'.

#### The first Scene

The class teacher presents the situation:

*Tilde likes chocolate cookies and finger biscuits, which she eats for breakfast every school day. She eats different quantities every day, but follows a rule she set.*

Then she shows a drawing with two ice cream spots which only hide the finger biscuits Tilde ate on Friday and the chocolate cookies she ate on Saturday.

Monday	Tuesday	Wednesday	Thursday	Friday	Saturday
					

At this moment the teacher gives a first task: Write down Tilde's rule in natural language.[2]

**Task for teachers:** 1. Carry out the task. 2. Give a short explanation about why searching for regularities is important in mathematics. 3. Discuss the instruments and/or strategies you view as the most efficacious to identify regularities.



## Working Group 12

### The second Scene

Pupils' sentences are classified by the class teacher and the most representative ones are written on the blackboard. Then the teacher opens up the discussion with the purpose of making the class decide what sentence best represents the rule followed by Tilde.

- (a) Tilde takes from finger biscuits the same number of chocolate cookies, she multiplies it by 2 and adds 1.*
- (b) She eats an odd number of finger biscuits and from 1 to 5 chocolate cookies.*
- (c) Chocolate cookies are always one more.*
- (d) One day she eats more and one day she eats less.*

**Task for teachers:** 4. Comment upon each of the four sentences written on the board concerning their consistency, completeness and efficacy with respect to the formulation of the regularity. 5. Imagine a plot for a discussion: opening, key steps and end.

### The third Scene

After a collective discussion, pupils agree on the choice of (a):

- (a) Tilde takes from finger biscuits the same number of chocolate cookies, she multiplies it by 2 and adds 1.*

The class teacher proposes 'Each of you may try to write (a) in other ways'

After a while some significant expressions written by pupils are reported on the blackboard:

- (a<sub>1</sub>) The number of finger biscuits is 1 more than twice the number of chocolate cookies.*
- (a<sub>2</sub>) The number of finger biscuits is twice plus 1 the number of chocolate cookies.*
- (a<sub>3</sub>) The number of chocolate cookies multiplied by 2, adding 1 equals the number of finger biscuits.*

Based on these sentences the teacher opens up a new discussion.

**Task for teachers:** 6. Comment upon the choice made by the class to send sentence (a). 7. Analyse the last three sentences, highlighting any possible difference with respect to the relational-procedural polarity. 8. Figure out a plot for a possible discussion.

### The fourth Scene

At the end of the discussion the class chooses sentence (a<sub>1</sub>); the remaining two are erased.

- (a<sub>1</sub>) The number of finger biscuits is 1 more than twice the number of chocolate cookies.*

The teacher gives a second task: (2) Translate Tilde's law for Brioshi in algebraic language [3]

**Task for teachers:** 9. Translate Tilde's law in more than one way. 10. Predict the possible translations by pupils.

### The fifth Scene

After an individual work, sentences are written on the blackboard (pupils' comments in brackets):

- |    |                        |                                   |
|----|------------------------|-----------------------------------|
| 1. | $1 \times 2$           |                                   |
| 2  | $a + 1 \times 2$       | (a = number of finger biscuits)   |
| 3  | $fb + 1 \times 2$      |                                   |
| 4  | $a \times 2 + 1$       |                                   |
| 5  | $fb + 1 \times 2 = a$  |                                   |
| 6  | $fb = ch + 1 \times 2$ |                                   |
| 7  | $a = b \times 2 + 1$   |                                   |
| 8  | $a \times 2 + 1 = b$   | (a = number of chocolate cookies) |
| 9  | $(a - 1) \times 2$     |                                   |

A discussion is enacted to choose the sentence that should be sent to Brioshi.

**Task for teachers:** 10. Comment upon each translation of Tilde's law, underlying their correctness/incorrectness, consistency, possible redundancies etc. 11. Predict what the class will possibly choose and related argumentation about the sentence they will send to Brioshi.

#### The sixth Scene

At the end of the discussion about the sentence to be sent to Brioshi, the following rule is chosen:  $b = a \times 2 + 1$ . The class teacher poses the problem 'Are we able to understand what happens on Friday and Saturday although ice cream spots hide part of the drawings?' Some pupils almost immediately use the formula correctly but other pupils are initially puzzled. This difficulty is overcome during discussion.

**Task for teachers:** 12. Is the rule sent out by the class the same you predicted at the end of the Fifth Scene? Is it different? Write down your comments on this. 13. Identify what the spots hide in the table illustrating the biscuits Tilde eats. 14. With relation to the question posed by the teacher, interpret the reasons underlying the widespread confusion in the class.

#### Final reflections

15. Write down a short reflection on the didactical situation you were asked to comment upon, also referring to a possibility of reproducing it in a hypothetical class of yours.

16. Write down a short concluding reflection on the structure of the whole set of tasks, mainly referring to its significance as model of task that may help trainee teachers explore what they learned both at mathematical and pedagogical level.

We cannot refer about the teachers' behaviour (we shall give some specific indications in the WG), so we limit ourselves to indicating some of the main results concerning the last questions of the task: 'the final reflections'.

### ABOUT THE TEACHERS' REFLECTIONS

Teachers' reflections gather around two aspects, often interwoven: value of the task as guiding instrument for the teacher; its complexity, difficulties and fears this generated.

The protocols show the undoubted usefulness of the task as a valid instrument to lead teachers, and especially those who have a little class teaching experience, to approach issues that characterise the teaching activity such as: a) prediction of pupils' behaviours; b) interpretation of their productions; c) setting up of discussions; d) sensitivity in grasping not only potentialities of pupils' contributions, but also obstacles produced by their distorted or partial views, often difficult to be identified. The structure of the task,

divided into scenes, is considered an effective classroom simulation to guide the teacher in a step-by-step involvement with the teaching sequence. Hypotheses about classroom-based actions are seen as very demanding tasks, still it is highlighted that the task is a powerful mean to force the teacher to compare predictions with the actual development of the class activity.

Protocols also show teachers' difficulties and fears concerning their own future abilities to implement constructive teaching. Difficulties mainly concern the design of discussion plots, the interpretation of and comment on formal written expressions, identification with students. Other fears concern not being able to understand pupils, confusing them, not being able to make them actually discuss, implementing a directive way of piloting the class, due to an unconscious stereotyped model of teacher.

Moreover, the protocols underline that teachers are aware of the cultural importance of expliciting their own development as teachers and open to collective sharing.

The processes in which they share new knowledge and new meanings are enacted at two different levels: with oneself, leading to reflections on the course's and the task's impact on one's own professional development and, more generally, on the 'renewed' relationship between theory and practice; with colleagues: by means of a peer to peer comparison about the task results and the things learned in the course, this leads teachers to become aware of the features of their own beliefs as well as of their way of conceiving the classroom activity. The latter is a fundamental step for a review of one's own attitudes and a change of unsuitable ones.

## NOTES

- 1 In order to become a secondary school teacher in Italy, one has to achieve a diploma from a two-year 'Scuola di Specializzazione all'insegnamento' (Specialization school for teaching) after graduating. But in Italy it is frequent that graduates are engaged as temporary teachers before and during their attendance at the Specialization School for teaching. For this reason we write here 'teachers/trainees' but in the following we shall simply write 'teachers'.
- 2 The question posed to the pupils is not easy: the text contains subtle logical elements, involving the meaning of both the universal quantifier 'all' and the adverb 'only', and uses spots to pose the problem of identifying unknown data. By examining the drawing, pupils must find a link between the number of finger biscuits and the number of chocolate cookies they see in the six boxes, trying to identify the relationship linking them. This is not a difficult task if one tries to express the number of finger biscuits as a function of that of chocolate cookies; much more difficult is to express the relationship starting from the number of chocolate cookies. Other two interrelated aspects, that should not be underestimated, concern the issues of the interval in which the single quantities may vary and generalisation of the law (the situation might induce a cyclic view of the process and inhibit a general view of the law). Moreover the Saturday day case arises some psychological and mathematical questions as to the number 0 for the lack of chocolate cookies under the spot.
- 3 In order to help pupils get to know the problem of the algebraic representation of verbally expressed relations or procedures, we invented a metaphorical character called Brioshi, who turns out to be a very effective support on conveying pupils aged 8-14 that it is necessary to respect the rules in the use of a symbolic language.

## REFERENCES

- Blanton, M., Kaput, J.: 2001, Algebraizing the elementary mathematics experience: transforming task structures: transforming practice on a district-wide scale, in Chick, E. & al. (eds), *12<sup>th</sup> ICMI Study 'The future of the teaching and learning of Algebra'*, 1, 87-95
- Brown L., Coles A. 1999, Needing to use algebra. A case study, *PME 23*, 2, 153-160
- Carpenter, T., Franke, M.: 2001, Developing algebraic reasoning in the elementary school: generalization and proof, in Chick, E. & al. (eds), *12<sup>th</sup> ICMI Study 'The future of the teaching and learning of Algebra'*, 1, 155-162
- Carraher, D., Brizuela, B., Schliemann, A.: 2000, Bringing out the algebraic character of Arithmetic: instantiating variables in addition and subtraction, *PME 24*, 2, 145-152
- Da Roca Falco, J.T.: 1995, A case study of Algebraic Scaffolding: from Balance to algebraic notation, *PME 19*, 2, 66-73
- Dauguerty, B.: 2001, Access to algebra: a process approach, in Chick, E. & al. (eds), *12<sup>th</sup> ICMI Study 'The future of the teaching and learning of Algebra'*, 1, 344-353, 87-95
- Jaworski, B.: 1998, Mathematics teacher research: process, practice and the development of teaching, *Journal of Mathematics Teacher Education*, 1, 3-31
- Jaworski, B.: 2003, Research practice into/influencing mathematics teaching and learning development: towards a theoretical framework based on co-learning partnerships, *Educational Studies in Mathematics*, 54, 249-282
- Lester, F. K. jr, Wiliam, D.: 2002, On the Purpose of Mathematics Education Research: Making Productive Contributions to Policy and Practice, in English, L. (ed) *Handbook of International Research in Mathematics Education*, LEA, Mahwah, NJ, 489-506
- Malara, N.A.: 2003, Dialectics between theory and practice: theoretical issues and aspects of practice from an early algebra project, *PME 27*, 1, 33-48
- Malara, N.A., Navarra G.: 2003a, *ArAl project: Arithmetic Pathways Towards Favouring Pre-algebraic Thinking*, Pitagora, Bologna
- Mason, J.: 1998, Enabling teachers to be real teachers: necessary levels of awareness and structure of attention. *Journal of Mathematics Teacher Education*, 1, 243-67
- Meira L. L., 1990, Developing knowledge of functions through manipulation of a physical device, *PME 14*, 2, 101-108
- Menzel, B.: 2001, Language conceptions of algebra are idiosyncratic, in Chick, H. & al. (eds), *12<sup>th</sup> ICMI Study 'The future of the teaching and learning of Algebra'*, 2, 446-453
- Radford L.: 2000, Signs and meanings in students' emergent algebraic thinking: a semiotic analysis, *Educational Studies in Mathematics*, 42, n.3, 237-268
- Shulman, L. S.: 1986b, Those who understand: Knowledge Growth in Teaching. *Educational Researcher*, 15, 4-14
- Wood, T.: 1999, Approaching Teacher Development: Practice into Theory, in Jaworski, B. et Al. (eds), *Mathematics Teacher Education: Critical International Perspectives*, Falmer press, London, 163-179

## **THE PROFESSIONAL DEVELOPMENT OF A NOVICE TEACHER IN A COLLABORATIVE CONTEXT: AN ANALYSIS OF CLASSROOM PRACTICE**

**M. C. Muñoz-Catalán, J. Carrillo & N. Climent**

*University of Huelva, Spain*

maria.cinta@ddcc.uhu.es; carrillo@uhu.es; climent@uhu.es

*This paper explores how the analysis of classroom practice by means of video, in collaborative contexts, promotes the professional development of a new entrant to primary teaching, Julia, with respect to mathematics. It focuses on recordings of two lessons given in consecutive school years, in which Julia works on the same topic, and the group session in which the first of these is analysed. Group reflection on her practice can be seen to provide her with an increased pedagogical content knowledge, which leads to a greater sensitivity towards aspects of teaching that she was previously unaware of. Certain barriers preventing this reflexive attitude from extending further into her practice are also considered.*

This paper forms part of a larger study in which we seek to understand the process of professional development (with respect to mathematics teaching) of a novice primary teacher, Julia, participating in a collaborative research project (PIC) (Muñoz et al., 2006). The PIC comprises two experienced teachers, two recently qualified teachers, two university researcher-trainers and a novice researcher. In order to clarify the context in which this study is immersed, we contribute its main features.

The group, which meets for three hours every fortnight, centres its interest on exploring ways that a problem-solving approach can benefit mathematics learning in the primary classroom. Each professional has their own interests and expectations which are linked to common objectives: development, of each member within their sphere (as teacher or teacher-trainer), and research, into both classroom practice and teacher-training. It is, then, a collaborative endeavour, adopting the principle of “working with, not working on” (Lieberman, 1986), and combining professional development with the construction of knowledge by means of research (although it should be noted that the teachers do not participate in the research tasks).

The work undertaken in the PIC is organised according to Ponte’s (1998) notion of professional development as opposed to training. Amongst the criteria established by Ponte in order to differentiate training and professional development, we highlight the following: is associated with the idea of attending multiple courses; it can be described by a flow from without to within whereby trainees assimilate knowledge and information provided for them; it focuses on what the teacher lacks rather than their potential; and it confers greater importance on the theory from which it derives and where it tends to remain.

The activities which the group undertakes are the result of jointly planning each session. No activity is realised if members do not consider it relevant for their

professional development. This relevance is constantly debated during the work of the sessions, therefore it can be said that responsibility for professional development is shared amongst the group (Day, 1993) and does not fall solely to the figure of researcher-trainer. In that respect, we have developed a shared understanding that professional development is not brought about through the acceptance of external rules or classroom recipes (handed down by the researchers), rather it is promoted only through reflection on practice and common professional activities.

Within the group, the researchers-trainers, as well as the experienced teachers, can be considered as ‘skilled collaborators’ in the sense of Day (1993) where they are ‘*special people, critical friends, trusted colleagues who have not only technical abilities but also human relating/interpersonal qualities and skills as well as time, energy and the practice of reflecting upon their own practice*’ (p. 87).

One of the activities which all the members particularly value is the joint analysis of recordings of lessons given by the teachers. There are two reasons for this: on the one hand, the teachers themselves consider it a highly valuable tool for their own professional development in that classroom practice becomes the focus of attention, and on the other hand, from a research perspective, it becomes a clear illustration of how our conceptualisation of professional development is intimately linked to reflection. All the teachers are videotaped during the year and a detailed analysis of video recordings is carried out within the PIC. In this paper we are interested in exploring the influence of Julia’s participation in the PIC on her professional development, focusing particularly on that of the joint analysis of lesson observations on her practice.

## **RATIONALE**

It is in the nature of teaching that it should present so many challenges. It is a complex activity to characterise, due to the great diversity of variables influencing the teaching-learning context, and the need to find immediate solutions. In-service training is required if the teacher is to respond to changing demands and ensure successful learning outcomes. In response, many studies have focussed on professional development. We consider this development can be represented as an increased understanding of teaching practice (Krainer, 1999; Climent, 2005), implying a commitment to reflecting on one’s own practice (Jaworski, 1998) such that reflection becomes both the measure and the means of the development.

Recognising and responding to this complexity is particularly difficult for newly-qualified teachers, whose entry into the profession can be described as a critical period of adaptation and learning. On the one hand, over-simplistic notions of teaching and learning will have to be revised, whilst on the other, such a recognition must not be allowed to paralyse the new teacher but rather stimulate the process of deepening understanding and improving practice.

Analysing teaching contexts via video recordings can be a valuable tool for professional development, in that classroom practice becomes the focus of attention.

It is also an eminently reflexive activity, whereby teachers directly question their own practice (Oliveira & Serrazina, 2002), thus initiating a reflexive dialogue (Schön, 1983; Goffree & Oonk, 2001) which leads them to reconstruct their understanding of the situation through their analysis. Beyond understanding specific situations, such analysis can be the starting point for more theoretical reflection, leading teachers to make vital connections between theory, practice and the development of practice knowledge (Goffree & Oonk, op. cit.). Amongst the many other advantages that video offers can be included the capacity to pause at critical moments, review key excerpts, and maintain a critical distance from events (Llinares & Krainer, 2006).

Collaborative projects between researchers and teachers (Climent & Carrillo, 2001) likewise offer clear advantages as they place great value on mutual respect and confidence within the group, and so promote a supportive atmosphere in which fundamental, critical and challenging exchanges can occur. Participating teachers develop a *professional perspective* which allows them give attention to other aspects of their teaching and consider them in different ways (Sherin & Han, 2004). The sheer variety of interpretations thrown up in the process of joint analysis makes the complex nature of education abundantly apparent, stressing the need to base interpretations on solid knowledge, and underlining the qualified nature of this knowledge (Sullivan & Mousley, 2001).

## METHODOLOGY

Our aim is to understand how the work of the PIC influences the professional development of a novice teacher. We focus on analysing classroom performance through the use of video recordings in order to gain insight into how collaboration with other professionals has the potential to bring about changes in the teacher's practice, and which factors promote or impede this influence.

As we are centring on an individual teacher's experience, the methodology we adopt is that of the case study (Stake, 2000). As mediators of her development, and working within the context of an interpretative paradigm, we build up an understanding of Julia's approach to key aspects of her practice (as mathematics teacher), and particularly the meanings and interpretations she develops over time.

We kept an open mind with respect to data so as to include maximum information, although we are aware that our interpretation of Julia's development depends on our *theoretical sensitivity* (Strauss & Corbin, 1994).

The study is, then, longitudinal and collects data from the first two years of Julia's teaching at a primary school. The collection techniques employed included classroom observation, teacher diaries, sound recordings of the PIC sessions, interviews and questionnaires. Here we focus on three information episodes<sup>1</sup>: two class recordings corresponding to two lessons (G7 and G27) from consecutive school years in which

---

<sup>1</sup> Understood as unitary chunks of information obtained from one data collection instrument at a specific date.

Julia covers the same section in the textbook, and the second PIC session (S8) in which the group analyses the first recording (G7).

The data were analysed in the order in which they were collected. For the PIC sessions we used the content analysis technique (Bardin, 1977), whilst for the recordings we followed Schoenfeld (2000). We first drew up a general scheme of the session, dividing it into episodes and sub-episodes (from macro to micro, taking into account the teacher's book as it was followed very closely). We then made a detailed analysis of each of the sections identified, and finally collated a summary of the most salient points emerging. In the case of G27 we were also interested in highlighting any changes observed, for which reason the analysis was undertaken in comparison with G7. We are aware, however, that such changes are not the exclusive preserve of the PIC as other factors were also influential.

We had the opportunity to work with Julia from the first year in which she was tutor to a group of pupils. She was keen on participating in the PIC from the start, and always showed great interest in her profession and in mathematics teaching, influenced by the fact that school life has always been a part of her experience, as her parents are teachers. The data referred to here correspond to her first two years in the profession, acting as class teacher to the first year of primary school (6-year-olds), at a school in the centre of Huelva (Spain), where the large majority of her pupils come from families of an upper-middle earning bracket. The two lessons analysed here (G7 and G27) – an introduction to the concept of symmetry – take place at similar points in both the academic year and the syllabus (derived from the textbook). The PIC group does not participate in the planning and execution of these lessons.

## ANALYSIS AND RESULTS

In the selected classroom recordings, the lesson in question concerns a section of the textbook presenting, in the initial activity, the concepts of whole and half, and in a second, that of symmetrical shapes. The first of these features drawings of five common foodstuffs, two complete and three half complete, and the activity requires the pupils to trace around the first two pictures and to complete the latter three (Figs. 1, 2 and 3). The second activity involves two shapes on graph paper for which the pupils have to draw a symmetrical half (see example in fig. 4):

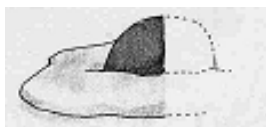

Fig. 1.



Fig. 2



Fig. 3

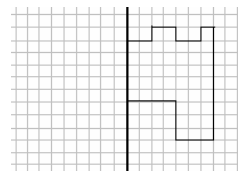

Fig. 4

### The first year

In the first year, at the start of the lesson, Julia gave out a sheet of paper to each pupil for them to fold in half and identify the two halves. Only two ways of doing this emerged, along the two axes of symmetry of the rectangular sheet. Summarising



what they had done, Julia made reference to the two equal halves that had been obtained: “If we cut it down here we’re left with two pieces the same because we cut it in half” [extract from G7]. She made frequent reference to the fact that the sheet they had started with was in fact half an A4 sheet: “Here’s half of the A4 sheet... half of the piece that I gave you all” [G7]. Afterwards, the pupils did the first activity of this section, tracing around the complete food items and completing the halves. While they were working on this, Julia noticed that the halves that the pupils were drawing to complete the items were much smaller than the originals, and so she gave a great deal of emphasis on making sure the two halves were the same size. She copied the example of the birthday cake onto the board, placing the candle the same distance from the axis. One pupil asked whether the term ‘the same’ referred to size: “*The same size?*” [G7].

In the second activity from the textbook, Julia began by asking whether anybody knew what a symmetrical shape was, and on not receiving an answer, explained: “a symmetrical shape is a shape which has two halves... the same” [G7]. As examples, she referred back to the food items from the previous activity, showing how they had become symmetrical shapes on being completed. With this decision she is reinforcing the association of the concept of half a shape with that of symmetrical half. To distinguish them, she could have used the example of the apple (Fig. 2) given that its symmetrical half should also have its stalk coming out of it, whilst a non-symmetrical half would not

She later explained how she implemented the earlier definition of a symmetrical shape (restricted to the likeness of the halves) to the case of the shapes on the graph paper. She drew a shape similar to those of the textbook on the board, the completion of which served as an example of what to do. Julia placed special emphasis on noting that if, for example, one part of the shape was at a certain distance to the right of the axis, then the pupils should count the same number of squares to the left and vice versa, saying *you have to imagine that you can fold the board in half and the two halves have to match*’ [G7]. This is the only reference in the whole lesson to the change of direction in the symmetrical half, concerning as it does an inherent aspect of the concept of symmetry. Julia gave more time to the practical application than to developing the concept itself, in large part because this enabled the pupils to complete the relevant section of the textbook, something of great importance for her. Once she had completed the example she again underlined that, by folding the shape along the line, *‘the two parts are exactly the same’* [G7].

### **Discussion in the PIC**

When this lesson recording (G7) was analysed in the PIC (S8), the group first allowed Julia to voice her own feelings about her performance and comment on any key points. Despite this opportunity, she did not identify any aspects that she felt could be improved. Indeed, she focussed uniquely on the pupils’ learning, noting that the concepts of whole and half were clear, as was that of symmetry: “I explained the

features of a symmetrical shape, the two halves the same, the line in the middle and what you've got on one side you have to put on the other side, and I think the pupils got that very clear" [Extract from S8]. She did, however, recognise the difficulty encountered in the second activity: "now that they had to do it on graph paper they weren't so sure about it [...] there are still children who need to work on their laterality." When asked whether she was aware that these practical activities could have been an ideal way of approaching the acquisition of the concepts, she was evasive and in response to a question by one of the researchers on her reasons for doing the second activity, she openly admitted that "*the graph paper one was to finish the book*" [S8].

The other group members then took the opportunity to express their thoughts, drawing attention to several points. First, with respect to the association made between the concepts of symmetry and half, other examples were offered of how to fold the paper in half without the resulting halves being symmetrical. The use of counterexamples was also suggested, in order to show examples which do not fit the definition, and in this way help the pupils to grasp the concept. Secondly, one of the researchers drew attention to the need to work on the differences between symmetrical shapes (with one or various axes of symmetry) and the symmetrical image of a shape with respect to a specific axis. Finally, Inés, one of the experienced teachers, suggested that, based on her own experience, "*you need to do activities which (...) lead them to intuit these things*" [S8]. She offered the following activity: the pupils make a blot on one side of a folded piece of paper, such that the blot reaches the fold, they then fold, press hard and unfold the paper to thus reveal a symmetrical shape. She emphasised the use of significant terms which suggest the concept, such as the matching of both halves, helps the pupils to learn and remember complex concepts such as this. The group concluded that "it is OK if the pupils need a lot of support or they don't learn something fully, but we shouldn't build on false premises" [S8].

### The second year

In her second school year, and still using the same textbook, Julia found herself working on the same topic. The lesson followed a similar pattern to that described in G7, though with certain modifications. Table 1 illustrates and compares the episodes of each lesson.

Episodes	G7	G27
<b>1. Folding half an A4 sheet in half and identifying both halves.</b>	Y	-A full A4 sheet is used in place of half a sheet, thus starting from a complete unit. -Greater attention is given to the fold: the sheet is cut along it after it has been coloured. -Greater attention is given to getting equal halves. - <u>The same</u> : the sheet is folded only in two ways.
<b>2. 1<sup>st</sup> activity.</b>	Y	-By asking questions, Julia encourages the pupils

<b>Identifying complete shapes and finishing half-completed shapes.</b>		to use the terms whole and half to describe their drawings. -The teacher relates this activity to that of the sheet.
<b>3. Symmetry using hand paints.</b>	NO	-Understanding the concept is given precedence over its practical application. This allows the definition to include not only the coincidence in terms of size, but also in terms of shape, of the two halves when these are folded along the axis of symmetry.
<b>4. Explaining the concept of symmetrical shapes.</b>	Y	- <u>The same</u> : the emphasis on the two halves being the same size, and referring back to the drawings in the first activity as examples of symmetrical shapes.
<b>5. 2<sup>nd</sup> activity. Instructions for doing the task.</b>	Y	<ul style="list-style-type: none"> <li>- At the start emphasis is placed in the instructions on matching both halves.</li> <li>-The pupils do the task with just the definition of a symmetrical figure, which Julia draws on to help them.</li> <li>-Julia notices that some are identifying ‘half’ with ‘symmetrical half’ and offers an example and counterexample: </li> <li>-The examples are offered after the pupils have begun tackling the task.</li> </ul>

**Table 1: comparison of the two classroom recordings G7 and G27**

## DISCUSSION OF RESULTS AND CONCLUSIONS

In this section we set out in what way we believe that the analysis of G7 in the context of the PIC influenced the way in which Julia approaches the work on the same topic in G27. The analysis of the PIC focuses on two aspects: on the one hand, Julia’s lesson-planning and considerations, and on the other, the influence her treatment of a specific mathematical area has upon the pupils’ learning.

With respect to the first of these aspects, in both S8 and other contributions to the PIC discussions, we note that Julia does not raise any questions about the broader aims of education and how these might relate to specific classroom activities. This lack of inquiry was clearly evident during the teaching practice stage of her teacher-training course (Muñoz et al., 2006 and derives chiefly from a strongly felt need to faithfully follow the textbook to its conclusion. This can be seen in her planning, which basically takes the form of considering how to set up the activities and how much time to spend on them: “*with the book, I have a look at what I’m going to cover, (...)*

*what I'm going to do before, what I'm going to do after, what we've already done on this topic and what isn't worth going over in too much detail as we've either already done it or are going to cover it in more detail later"* [S8]. In G27 Julia still follows the same system of planning, as, despite having questioned the appropriateness of the second activity (the graph paper activity) for assimilating the concept of symmetrical shapes, she continues to use it, albeit with a different approach in certain respects.

However, regarding the mathematical learning encouraged, we observed significant changes (in G27) as Julia gives attention to important aspects that she failed to consider before. It is worth noting the emphasis she places on understanding the concept of symmetry in lieu of the practical application in the form of the graph paper activity, and this can be seen in three decisions that she makes: first, there is the preparatory activity involving hand paints so that the pupils work on symmetry through manipulation and visualisation; secondly we can note the fact that she allows them to tackle the activity armed with just their understanding of the concept, without explaining how it might be put into practice with graph paper; and finally, of no less significance is her use of the concept of matching as a key term. Also of interest is her concern that the pupils understand the concept, as it is this that leads her to break off from the example she was expounding (an example similar to that in the textbook) so as to clarify the difference between 'half' and 'symmetrical half' by means of a counterexample. Whilst it would be naive to claim that this perceived change derives exclusively from this particular PIC session, or indeed any of the first year sessions, either individually or collectively, its influence cannot be denied. These incorporations underline how notions thrown up by the analysis of Julia's performance and the specific recommendations arising were assimilated, strongly suggesting that the collaborative context of the PIC helped to increase her pedagogical content knowledge with respect to the learning and teaching of symmetry.

However, certain limits remain. For example, she limits folding the sheet to just the two ways that the pupils are able to identify, thus allowing an association between half and symmetrical half to remain; in her talk she frequently mixes the terms 'half' and 'symmetrical half' ("when a shape has two parts which are exactly the same, it is called a symmetrical shape" – extract from G27 in which she defines the concept), although she is surprised afterwards when the pupils are confused; and she does not go into the differences between a shape which is symmetrical of another and a shape which is itself symmetrical. It is especially significant that she set up the activity using hand paints without instructing the pupils to ensure the drawing reached the fold, as Inés had suggested.

What might be the cause of these limits? On the one hand, it must be noted that Julia tends to heed those suggestions which are closely related to the textbook activities and which enable the pupils to tackle these with increased understanding (overall aims do not constitute a major concern for her). The textbook is her touchstone, and incorporations to her lessons tend to take the form of variations on the activities it

includes. On the other hand, a lack of reflection and true pedagogical thinking can still be observed, even in relation to the advice offered within the PIC. To a certain extent, it seems she locates the authority, or wisdom, to determine classroom practice jointly with the textbook and with the PIC, without thinking too deeply about what these authorities propose. Finally, one other barrier to her development as a teacher is represented by her relative complacency with her classroom management.

We believe that through analysis of her classroom practice in the PIC, Julia has widened her pedagogic content knowledge, and this has allowed her to develop greater sensitivity to aspects she was previously unaware of, giving her the confidence to make critical decisions in the course of the lesson itself, albeit for the moment closely linked to the analysis and suggestions of the PIC. In discussions within the group, beyond issues specifically related to the content of lessons under analysis, more general questions arise, such as what the objectives of mathematics teaching should be, how to plan lessons, or where to place the emphasis in the management of learning, in short, such questions as might motivate the development of a professional perspective of mathematics teaching. To a certain extent, Julia has begun to direct her attention towards key aspects of her practice, which can be interpreted as the initial signs towards developing the professional perspective to which Sherin and Han (2004) refer. Nevertheless, there do seem to be barriers preventing the reflexive attitude encouraged within the context of the PIC from extending to Julia's practice. Amongst these feature highly the lack of external support, the school culture, and a certain complacent attitude and lack of commitment to her own development.

Finally, we would like to underline that the analysis of classroom practice through video in collaborative contexts allows teachers to reflect on their teaching, enriching their perspective through the contributions of the group, and developing a better understanding of their practice. In brief, it encourages the dimensions of *reflection* and *networking* that Krainer (1999) establishes as a means of responding to current challenges to programmes of teacher training, given the tendency in teachers' habitual practice for *action* and *autonomy* to predominate.

## REFERENCES

- Bardin, L.: 1977, *L'analyse de contenu*, PUF, Paris.
- Climent, N.: 2005, *El desarrollo profesional del maestro de Primaria respecto de la enseñanza de la matemática. Un estudio de caso*, Tesis doctoral. Michigan: Proquest Michigan University. [www.proquest.co.uk](http://www.proquest.co.uk).
- Climent, N. & Carrillo, J.: 2001, 'Developing and researching professional knowledge with primary teachers', in J. Novotná (ed): *Proceedings of the 2<sup>nd</sup> Conference of the European Society for Research in Mathematics Education, Part 1*, Charles University, Faculty of Education, Prague, pp. 269-28.
- Day, C.: 1993, 'Reflection: a necessary but not sufficient condition for professional development, in *British Educational Research Journal*, 19 (1), p. 83-93.

- Goffre, F. & Oonk, W.: 2001, 'Digitizing real teaching practice for teacher education programmes: the MILE approach', in F.L. Lin & T.J. Cooney (eds): *Making sense of mathematics teacher education*, Kluwer Academic Publishers, Dordrecht, pp. 111-146.
- Jaworski, B.: 1998, 'Mathematics teacher research: Process, practice and the development of teaching', in *Journal of Mathematics Teacher Education*, 1(1), pp. 3-31.
- Krainer, K.: 1999, 'Teacher education and investigations into teacher education: A conference as a learning environment', in K. Krainer; F. Goffree & P. Berger (eds): *European Research in Mathematics Education I.III. On Research in Mathematics Teacher Education*, cap.1, Forschungsinstitut für Mathematikdidaktik, Osnabrück, pp. 13-39.
- Lieberman, A.: 1986, 'Collaborative research: working with, not working on...', in *Educational Leadership*, 43, pp. 28-33.
- Llinares, S. & Krainer, K.: 2006, 'Mathematics (student) teachers and teacher educators as learners', in A. Gutiérrez; P. Boero (Eds), *Handbook of research on the Psychology of Mathematics Education: Past, Present and Future*, Sense Publishers, Netherlands, pp. 429-459.
- Muñoz, M. C.; Carrillo, J. & Climent, N.: 2006, 'The transition from initial training to the immersion in practice. The case of a mathematics primary teacher', in M. Bosch et al. (eds) *Proceedings of the 4th Conference of the European Society for Research in Mathematics Education*, Sant Feliú de Guixols, Spain, 17-21 February 2005. Barcelona: FUNDEMI IQS, Universitat Ramon Llull. Pp. 1526-1536
- Oliveira, I. & Serrazina, L.: 2002, 'A reflexão e o professor como investigador', in GTI (org), *Reflectir e investigar sobre a prática profissional*, Lisboa, APM, pp. 29-42.
- Ponte, J. P.: 1998, 'Da formação ao desenvolvimento profissional', in *Actas do ProfMat 98*, APM, Lisboa, pp. 27-44.
- Schoenfeld, A.: 2000, 'Models of the Teaching Process', in *Journal of Mathematical Behavior*, 18 (3), pp. 243-261.
- Schön, D.A.: 1983, *The reflexive practitioner: How professionals think in action*, London: Basic Books.
- Sherin, M. G. and Han, S. Y.: 2004, 'Teacher learning in the context of a video club', in *Teaching and Teacher Education*, 20, pp. 163-183.
- Stake, R.E.: 2000, 'Case Studies', in N.K. Denzin & Y. Lincoln (eds), *Handbook of qualitative research*, Sage Publications, Thousand Oaks, C.A., pp. 435-454.
- Strauss, A. & Corbin, J.: 1994, 'Grounded Theory Methodology: An overview', in N.K. Denzin, & Y. Lincoln, (Eds), *Handbook of qualitative research*, Thousand Oaks, C.A, Sage, pp. 273-285.
- Sullivan, P. & Mousley, J.: 2001, 'Thinking teaching: seeing mathematics teachers as active decision makers', in F.L. Lin & T.J. Cooney (eds) *Making sense of mathematics teacher education*, Kluwer Academic Publishers, Dordrecht, pp.147-163.

# **FROM STUDIES OF COOPERATIVE LEARNING PRACTICES TOWARDS A MODEL OF INTERVENTION ON MATHEMATICS TEACHERS**

Angela Pesci

Department of Mathematics, University of Pavia

*Abstract. A model of intervention on mathematics teachers, consequence of experiences carried out through the cooperative learning modality, is described. The basic ideas of cooperative learning, viewed as a re-interpretation of the didactic system (teacher–pupil–knowledge–environment) are described. They welcome the urgency to restore, in the educative practice, the division between the disciplinary and the emotional aspects. The same urgency is underlined for the teachers also on the basis of some reflections about the complexity of their role in the cooperative model on the disciplinary, didactic, and relational level. This model of intervention on teachers is outlined, welcoming the necessity of taking care of both the disciplinary and didactic aspects and the more strictly personal ones.*

## **INTRODUCTION**

The model of intervention on mathematics teachers described in the final paragraph of this contribution is the result of a long history of my successive interventions on teachers. The first part of the history (1980-2000) was characterized by care for disciplinary and didactic aspects, usually on the frame of long-term research studies (Arzarello F, Bartolini Bussi M., 1998). When I realized I was not completely satisfied by the obtained results and I met the cooperative learning model, focused also on relational aspects, I understood it was the model for students I was looking for. (Pesci A., 2002). During the experiences carried out in collaboration with mathematics teachers, I realized that they suggested to me how to intervene on the teachers themselves and I arrived to elaborate a possible model. I have chosen, for this presentation, to follow the trace which brought me to the elaboration of the model, beginning with some details of cooperative learning modality and stressing the complexity of the role demanded to the teacher. Then, after the presentation of some teachers' reflections on their positive and negative perceptions following cooperative activities, the model of intervention on teachers is described, taking care, also for them, of the disciplinary, didactic and relational levels.

## **THE COOPERATIVE LEARNING MODEL**

Cooperative learning is a model of teaching – learning that works, in an explicit way, both with the disciplinary dimension and the affective and social dimensions of the relationships between the participants in the educative process.

In reference to the concept of didactic system (teacher – pupil – knowledge – environment, Brousseau G., 1986, Margolinas C., 1990) this model can be considered as one of its re-interpretations (Pesci, 2004). The relationships between the elements of the system are understood not only on the cognitive level, but also on the emotional, therefore taking account of the sensibility, the beliefs, the choices and the resources of the people involved in the educative process. The frame of reference is that of social constructivism, which emphasises discussion, negotiation of meanings, collaboration, and development of positive personal relationships (Ernest P., 1995, Bauersfeld H., 1995) and the concept of cognition is that formulated both as “situated cognition” (R. E. Nunez, 1999) with relevance to the context, and as “distributed cognition” (K. Crawford, 1997) with relevance to interrelationship and to sharing.

In Italy, the diffusion, discussion and application of this educational model was developed in the 80s, also promoted by the translation, in Italian, of several fundamental texts of the authors who have most committed themselves, at the international level, to promoting the culture of cooperative education (Cohen E. G., 1984, Johnson D. W., Johnson R. T., Holubec E. J., 1994, Sharan Y, Sharan S., 1992).

The innovative aspect of this teaching – learning model is the emphasis placed, in a symmetrical way, both on scientific investigation and on the development of social competence. The objectives to be reached are not played out only on the disciplinary plane, but also on the personal and social one, with the necessary attention to the quality of the relationships which are established amongst the people. The classroom teacher is therefore responsible not only for the cognitive level reached by his students in the discipline in which he is a specialist, but also for the personal wellbeing of his students and for the relational climate in his class. This implies that he takes care of developing his competence in an adequate way. This interconnection between the disciplinary plane and the emotional one, highlighted in a very explicit way by the cooperative learning model, is recognised today as unavoidable at every educational level, including that of adults. The need to heal the division between mind and body, between the rational and the emotional, which has characterised our culture for a long time, has been observed by now in all fields, from the medical to the pedagogical, psychological and sociological. That which neuroscience has confirmed, in recent years, about the close connection between emotion, sentiment and cognition (Damasio A.R., 1999) has further emphasised the necessity to reconcile, in the process of the construction of knowledge, reason and emotion (Polanyi M., 1958). Many studies, as is well known, are being developed exactly in this direction and the cooperative teaching – learning model interprets, in didactic practice, how to put this settlement into effect.

In order to better understand what is required of the teacher for an efficient in-class realisation of the cooperative teaching – learning model, it is useful to recall some basic ideas (Pesci A., 2002, Pesci A., 2004). Amongst the necessary conditions for cooperative learning there is, first of all, *positive interdependence*. The members of



the group must understand the importance of collaboration, that is, that individual success cannot exist without collective success and, by consequence, the failure of one single element of the group is a failure for everyone. Another important condition is the definition and the *role assignments* for each component of the cooperative group. The division of social and disciplinary competences amongst the members of the group encourages collaboration and interdependence, assures that individual abilities are utilised for the common work and reduces the possibility that someone refuses to cooperate or tends to dominate the others. It is essential the difference between the *status* of an individual and the *role* attributed to him. The *role* is assigned hierarchically by an authority, for example the teacher. On the other hand, the *status* is that which society recognises in a person; not only with reference to his intellectual gifts or his personal characteristics, but also to his social condition. Tied to the characteristics of *status* are the general expectations of competence, shared not only by the group, but also by the individual himself and this could be an obstacle in relation to the objectives which one desires to reach. One who is considered “low” level tends to intervene less than one who is considered “high” level and thus has fewer opportunities to develop his competence, further consolidating his “low” level. (E. G. Cohen, 1984). In attributing a *role* to a student, his autonomy is given full realisation; that is, he is authorised to take decisions, to evaluate and to check and this could overcome possible problems of low self-esteem or sense of inefficiency connected a low level *status*.

One essential component of the putting into effect of cooperative learning obviously has to do with *social abilities*. Effective management of interpersonal relationships requires that the students know how to maintain a leadership role within the group, take decisions, express themselves and listen, ask for and give information, stimulate discussion, know how to mediate and share, know how to encourage and help, facilitate communication, create a climate of trust and resolve possible conflicts. These abilities should be taught with the same awareness and care with which the disciplinary abilities are taught.

From what has been shown, it clearly emerges how essential and complex the classroom teacher’s role is. Along with the disciplinary competences, as has already been said, also the social competences take on decisive importance. The teacher, for example, must take decisions about the formation of the groups, develop in the students the social competences cited, check the adequacy of the work group, intervene with appropriate suggestions, encourage discussion, promote interventions and evaluate the results obtained. Also on the disciplinary side, the competence required is obviously not banal. Particular care must be given in the choice of the research situations to propose to students’ inquiry. Since work in collaboration requires ample time, it is desirable that the proposed questions are central to the development of mathematical thought and are, overall, adequate to the resources available in the class. It is evident that this choice can be suitably carried out only if the teacher has developed reflections on the epistemological meaning of the

mathematical contents to propose and moreover has a good knowledge of the students' competences.

The complexity of mathematics teachers' job, both on a cognitive and interpersonal level, is well known, just as the difficulty in managing interventions on teachers which intertwine theory and practice (Arzarello F., Bartolini Bussi M., 1998, Bartolini Bussi M., Bazzini L., 2003, Bazzini L., 1994, Javorski B., 2004, Lerman S., 2001, Malara M.A., Zan R., 2002).

In the frame of implementation of cooperative activities, the complexity of the teacher's role and the difficulties met by teachers also emerge, in the paragraph that follows, through the reflections of four people who, for several years have adopted the cooperative learning modality in their classes (the first experiences having been carried out in the 2000-2001 school year.)

### **THE EFFECTS OF COOPERATIVE LEARNING ON THE TEACHERS**

Our group has carried out several studies on the didactic experiences using the cooperative learning modality. Described in detail are the modalities of realisation which we have adopted in class, some methodological and didactical problems encountered and the solutions proposed (Pesci A., 2004). The complexity of the observation and evaluation of the pupils' competences, both at the disciplinary level and at the social level, has been highlighted and tools and modalities of observation have been suggested (Baldrighi A., Pesci A., Torresani M.C., 2003). Some experiences about specific mathematical contents have been analysed (Baldrighi A., Fattori A., Pesci A., 2004, Baldrighi A., Bellinzona C., 2004). The disciplinary and social evolution of some students with difficulties, observed after cooperative experiences, has been documented (Baldrighi A., Bellinzona C., Pesci A., 2005).

In this paragraph the attention is given to the teachers and in particular to the effects on themselves they have perceived following activities carried out in class in cooperative groups. For this purpose the following questions were asked (individually and written):

“Following the didactic experience that you carried out in class by means of the cooperative modality:

- which were the positive effects that you were able to note on yourself?
- and the negative ones?

I suggest you give short “quick” answers, that is, without thinking too much and without worrying about being exhaustive. Tell me the things that struck you the most, good or bad...”

The suggestion referring to the quickness of the answers had the objective of encouraging the selection, on the part of the teachers, of the peculiarities personally noted by them as principals of cooperative learning.

To the first question, observations emerge that regard the relation of the teacher both with the disciplinary contents and the didactic methodology, and finally with the social aspects. Here are some answers:

“Several times I had to critically rethink the disciplinary work to propose to the class, improving the quality and organisation of the didactic proposals. I also intensified my reflection on my behaviour in class” (M.C.)

“I found that the work is more stimulating, the communication with the class more intense and the objectives to be reached more easily shared.” (D.)

“I learned to see the pupils as “persons” and not only as “students”. (C. and M.C.)

“It was an excellent exercise to get me used to not suggesting the most efficient route to arrive at the solution.” (C.)

“I strengthened my ability to organise and manage an activity in which the students are the protagonists and not spectators of the class work. It helped me to be more active in the search for new proposals that stimulate the creativity of the pupils when confronting new concepts. I was more attentive to the uncomfortable situations and the difficulties present in a class and that cooperative work helps one to identify and confront.” (A.)

It stands out quite clearly that the modality of cooperative work, promoted in class by these teachers, led them to a work of choice and critical revision of the mathematical contents for the students, with a consequent improvement of the quality of their disciplinary proposal. It is getting them used to a different way of interacting with the students, not only orientated to identify what they know or know how to do in mathematics, but more open to see how each student is able to connect himself globally in the class environment and in the school environment. It forced them, therefore, to realise that social-constructive behaviour, with attention to personal and global growth of the students, described before, also forcefully promoting a continuous reflection on their behaviour in class and outside of class.

Moving on to the answers to the second question, there was a uniform answer regarding the sensation of incompetence in the management of the times, overall in class, and the perception of a work load that was too heavy. Here are some answers:

“I noticed that I’m not able to manage the times of the analysis phases, revision and successive collection of the work carried out by the children which often involves further developments and discussions both about the conceptual aspects and the relational questions.” (A.)

“Conditioned by comparisons with colleagues, I had the impression that the development of activities with the cooperative would have taken more time with respect to traditional teaching and therefore I sped up the rest of the programme!!” (C.)

“... A bit of anguish about the time, both in class and at home!!!” (M.C.)

“The activities to be proposed must be prepared very carefully and the situation to be managed is more ‘open’, thus much more demanding. Moreover, the times available are

always less than the needs and this brings some situations of anxiety and inadequacy.”  
(D.)

The sensations of anxiety, inadequacy and anguish certainly do not help the work of the teacher. In other occasions our group had underlined the difficulty in observing and evaluating students' social competencies, due to the lack of preparation in that field (Baldrighi et al., 2003). The many positive effects noted on the students, both on a relational level and on a disciplinary level, following cooperative learning experiences (Pesci A., 2002, Baldrighi et al., 2005), still impose to face the question in an explicit way. It seems necessary to take care of the teachers, planning interventions that deal, at the same time, with their disciplinary, didactic and relational preparation.

### **THE MODEL OF INTERVENTION ON TEACHERS**

It is evident, from what has been shown up to now, that the role required of the teacher for an efficient carrying out of the cooperative learning experience requires a complex of competences which are not always in their full possession. The *disciplinary competence* must always be revived by means of a continuous rethinking of the epistemological meaning of the contents and of the itineraries to be chosen and proposed to the students. The *didactic competence* often must be rethought in terms of knowing how to 'be' in class, with the students; very different from that required by a frontal lesson. The *relational competence*, which is crucial in cooperative work, must very often be constructed from nothing, through reflections and experiences which are not yet part, in a stable way, of the professional preparation of the teacher.

In this paragraph, with the aim to conclude with a possible model of intervention on mathematics teachers, I would like to describe briefly how I carried out interventions when I was asked to take experiences of cooperative learning to mathematics teachers (in service or in training).

The first phase of each encounter is characterised as an “autobiographical moment” and usually foresees both an individual reflection and a comparison with the others. Forming groups of from 4 to 6 participants, I usually distribute a sheet with a few simple questions for reflection on each one's professional history. After the reading and a possible comment from the group about what is required, each one writes his own individual response and then each one in the group reads it to the others. It is recommended that during this last phase that no-one makes comments or adds things. Perhaps at the end of the reading, they can ask questions to the others, avoiding, as best they can, making judgements. To promote the reflection on their own profession, I sometimes proposed the following questions:

“From my 'history' as a teacher: an episode to remember – an episode to forget – a moment of change – a wish that came true – a wish that did not come true”

The aim of the first phase is to aid the formation of the group, promoting both collaboration and differentiation and also developing, in each one, the attention, the

neutral listening and the welcoming of the other, including respect for the interventions and for the silences.

In the second phase of the encounter, the participants experiment on themselves the modality of cooperative work. I usually distribute the sheets that describe the five different roles planned ('orientated to the task', 'orientated to the group', 'memory', 'speaker' and 'observer'). I invite each one to choose a role and then to meet with the other participants with the same role. In this way, in each small group, they read and comment on the same profile; becoming aware of the various tasks that each role requires. It is also possible that modifications to the foreseen tasks arise; for example, simplifying them or choosing only some of them. At the end, I read, together with them, the various tasks (accepting the possible modifications, which each one has written on the sheets). Then briefly some instructions follow on how to carry out the activity. After the distribution of the disciplinary task and the work in groups, in which each one carries out the task, but at the same time plays the role he has chosen, there are foreseen: the reports from the speakers (on the mathematical results obtained), from the observers (on the degree of coverage of the role by each one), and finally a collective discussion. It is clear therefore that the both the disciplinary aspects, tied to the specific mathematics task, and the relational and social aspects, tied to the different roles taken on, are subjects for reflection. Therefore, in this second phase one is familiarised with this modality of work which is quite structured, but that still foresees some personalisation. As regards the choice of the mathematics task to propose to the participants, who are often from different scholastic orders, I always try to orientate myself toward simply tasks that still allow generalisations or more complex developments. The goal is that of posing relatively open questions which stimulate curiosity, the placing together of different resources and that can also be prototypes of class activities. Following is an example of a task in the arithmetic algebraic environment:

“If from the fraction  $\frac{m}{n}$  one passes to  $\frac{m+1}{n+1}$  does one obtain an equivalent fraction to the first? Greater than the first? Smaller than the first? Justify your answer”

Another example, in the geometry environment is:

“In the plane, the regular polygons are infinite. And the regular polyhedra in space? Why?”

The third phase of each encounter is a moment of reflection and discussion on what has been tried together. This can develop, depending on the cases, in different ways. For example, with deeper study on the reasons for the choice of cooperative learning as an educative modality or with discussions on the most appropriate kind of disciplinary task. More frequently, there is the statement on the part of those present on the different way of 'being' in class that such a methodology involves and the recognition of the importance of collaboration between colleagues (for discussions, comparisons, collection and exchange of material, etc.).

In conclusion, the basic idea is precisely that of creating, in each encounter, occasions for personal reflection and for dialogic inquiry, with the same spirit stressed in the project *Learning Communities in Mathematics* (B. Javorski, 2004), where the main objective is that both researchers and practitioners are engaged in action and reflection for mutual growing.

The model I propose here puts a more explicit accent in the necessity to intertwine disciplinary and methodological aspects with relational and social ones, going to develop, at the same time, the *disciplinary*, the *didactic* and the *relational* competence quoted before. With reference to relational and social aspects, I consider essential that a meaningful intervention on mathematics teachers (a) could give time and space to their reality as teachers in that precise moment of their professional history through the autobiographical discourse; (b) could constitute a direct experience of what is proposed, with wide possibility of dialogue with the other participants; (c) could be, in each case, attentive to the modalities of communication (verbal and non verbal, for instance favouring expressions through metaphors [1]). In this way, a process of reflection can be developed, on the part of the participants, on their own teaching discipline, on the (re)discovery of their own motivations to learn and of their own cognitive and metacognitive resources.

Direct experience could aide the acquisition of tools and modalities of reception of the other participants that can also have a spin-off in more positive relationships with colleagues, parents, students. It is also evident that such a model of intervention on teachers require adequate competences in didacticians, but even the simple recognition of the necessity of those competences could be an occasion for further collaborative studies and improvements.

### Note

1. On the importance of the metaphoric, autobiographical and non verbal discourse, there is ample reference in my contribution at CERME4 (A. Pesci, 2005), relative to an experience carried out with a group of mathematics teachers.

### REFERENCES

- Arzarello F., Bartolini Bussi M., 1998, Italian Trends in Research in Mathematics Education: A National Case Study in the International Perspective, Kilpatrick J, Sierpiska A. (eds.), *Mathematics Education as a Research Domain: A Search for Identity*, Kluwer, vol. 2, 243-262
- Baldrighi A., Pesci A., Torresani M., 2003, Relazioni disciplinari e sociali nell'apprendimento cooperativo. Esperienze didattiche e spunti di riflessione, *Atti Matematica e Difficoltà n. 12 "Osservare, valutare, orientare gli alunni in difficoltà"*, a cura di P. Longo, A. Davoli, P. Sandri, Pitagora, 170-178
- Baldrighi A., Fattori A., Pesci A., 2004, Un'esperienza di apprendimento cooperativo nella scuola secondaria superiore: il teorema di Pitagora, *L'insegnamento della matematica e delle scienze integrate*, Vol. 27b n. 2, 125-145

- Baldrighi A., Bellinzona C., 2004, Esperienze di apprendimento cooperativo: le equazioni di secondo grado, *L'insegnamento della matematica e delle scienze integrate*, Vol. 27A-B n. 6, 773-784
- Baldrighi A., Bellinzona C., Pesci A., 2005, L'evoluzione disciplinare e sociale di alunni in difficoltà durante esperienze di apprendimento cooperativo, *Atti Convegno Naz. Matematica & Difficoltà 14 "Alunni, insegnanti, matematica. Progettare, animare, integrare"* Davoli, Piochi, Sandri (Eds.), Pitagora, 104-109.
- Bartolini Bussi M. G., Bazzini L., 2003, Research, Practice and Theory in Didactics of Mathematics: Towards Dialogue Between Different Fields, *Educational Studies in Mathematics*, Kluwer, 54, 203-223
- Bauersfeld H., 1995 The Structuring of the Structures: Development and Function of Mathematizing as a Social Practice, in Steffe Leslie P. – Gale Jerry (Eds.), *Constructivism in Education*, Hillsdale, New Jersey, LEA, 137–158.
- Bazzini L., 1994, *Theory and Practice in Mathematics Education*, ISDAF, Pavia.
- Brousseau G., 1997 *Theory of Didactical Situations in Mathematics*, ed. and translated by N. Balacheff, M. Cooper, R. Shuterland, V. Warfield, Kluwer.
- Chiari G., 1997, Gruppi e apprendimento cooperativo: un'alternativa ai gruppi di recupero, *Scuola Democratica*, n. 1, 24-34.
- Cohen E. G., 1984, Talking and working together: Status, interaction, and learning, in P. Peterson, L. C. Wilkinson, M. Hallinan (Eds.), *The social context of instruction: group organization and group processes*, New York, Academic Press, 171-188
- Cohen E. G., 1994, *Designing groupwork*, Teachers College Columbia University, New York. Italian transl.: 1999, *Organizzare i gruppi cooperativi, Ruoli, funzioni, attività*, Erickson, Trento
- Comoglio M., 1996, Apprendimento cooperativo e insegnamento reciproco: strategie per favorire apprendimento e interazione sociale, in Vianello R., Cornoldi C., *Metacognizione disturbi di apprendimento e handicap*, Ed. Junior, BG, 77-105
- Crawford K., 1997, Distributed cognition, technology and chance, *Proceedings PME 23*, Vol. 2, 137-144
- Damasio A. R., 1999, *The Feeling of What Happens, Body and Emotion in the Making of Consciousness*, New York/S. Diego/London, Harcourt Brace & C.
- Demetrio, D., 1996, *Raccontarsi. L'autobiografia come cura di sé*, Cortina, Milano
- Ernest P., 1995 The one and the Many, in Steffe Leslie P. – Gale Jerry (Eds.), *Constructivism in Education*, Hillsdale, New Jersey: LEA, 459–486.
- Gallo Selva, A., Pesci, A., 2004, Taking into account metaphors, autobiographies and non verbal languages in the professional training of mathematics teachers, A. Rogerson (Ed.), *Proc. 7<sup>th</sup> International Conf. of the Mathematics Education into the 21<sup>st</sup> Century Project, The Future of Mathematics Education*, 119-122

- Javorski B., 2004, Grappling with complexity: co-learning in inquiry communities in mathematics teaching development, *Proceedings PME 28*, vol. 1, 17-36
- Johnson D. W., Johnson R. T., Holubec E. J., 1994, *The nuts and bolts of cooperative learning*, Interaction Book Company. Italian trans.: 1996, *Apprendimento cooperativo in classe*, Erickson, Trento
- Malara N. A., Zan R., 2002, The problematic relationship between theory and practice, in Lyn English (Ed.), *Handbook of International Research in Mathematics Education*, Lawrence Erlbaum Associates
- Margolinas, C., 1990, Una introduzione alle problematiche della didattica della matematica in Francia, *Quad. di Ricerca Didattica G.R.I.M.*, n. 1, Palermo, 5-25
- Nunez R. E., 1999, Embodied cognition as grounding for situatedness and context in Mathematics Education, *Educational Studies in Mathematics*, 39, 45-65
- Pesci A., 2002, Mathematics teachers and students: how can we improve the human side of their relationship?, *Proc. 5<sup>th</sup> International Conference "The Humanistic Renaissance in Mathematics Education"*, Palermo, A. Rogerson (Ed.) 11-19
- Pesci A., 2003, Could metaphorical discourse be useful for analysing and transforming individuals' relationship with mathematics?, *Proc. 6<sup>th</sup> International Conf. of the Mathematics Education into the 21<sup>st</sup> Century Project, "The Decidable and the Undecidable in Mathematics"*, Brno, A. Rogerson (Ed.), 224-230
- Pesci A., 2004, Insegnare e apprendere cooperando: esperienze e prospettive, *L'insegnamento della matem. e delle scienze integrate*, Vol. 27A-B n. 6, 638-670
- Pesci A., 2005, Mediation of metaphorical discourse in the reflection on one's own individual relationship with the taught discipline: an experience with mathematics teachers, *Proceedings Cerme 4*, <http://cerme4.crm.es/>
- Pesci A., 2006, Mathematics Teaching: Toward a More Human View, *Thinking Classroom Journal*, RWCT International Consortium, 20-25
- Polanyi M., 1958, *Personal Knowledge*, The University of Chicago Press, Chicago
- Sharan Y, Sharan S., 1992, *Expanding cooperative learning through investigation*, Teachers College Columbia University, New York. Italian trans.: 1998, *Gli alunni fanno ricerca, L'apprendimento in gruppi cooperativi*, Erickson, Trento
- Schön D. A., 1983, *The reflexive Practitioner*, Basic Books Inc., New York



## **TEACHERS' MATHEMATICAL KNOWLEDGE AND PEDAGOGICAL PRACTICES IN THE TEACHING OF DERIVATIVE**

D. Potari\*, T. Zachariades\*\*, C. Christou\*\*\*, G. Kyriazis\*\*\* and D. Pitta-Pantazi\*\*\*

\*University of Patras, \*\* University of Athens, \*\*\*University of Cyprus

*In this paper we investigate the nature of teachers' mathematics knowledge for teaching concerning derivative, relations between teachers' pedagogical practices and mathematical knowledge and factors that influence the development of teachers' knowledge. Our data comes from observing classroom teaching of nine teachers and from interviews with them. The results indicate that the quality of mathematics knowledge for teaching is characterized by teacher's conceptual understanding, procedural fluency, ability to make connections, an awareness of the role of mathematical symbols, ability to reflect on and extend the mathematical activity. These characteristics in connection to non traditional pedagogical practices can encourage students to participate actively and communicate mathematically.*

### **INTRODUCTION**

Teachers' mathematical and pedagogical knowledge have received increased research attention in recent years. These two aspects of teachers' knowledge are interrelated and have meaning mainly in the context of teaching. A notion that captures this complex relationship is what Ball and Bass (2000) call mathematics knowledge for teaching. However, most work under this perspective has focused on primary or early secondary education (Powel and Hanna, 2006; Stylianides and Stylianides, 2006). To examine teachers' knowledge in upper secondary or higher education has a special meaning as the mathematical knowledge becomes more multifaceted and the integration of mathematics and pedagogy is more difficult to be achieved. This paper is a part of a larger study which attempts to explore teachers' mathematical and pedagogical awareness in higher secondary education and more specifically in calculus teaching. Although, there is extended research on calculus education, this mainly concentrates on students' learning and not to the actual teaching practices and to the way that these affect students understanding. Through the study of teachers' practices and views about teaching and learning we attempt to investigate a) the nature of teachers' mathematics knowledge for teaching concerning a specific concept, the derivative b) relations between teachers' pedagogical practices and their mathematical knowledge and c) factors that influence the development of teachers' mathematical and pedagogical activity.

### **THEORETICAL BACKGROUND**

The notion of teacher knowledge has been recognized as an increasingly complex phenomenon (Cooney, 1999). A number of studies have attempted to describe this knowledge and it seems that there is some consensus in regard to three of its most

important elements: mathematical knowledge, knowledge of students' thinking and knowledge of mathematical pedagogy (Lappan & Lubienski, 1994; Even & Tirosh, 1995). Different concepts have been used to refer to these elements such as subject matter knowledge, pedagogical knowledge, pedagogical content knowledge (Shulman, 1986), knowledge about mathematics for teaching (Ball, 1991), or mathematical know-how (Boaler, 2003). Ball, Lubienski and Mewborn (2001) emphasize the need to investigate the way in which teachers' mathematical understanding affects their practice. They suggest that this should be investigated through the observations and analysis of actual teaching. Mason (1998) elaborates further the notion of teacher knowledge and talks about three levels of awareness, awareness in action, in discipline and in counsel both in mathematics and in mathematics teaching. To reach the last level is an ultimate goal in mathematics teacher education. In that case, teachers can offer reasons for certain actions and decisions, base these reasons in the discipline of Mathematics and Mathematics Education and also explain them to others. In addition to this, mathematical and pedagogical knowledge constitutes not only knowing-that, knowing-how, knowing-why but also knowing to act and knowing to act in the moment (Mason and Spence, 1999). In the case of mathematics, the last two elements are related to problem solving and to teacher's ability to recognise the appropriate method of approaching a particular mathematical situation. Concerning mathematics teaching, these elements are related to teacher's ability to evaluate teaching situations and to make on the spot decisions. Kilpatrick (2001) describes five strands that define mathematical proficiency: conceptual understanding, procedural fluency, strategic competence, adaptive reasoning and productive disposition. Boaler (2003) talks about elements of a rich mathematical activity such as creativity, inquisitiveness, making connections and viewing mathematical representations dynamically.

Mason's, Kilpatrick's and Boaler's work attempt to define what we consider as quality of mathematics knowledge which goes beyond procedural and conceptual knowledge and requires deep understanding of connections in mathematics itself and between mathematics and other situations. In our study, we draw elements from the above characterisation to form a framework for analyzing the quality of teachers' mathematical knowledge. We consider this knowledge linked to actual practice according to Ball's perspective, and we investigate it through teachers' actions and reflections.

## **METHODOLOGY**

The study is a qualitative research within an interpretative framework. The data was collected from three schools in Cyprus, from the mathematics lessons conducted by nine teachers. It is comprised by classroom observations, informal discussions before and after teaching and audio-taped semi-structured interviews with each teacher after the school visits (their duration was about one hour). The researchers observed and took field notes from three teaching sessions on derivative conducted by each of the nine teachers. Field notes were taken by two researchers and summaries were

constructed immediately after each observation from the combination of the field notes of the researchers. The summaries included a general description of the lesson and the substantial issues that emerged. Specific examples from the field notes were given as evidence to the identified issues. The interviews focused on a) teachers' experience concerning mathematics and mathematics teaching (eg. courses they had attended, inservice training, teaching experience) b) teachers' views about teaching and learning mathematics in general and calculus and derivative in particular and c) teachers' interpretations of specific pedagogical actions that were identified during the observations.

The data collected was analyzed systematically based on the grounded theory approach (Strauss & Corbin, 1998). The analysis of the summaries aimed at identifying elements of teachers' knowledge as they emerged from their practice. The emerged elements were discussed in terms of our conceptual framework of teachers' mathematical knowledge. The analysis of the transcribed interviews was initially done vertically for each teacher and then horizontally across the nine teachers in order to identify general patterns and relations among the different elements of the knowledge.

## RESULTS

### The nature of teachers' knowledge of derivative

The aspects of teachers' mathematical knowledge that were identified from our data were: conceptual understanding; procedural fluency; ability to make connections; ability to prove and justify; realization of the role of symbols; ability to reflect and extend the mathematical activity.

*Conceptual understanding:* The concept that was considered in the observed teaching sessions was the tangent of a curve. Most teachers gave as a starting example the tangent of the circle, an approach that was suggested in the school textbook, for reminding the students where they had met before this concept. Then, they introduced the tangent of a curve, they wrote its equation on the board without any further reference to the circle's tangent. As it was indicated from the interviews they did not seem to realize that the tangent of the circle is a particular case of the tangent of the curve. For example, Angela considered these as two separate concepts: "the concept of the tangent of the circle is not the same concept as the tangent of the curve...in the curve it is the tangent to a specific point". Thanos distinguished two types of tangents, one that has only one common point with the curve which is called "tangent of the curve" and another which has more than one common point and is called "tangent of the curve at a point". On the contrary, Georgia seemed to believe that there is possibly a relation between the tangent of the circle and the general notion of the tangent of a curve but she could not identify it. In the interview, she wondered: "Can we give a global definition for the tangent of a curve like in the case of circle? I have looked to find a definition as we say this is... but I haven't found it in the textbooks...". In the case of the tangent of the circle she recognized a global

characteristic property- exactly one common point – while in the general case of the curve the definition is of a local nature as it refers to a specific point. The above three teachers seemed to have a limited understanding of the concept of tangent and they could not identify relations between the tangent of circle and of curve. This is an indication that their mathematical awareness has not reached the level of awareness in discipline. However, some of them are aware of their limitations “I feel that I need to improve my understanding ... I sometimes wonder about some mathematical issues but I cannot give answers” (Georgia).

*Procedural fluency:* All teachers emphasized the calculation of the derivative of various functions in their teaching. However, few of them moved beyond the computational process and asked the students to justify their claims, to compare different solution strategies, to identify their advantages and disadvantages and to look for a general method. For example, one teacher (Michael) asked his students to identify the characteristics of the function they had to differentiate, the theorems they applied in this process and to find different solutions. He also encouraged them to discuss about the pros and the cons of these solutions. The above behavior indicates that this teacher’s procedural knowledge is flexible as it includes knowing what, how and why.

*Ability to make connections:* The connections that were observed were of three different types: among different representations, among different mathematical areas, among mathematics and other disciplines. However, in few teaching sessions “making connections” was a central teaching approach. Most teachers did not often use graphical representations in their teaching. Even in the case of tangent where all the teachers used the graphical representation to illustrate the concept and move to the formal definition, they used these two representations independently. Although, the topic of derivative provides the opportunity to make connections to other mathematical areas, as Euclidean and Analytic Geometry, and to other disciplines, as Physics, Finance etc, this opportunity was not taken over in the teaching. Only two teachers developed their teaching by using different representations of the same concept in a functional way and by encouraging students to build relations among different mathematical and scientific areas. For example, Michael introduced symbols that are used in physics to allow students to make connections and gives examples of applications of derivative to physics. The fact that most teachers did not make connections in their teaching possibly implies their own inadequacies to conceive such connection. However, as it appeared in the interviews, some external constraints had an effect on teachers’ decisions. Those external factors were the structure of the curriculum and time constraints. For example, Georgia supported strongly the importance of both using different representations and applications to physics but she could not overcome the curriculum constraints: “there is no connection at all between teaching science and mathematics, this is bad... some things had to be done simultaneously”.

*Ability to prove and justify:* Most teachers, according to the textbook, taught theorems without referring to the conditions under which the theorems are valid. For example, they formulated the rule of chain without taking into account whether the involved functions had derivative at certain points. Overall, their emphasis was given in the produced formula which should be memorized and used by the students to calculate the derivative of certain functions. A result of such approach was the appearance of some mathematical mistakes when the teacher demonstrated a proof or evaluated the validity of students' responses. An example of such mistake is while Angela explains to the class how we can find the derivative of logarithmic functions. She writes on the board the equivalence " $y=\ln x \Leftrightarrow e^y=x$ " and she asks the students to calculate the derivative  $y'$  by differentiating the relation  $e^y=x$  without examining whether the function  $y=\ln x$  is differentiable, which is a necessary condition for applying this process.

*Realization of the role of symbols:* The way that the teachers used mathematical symbols in the teaching indicated their own understanding of particular symbols and certain conceptions about the meaning they attributed to these. Their understanding is expressed through the way they relate the mathematical symbol to the mathematical object. Sometimes this relation was not accurate. For example, Barbara calculated on the board the derivative of the function  $y=2x^{-1}$  at  $x_0=2$  and she writes  $y' = -1/2$ . Here, she uses the symbol  $y'$  which denotes the derivative function to symbolise the derivative at a certain point which is a number. She also uses the same representation in other examples. Another problem that was observed was that the form of the symbol dominated over its meaning. Three teachers considered the symbol  $dy/dx$  as a fraction and in the chain rule they simplified the common terms. The role of symbols in learning and teaching mathematics was another dimension that emerged from our observations. Symbols were used as a means for recalling a certain formula (eg. the chain rule). Some teachers expressed the same mathematical object by using different symbols to promote students' understanding. Stephanie expressed the chain rule theorem by using three different notations while Michael asked the students to solve the same exercise by using different symbols for the variables.

*Ability to reflect and extend the mathematical activity:* In most of the observed teaching sessions there were no deviations from the planned mathematical tasks. Moreover, the mathematical activity remained at the level of action without further explorations at a meta-level. However, there were few cases where such explorations occurred. As we have mentioned before, Michael often asked "how" and "why" questions in his teaching. He also encouraged the students to make conjectures and think about some uncommon cases. In one episode, the teacher asked the students to find the equations of tangents of a parabola in two different points. The slope of one of these tangents by using the derivative was found to be zero. The teacher asked the students to interpret this: "A lot of you tend to believe that when you find the slope to be zero something is wrong... What is the special for a straight line with slope zero?" One student said that the line is parallel to x-axis and the teacher asked the class to

draw the parabola and the two tangents. A conjecture that was made during the discussion was that the slope of this curve changes in every point. The teacher asked the students to think further about the validity of this conjecture. He also encouraged them to think and interpret what is happening when the slope becomes infinity and he used the metaphor as a way to motivate them that “this is food for thought”.

### **Emerging relations between teachers’ mathematical knowledge and teaching**

The fact that teachers’ mathematical knowledge has an effect on their practices is something which has been reported by other researchers. From our data the main issue that emerged is that “effective” mathematics teaching occurred only in cases where teacher’s non traditional pedagogical practices coexisted with a rich mathematical knowledge for teaching. By effective mathematics teaching we mean teaching in a constructivist perspective where the teacher designs situations that allow students to construct mathematical ideas. The teacher builds his/her teaching on these ideas both in the planning and in the actual teaching (Schifter, 1998)

*Students’ participation and teachers’ mathematical knowledge:* A number of teachers encouraged students’ participation in their teaching where the students faced individually or in pairs a number of mathematical tasks. However, these tasks were mostly exercises without offering mathematical challenge and encouraging students’ creativity. Even in the case where some teaching materials were used to encourage participation, like worksheets, these acted as a means for classroom management. For example, Angela, Thanos, Barbara and Chris used worksheets in every lesson. These worksheets included required prior knowledge, main points of the new lesson and a set of exercises for practice and they were on the same line as the school textbook. In the interview, they said that they used these materials to save time. They could not see any other use of a worksheet that could offer learning opportunities to the students other than the mastery of skills and procedures. While introducing a new concept students’ participation was minimal. In this case, these teachers demonstrated on the board the process of defining the concept while the students attended the teacher’s exposition. When the teachers were asking some questions to evaluate students’ understanding, in most cases the students could not reply.

On the contrary, Stephanie who had a deep mathematical understanding, used worksheets with a different philosophy from the school textbooks. The supported mathematical activity focused on students’ conceptual understanding and the development of higher levels of mathematical thinking. A worksheet of Stephanie for the teaching of a new concept had as a starting point a problem aimed to initiate discussion. In the actual classroom this discussion led the students to define the concept and realize the reason for introducing it. The worksheet also had some questions for further clarification of the concept. Students’ participation during this teaching was active and substantial.

*Mathematical communication and teachers’ mathematical knowledge:* All the teachers had good relationships with their students and most of them were sensitive to

their students' emotional needs. They often attempted to create certain norms that would possibly allow a richer mathematical communication. Many teachers encouraged students to think about different solutions or how to prove certain formulas for calculating derivatives in case that they had forgotten. Nevertheless these two norms were not enough to allow the development of such rich communication. Angela, Panos and Barbara conceived these norms at a practical level - the students had to find the shortest solution in order to save time in the exams – and emphasized in their teaching the development of skills. On the other hand, Michael and Stephanie considered these norms as a way to develop students' understanding and extended the mathematical communication at a metacognitive level by asking the students to compare and evaluate their solutions. It emerged that the teachers who had a rich mathematical knowledge managed to transform classroom communication to a real mathematical communication that encouraged such productive dispositions.

### **The development of mathematical knowledge for teaching**

All the teachers who participated in our study had a university degree in mathematics. However, all considered these studies not particularly useful for teaching as they only gave them a general mathematical background. For example, Georgia characteristically said in the interview: “This knowledge did not help me teach but when you do more mathematics your thinking improves. I believe that my secondary school studies helped me more to teach than my university studies”. What they found useful for their teaching development was the induction courses they had attended as novice teachers. In these courses, they visited classes, they planned lessons and they also attended a number of courses focusing mainly in pedagogy. Three of them, Stephanie, Michael and Chris, also had a master's degree, Stephanie and Michael on Didactics of Mathematics and Chris on Educational Management. They all found these studies very useful to their career.

As it appeared from our study formal mathematical knowledge and theoretical pedagogical knowledge do not imply a quality of mathematics knowledge for teaching. The integration of these two aspects is a possible way to reach such quality. Stephanie and Michael developed such knowledge for teaching calculus in their post-graduate studies. During these studies they attended courses that integrated mathematical and pedagogical knowledge in specific content areas. They learned about research findings concerning students' thinking in these areas, they studied the role of different representations in learning and teaching specific concepts, they faced tasks where they had to investigate both mathematical and pedagogical ideas and they planned some teaching interventions. As it is indicated in the following two extracts Michael's and Stephanie's participation in a course on didactics of calculus with the above philosophy, improved both their mathematical and pedagogical awareness.

M: I learned about students' misconceptions and mistakes on the concept of limit. I also learned about ways to overcome these obstacles.

R: Didn't you see these mistakes in your actual teaching?

M: Yes, but while I was teaching I was doing things mechanically, even the concept of limit. I see now that understanding the concept helps in everything.

R: Do you believe that this course helped you improve your mathematical knowledge or your teaching?

M: I think both. (extract 1)

From extract 2 we see that teachers' awareness is the basis for considering alternative teaching approaches and for going beyond the curriculum and textbook framework.

"I knew only what I had to say, what the curriculum and the textbook had without understanding many things. After the course, I became more aware of these things."  
(extract 2, Stephanie)

This awareness can be an essential step towards teacher's creativity and autonomy.

Mathematics knowledge for teaching is content specific. This claim is illustrated by two examples. The pedagogical knowledge that Chris developed especially during his postgraduate studies helped him to think and try to implement alternative teaching approaches in his teaching. This had an effect on the way that the teacher interacted with the students. However, this knowledge by being independent from teaching and learning mathematics was not enough to develop teacher's mathematical and pedagogical awareness in the specific area of calculus teaching. The second example shows that Michael's pedagogical and mathematical awareness in calculus teaching could not be "transferred" automatically to other mathematical areas. Talking about relations between geometry and calculus, Michael thinks that "geometry is only formulas and if the students know these, they can be successful ... analysis has difficult concepts and understanding them is important for the students". This teacher did not have the opportunity, to extend his image about geometry beyond what is taught in schools as he had done for calculus.

## **CONCLUDING REMARKS**

Two basic elements of teacher knowledge are mathematics and pedagogical knowledge. When these two elements are separated and remain at a general level mathematics teaching does not share the characteristics of what Wilson, Cooney and Stinson (2005) describe as good teaching. The blending of mathematics and pedagogy is necessary for developing mathematics knowledge for teaching (Ball and Bass, 2000). However, this knowledge is content specific as the fact that the teacher has developed calculus knowledge for teaching does not mean that she automatically transforms it to other mathematical areas.



The quality of mathematics knowledge for teaching is characterized by teacher's conceptual understanding; procedural fluency with awareness of the applied rules, theorems, methods; teacher's ability to make connections among different representations of the same concept, among different mathematical areas and among mathematics and other disciplines; an awareness of the power and limitations of mathematical symbols; ability to consider the conditions under which a claim is valid as an essential step for proving the claim and finally to reflect on and extend the mathematical activity. The above characteristics allow teachers to offer rich mathematical experiences to the students when they adopt non traditional pedagogical practices. In this case students' participation and classroom communication becomes mathematically fruitful.

Both from our classroom data and the interviews, it emerged that mathematical experiences and pedagogical experiences cannot be two distinct forms of knowledge in teacher education. To develop teacher knowledge of the characteristics we have discussed in our paper is difficult to be achieved while teachers only participate in formal mathematics and pedagogy courses. Integrating mathematics and pedagogy is a way to develop teacher's knowledge towards effective teaching (Cooney, 1999; McMahan et al, 2006). This integration in teacher education can be realised through a number of tasks in which the mathematical activity is grounded in the context of teaching. For example, in these tasks the teachers can be asked to interpret students' strategies, to respond to a student's question or mistake, or to compare different teaching approaches. Such integrated approaches will help them to get a broader view of mathematics, to see its relevance to teaching and to recognise the need for their mathematical and pedagogical development.

## REFERENCES

- Ball, D. L. and Bass, H. :2000, 'Interweaving content an pedagogy in teaching and learning to teach: Knowing and using mathematics', in J. Boaler (ed.), *Multiple perspectives on the teaching and learning of mathematics*, Ablex, Westport, pp. 83-104.
- Ball, D. L., Lubienski, S., and Mewborn, D.:2001, 'Research on teaching mathematics: The unsolved problem of teachers' mathematical knowledge', in V.Richardson (ed.), *Handbook of research on teaching*, 4th ed., Macmillan, New York.
- Boaler, J.: 2003, 'Exploring the nature of mathematical activity: using theory, research and 'working hypotheses' to broaden conceptions of mathematics knowing', *Educational Studies in Mathematics*, 51, 3-21.
- Cooney, T.J.: 1999, 'Conceptualizing teachers' ways of knowing', *Educational Studies in Mathematics*, 38, 163-187.
- Kilpatrick, J.: 2001, 'Understanding mathematical literacy: the contribution of research', *Educational Studies in Mathematics*, 47, 101-116.

- Mason, J.: 1998, 'Enabling teachers to be real teachers: necessary levels of awareness and structure of attention', *Journal of Mathematics Teacher Education*, 1, 243-267.
- Mason, J. and Spence, M.: 1999, 'Beyond mere knowledge of mathematics: The importance of knowing-to act in the moment', *Educational Studies in Mathematics*, 38, 135-161.
- McMahon, T., Sztajn, P., Ghouseini, H. and Ball, L. D.: 2006, 'Working Session 7: Purposeful professional development for mathematics teacher educators', PME30, Charles University, Prague.
- Powel, A.B. and Hanna, E.: 2006, 'Understanding teachers' mathematical knowledge for teaching: A theoretical and methodological approach', in J. Novotna et al (eds.), *Proceedings of the 30th Conference of the International group for the Psychology of Mathematics Education*, Vol. 4, Charles University, Prague, pp. 369-376.
- Schifter, D.: 1998, 'Learning Mathematics for teaching: From a teachers' seminar to the classroom', *Journal of Mathematics Teacher Education*, 1, 55-87.
- Shulman, D.: 1986, 'Those who understand: Knowledge growth in teaching'. *Educational Researcher*, 15, 4-14.
- Strauss, A. & Corbin, J.: 1998, *Basics of Qualitative Research: Techniques and Procedures for Developing Grounded Theory*, Sage, Thousand Oaks.
- Stylianides, A. J. & Stylianides, G. J.: 2006, 'Content knowledge for mathematics teaching : The case of reasoning and proof', in J. Novotna et al (Eds.), *Proceedings of the 30th Conference of the International group for the Psychology of Mathematics Education*, Vol. 5, Charles University, Prague, pp. 201-208.
- Wilson, P. S., Cooney, T. J & Stinson, D. W.: 2005, 'What Constitutes Good Mathematics Teaching and how it develops: Nine High School Teachers' Perspectives', *Journal of Mathematics Teacher Education*, 8, 83-111.

## **PROSPECTIVE PRIMARY TEACHERS' USE OF MATHEMATICS TEACHING HANDBOOKS**

Tim Rowland  
University of Cambridge

*In the course of their one-year primary teacher preparation programme, UK students are advised to consult a variety of published 'handbooks' on mathematics and on elementary mathematics teaching. Little is known about which books they choose to consult, or for what purposes. In this paper, I report the results of a survey designed to find out how graduate, pre-service teachers at one English university use these handbooks. A brief coda to the paper summarises practices with regard to the use of such handbooks in pre-service primary teacher education in some other countries, as gleaned from discussions with participants at the CERME conference itself, when this paper was considered.*

### **INTRODUCTION**

I learned maths at school by rote. I have little or no understanding of why things are worked out in the way they are. ... It's also been 20 years since I attempted fractions/equations/long division etc. In short I'm having to start again in all areas. Three cheers for Derek Haylock! (Primary PGCE student, quoted in Goulding, 2002)

The knowledge base that underpins mathematics teaching is mysterious in its content and inter-relatedness. Three of the seven categories of teacher knowledge delineated by Shulman (1986) focus on knowledge specific to the subject being taught: subject matter knowledge (SMK), pedagogical content knowledge (PCK) and curricular knowledge. Teacher educators working with beginning teachers endeavour to enable their students to acquire such knowledge, or to be aware of the relevant knowledge that they already possess (SMK in particular) through their previous learning experiences. In the UK (England, specifically), we do this in part through our programme of lectures, seminars and workshops in the university. Yet, realising the limitations of what can be transmitted or constructed in this context, we refer our students to a range of books and journal articles that might add to their knowledge and understanding of mathematics and pedagogy.

My own theoretical position concerning the nature of teacher knowledge is heavily influenced by Shulman's conceptualisation, which seems to me to be insightful and expressed with clarity and elegance. At the same time, critics have argued that Shulman's framework is not sufficiently dynamic to allow for a non-absolutist view of mathematics (Meredith, 1995), that it is decontextualised (Stones, 1992) and presents a simple transmission view of teaching (Meredith, 1993; McNamara, 1991; McEwan and Bull, 1991). There is, nevertheless, in the objects of attention (books) in this paper, something of Popper's "World 3" – the world of tangible products of the human mind (Popper, 1972), where knowledge resides in various human artefacts, books in particular. Shulman's SMK and PCK constructs are useful in

considering the nature of these human knowledge resources as promulgated in texts written for teachers.

In the UK, most trainee teachers follow a one-year, postgraduate course (PGCE) in a university education department, although three-year or four-year undergraduate training is also possible, as well as various forms of ‘on-the-job’ apprentice-type training. All primary (elementary) trainees are trained to be generalist teachers of the whole primary curriculum, though they normally specialise in one curriculum area. The study reported in this paper was limited to Postgraduate Certificate of Education (PGCE) primary pre-service teacher education. Its purpose was to investigate *which* books the students used in their one-year course, *how much* they used them, and what they used them *for*.

## METHOD

A nine-item questionnaire (shown reduced in size in Figure 1) was distributed to a cohort of about 250 Early Years (EY, pupil age 4-7), Primary (P, 7-11) and Middle Years<sup>1</sup> (KS2/3, 9-13) PGCE students at one university, six months into their course. The questionnaire surveyed their use of seven selected books (referred to here as ‘handbooks’). These handbooks are all in widespread use in PGCE courses throughout England. They had been described and listed in the PGCE mathematics course guide, and tutors had commented on their different characteristics and strengths in class sessions. For example, whereas Derek Haylock’s blockbuster of a book addresses the teacher’s own mathematical knowledge and understanding with a view to classroom application, Julia Anghileri focuses more explicitly on arithmetic, pedagogy and relevant research. The book by Jennifer Suggate and her colleagues is sympathetically targeted at developing trainee teachers’ SMK, though each chapter concludes with “questions for the classroom”. Ian Thompson’s edited volume contains contributions on broader pedagogical issues and the national strategy for primary mathematics education.

163 returns were completed, comprising 19 EY, 108 P and 36 KS2/3 trainees. It can be seen that the first question was categorical, the last two are open response, and six asked for a Likert-type response on a 5-point scale.

---

<sup>1</sup> These students specialise in one subject, but all follow a ‘primary mathematics’ course focusing on Key Stage 2.

**PGCE STUDENTS' USE OF MATHEMATICS TEACHING HANDBOOKS**

The aim of this survey is to find out which mathematics teaching handbooks are being used, to what extent, and for what purposes.

The PGCE mathematics handbook lists several books that you might find useful. These include:

- **Anghileri**, J. (2000) *Teaching Number Sense*, London: Continuum.
- **Askew**, M. (1998) *Teaching Primary Mathematics*, London, Hodder and Stoughton.
- **Haylock** D. (2003) *Mathematics Explained for Primary Teachers* London: Paul Chapman
- **Thompson**, I. (ed) (1997) *Teaching and learning Early Number*, Milton Keynes: Open University.
- **Suggate**, J, Davis, A. and Goulding, M. (2001, second edition) *Mathematical Knowledge for Primary Teachers*. London: David Fulton
- **Koshy**, V, Ernest, P, and Casey, R, (2000) *Mathematics for Primary Teachers*. London, Routledge.
- **Mooney**, C., Ferrie, L., Fox, S., Hansen, A. and Wrathmell, R. (2000) *Primary Mathematics: Knowledge and Understanding*, Exeter: Learning Matters.

1. Which of the above books have you **used most** during the course? [indicate ONE BOOK by underlining: if you used two books equally, just choose one of them]

Anghileri Askew Haylock Thompson Suggate Koshy Mooney OTHER

If you chose 'other', what was the other mathematics text you used most? [a hint of the name of the author or the title should be sufficient]

2. Did you BUY or BORROW the book that you chose in Question 1? [underline one]

3. To what extent did you use the book to improve your mathematics subject knowledge? [underline one]

NOT AT ALL A LITTLE MODERATELY QUITE A LOT A LOT

4. To what extent did you use the book to find out about approaches to teaching mathematics? [underline one]

NOT AT ALL A LITTLE MODERATELY QUITE A LOT A LOT

5. To what extent did you use the book to fill out and enhance the Faculty mathematics lectures and seminars? [underline one]

NOT AT ALL A LITTLE MODERATELY QUITE A LOT A LOT

6. To what extent did you use the book when writing your Core Mathematics Assignment? [underline one]

NOT AT ALL A LITTLE MODERATELY QUITE A LOT A LOT

7. To what extent did you use the book to help prepare lessons on your school-based Professional Placement? [underline one]

NOT AT ALL A LITTLE MODERATELY QUITE A LOT A LOT

8. If you used the book a lot, or quite a lot, for some purpose different from those listed in Questions 3-7, what was that different purpose?

9. Please write here any comments that you may wish to add about the use of mathematics teaching handbooks

**Figure 1: The Questionnaire**

## RESULTS AND DISCUSSION

The students' responses to each item are summarised below, together with a short commentary on them.

The majority of students were able to identify one of the handbooks which they had used most (Table 1), although 14 responses (categorised as 'vague') picked out more than one book, or none.

Haylock	Anghileri	Vague	Thompson	Mooney	Other*	Askew	Koshy	Suggate
62	48	18	14	7	7	4	3	0

**Table 1: Most used handbooks (N = 163)**

\* mainly Anne Montague-Smith (1997) *Mathematics in Nursery Education*, David Fulton

About two-thirds of the students identified Haylock<sup>2</sup> or Anghileri as their most-used handbook. They are strongly advised by tutors to purchase their own copy of at least one handbook, and 60% had done so. Haylock users were twice as likely to have bought the book than those who opted to use Anghileri.

Own copy (%)		
ALL	HAYLOCK	ANGHILERI
60	84	40

**Table 2: Ownership of books as a percentage of those who named each book as their main resource**

The tables below summarise the students' responses to the items about the *extent* to which they had referred to their most-used handbook for particular purposes. Scores 1 to 5 in the left-hand columns correspond to least-to-most extent i.e. from "not at all" to "a lot". The other integers are **percentages** of the **sample** (N =163, column 2) or the relevant **subsets** (62 Haylock users and 48 Anghileri users). Responses to Question 8 were gratifying to the extent that they indicated that the questionnaire had successfully anticipated (in items 3 to 7) how these books were used (discounting responses such as "to fill space on my shelves"). Tables 3 and 4 relate to the enhancement of SMK and PCK respectively.

---

<sup>2</sup> The author's surname is, of course, a shorthand reference to the book listed in the introduction to the Questionnaire.

for SMK	ALL	HAYLOCK	ANGHILERI
1 (not at all)	8	3	15
2	35	29	27
3	33	34	35
4	21	29	21
5 (a lot)	2	5	2
mean <sup>3</sup>	2.75	3.03	2.69

**Table 3: Responses to Question 3**

for PCK	ALL	HAYLOCK	ANGHILERI
1	5	8	2
2	28	31	15
3	29	32	35
4	29	26	29
5	9	3	19
mean	3.09	2.85	3.48

**Table 4: Responses to Question 4**

The students seem to be fairly astute in recognising these different emphases (as mentioned earlier in this paper) in the ways that they use them.

Table 5 shows the extent to which students use the handbooks to ‘read around’ and fill out the content of their PGCE sessions in the university.

For enhancement	ALL	HAYLOCK	ANGHILERI
1	27	24	25
2	33	31	33
3	23	23	25
4	13	19	13
5	3	3	4
mean	2.31	2.47	2.38

**Table 5: Responses to Question 5**

This suggests that recourse to the books for course enhancement is, at best, modest. Some respondents to Question 9 indicated that they don’t have the time for such activities, or that they expect to find it more useful in their first teaching post.

For the PGCE course assignment, students are required to describe and analyse a mathematics lesson that they taught. Knowledge of relevant literature is valuable for

---

<sup>3</sup> The author recognises that averaging Likert-type scores is a commonplace but questionable practice.

the analysis, and students are expected to refer to it in their essays. Table 6 shows the extent to which they used handbooks such as these for this purpose.

Course assignment	ALL	HAYLOCK	ANGHLERI
1	7	11	0
2	13	18	4
3	24	29	21
4	37	31	48
5	18	11	27
mean	3.45	3.13	3.98

**Table 6: Responses to Question 6**

These responses suggest that the assessment requirements of the assignment motivate a number of trainees towards more intensive use of these handbooks. Anghileri, in particular, is perceived to be a relevant, scholarly resource for citation in the essay.

Table 7 concerns the students' use of these handbooks in preparing lessons during the school-based placements that account for half of the PGCE year.

Lesson preparation	ALL	HAYLOCK	ANGHLERI
1	50	45	54
2	29	29	23
3	14	15	21
4	4	6	2
5	2	5	0
mean	1.78	1.97	1.71

**Table 7: Responses to Question 7**

These responses might be thought to be disappointing when compared with those in Table 6. Haylock, Anghileri and the other texts are rich resources of what I and my colleagues have called knowledge for 'foundation' and 'transformation' (e.g. Rowland, Huckstep and Thwaites, 2004, 2005) in preparation for teaching. The existence of ready-made online 'unit plans'<sup>4</sup> may account for the lack of recourse to more fundamental sources of information and inspiration.

### Open Responses

Finally, some quotations from the open responses to Question 9 shed further light on the quantitative data. The respondent's PGCE age-phase and most-used handbook is given with of each quotation. The first two comments reflect the time and information overload experienced by many PGCE students:

---

<sup>4</sup> <http://www.standards.dfes.gov.uk/primary/mathematics> (accessed 3 January 2007)



No time to read any ... [P, Thompson]

I think a handbook will be useful when I am a qualified teacher ... with so much information being thrown at one [on the PGCE] another handbook isn't useful. [P, Mark Patmore, *How to pass the numeracy skills test*<sup>5</sup>]

A few, however, seem to have made time to read and be able to comment on several of the handbooks:

Of the recommended texts, I found Anghileri very accessible and informative, as were Thompson and Suggate for the assignment. Askew was informative for ideas relating to teaching various topics [KS2/3, Haylock]

Haylock is very good on subject knowledge (especially as a reminder for mature students). Anghileri is brilliant on counting/number, as is Thompson. I also bought Mooney, but found it less helpful [EY, Haylock]

Others were quite open about initially instrumental incentives:

I bought the book for the assignment [KS2/3, Askew]

Contrasting comments indicate the importance of sampling before buying, and that individual preferences inevitably differ:

I read all the Haylock book and found it very useful ... [KS2/3, Haylock]

I bought Haylock ... but actually it wasn't that useful. [KS2, Haylock]

I found Haylock extremely helpful and regret buying Koshy ... [KS2/3, Haylock]

Finally, a heart-warming antidote from an EY student to the commonplace complaint that university PGCE sessions are not sufficiently 'practical':

There should be more emphasis on the type of content these books contain during seminars/lectures and less time wasted on undertaking activities - give us the theory so we can learn to apply it! [EY, Montague-Smith]

## CONCLUSION

The findings of this survey suggest that, for a significant number of primary PGCE students, mathematics teaching handbooks such as Haylock and Anghileri become a significant resource for a variety of purposes during initial teacher training. At one extreme, represented by the student quoted at the beginning of this paper, they represent a lifeline. Others dip into them occasionally to enhance their SMK and PCK, and most students recognise that they need them when it comes to assignment essay writing. These books are perhaps neglected during school-based placements, although some students believe that they will be more beneficial once they are in their first teaching post. The challenge might be for PGCE tutors to integrate their use

---

<sup>5</sup> This text was not among those specifically recommended for the course. The 'skills test' interacts very little with the university-based teacher training, being an on-line assessment of basic numeracy which *all* teachers must pass for certification. For further details, see <http://www.tda.gov.uk/skillstests.aspx>

more thoroughly, yet more realistically, into the courses that they provide for beginning teachers, and for school-based induction tutors to give explicit encouragement to newly-qualified teachers to use them as a resource for teaching and a means towards professional autonomy.

**Coda**

In the context of international dialogue about teacher education at CERME5, conference participants kindly offered the following information about the availability, characteristics and use of comparable handbooks in several countries.

COUNTRY	PHASE	USE OF HANDBOOKS
Denmark	Primary	Practice similar to that in the UK. Several such books are available, use by students is optional.
Greece	Primary	Students must use a prescribed handbook (textbook) in their training. The book varies from university to university, and is provided free. The student teachers are also given a list of other handbooks but few student teachers use them.
Ireland	Primary	Such handbooks are not widely used. A lot of course materials are posted on the internet.
Portugal	Primary	Such handbooks do not exist for primary mathematics teacher education.
Czech Republic	Primary	Such handbooks do not exist for primary mathematics teacher education.
Spain	Primary	There are several such handbooks. One of the most popular and widely-used books is Castro (2001). This is a high-quality edited book, with chapters by various experts, each with a common structure.
England	Secondary	At one university, chapters from Haggarty (2002a, b) are prescribed pre-session readings.
Norway	Secondary	At one university, students are required to read Skemp (1986) and a Norwegian book about the teaching of mathematics in the autumn. In the spring they read Mason et al. (1982) and Eves (1990). The students do assignments to show that they have read them.

These brief details indicate the potential for further research, from a comparative perspective, including possible examination of the traditions and assumptions underpinning the recommendation and use of such handbooks.

## REFERENCES

- Anghileri, J.: 2000, *Teaching Number Sense*. London: Continuum.
- Castro, E.: 2001, (Ed.) *Didáctica de la Matemática en la Educación Primaria* (Didactics of mathematics in primary education ). Madrid: Síntesis.
- Eves, H.: 1990, *Introduction to the History of Mathematics*. Philadelphia: Saunders College.
- Goulding, M.: 2002, 'Primary teacher trainees' self assessment of their mathematical subject knowledge' Paper presented at the Annual Conference of the British Educational Research Association, University of Exeter.
- Haggarty, L.: 2002a, (Ed.) *Aspects of Teaching Secondary Mathematics: Perspectives on Practice*. London: Routledge Falmer.
- Haggarty, L.: 2002b, (Ed.) *Teaching Mathematics in Secondary Schools: A Reader*. London: Routledge Falmer.
- Haylock D.: 2003, *Mathematics Explained for Primary Teachers (2<sup>nd</sup> edn)*. London: Paul Chapman.
- Mason, J., Burton, L. and Stacey, K.: 1982, *Thinking Mathematically*. Wokingham: Addison Wesley.
- McEwan, H. and Bull, B.: 1991, 'The pedagogic nature of subject matter knowledge'. *American Educational Research Journal* 28, 316-334.
- McNamara, D.: 1991, 'Subject knowledge and its application: problems and possibilities for teacher educators.' *Journal of Education for Teaching*, 17(2), 113-128.
- Meredith, A.: 1995, 'Terry's learning: some limitations of Shulman's pedagogical content knowledge.' *Cambridge Journal of Education*, 25(2), 175-187.
- Meredith, A.:1993, 'Knowledge for teaching mathematics: some student teachers' views.' *Journal of Education for Teaching*, 19 (3), 325-338.
- Popper, K. R.: 1972, *Objective Knowledge*. Oxford: Oxford University Press.
- Rowland, T., Huckstep, P. and Thwaites, A.: 2004 'The knowledge quartet: Considering Chloe' CERME 4: Fourth Conference of the European Society for Research in Mathematics Education February 2005. Sant Feliu de Guixols, Spain.
- Rowland, T., Huckstep, P. and Thwaites, A.: 2005, 'Elementary teachers' mathematics subject knowledge: The Knowledge Quartet and the case of Naomi,' *Journal of Mathematics Teacher Education*, 8 (3), 255-281.
- Skemp, R. R.: 1986, *The psychology of learning mathematics*. Harmondsworth: Penguin.
- Shulman, L.: 1986, 'Those who understand: knowledge growth in teaching'. *Educational Researcher*, 15(2), 4-14.
- Stones, E.: 1992, *Quality Teaching: a sample of cases*. London: Routledge.

## **THE PROJECT WORK AND THE COLLABORATION ON THE INITIAL TEACHER TRAINING**

Leonor Santos, *Alexandra Bento*

Lisbon University, Secondary school José Afonso, Loures

*This paper focuses on the study of collaborative work in a context of initial teacher training where project work has been developed. We have chosen a methodology qualitative and interpretive in nature by doing study cases of two teachers in training. This study shows that the project work and the collaborative work are co-dependant. They represent important contexts of support, mutual help, exchanging experiences and development of a shared sense of responsibility, which are essential aspects in the first stage of professional incorporation. They also contribute to the teacher's professional development. Nevertheless, they require predisposition and the teacher's ability for self-exposure.*

### **INTRODUCTION**

In Portugal, initial teacher education follows several models, depending on the teaching level and the educational institution. The School of Sciences of the Lisbon University trains Mathematics teachers for the 3<sup>rd</sup> cycle of basic education (students from 12 to 14 years old) and for Secondary Education (students from 15 to 17 years old). During the first three years, the students only have Mathematics under the responsibility of the Mathematics Department; in the fourth year they have Educational subjects and Didactics of Mathematics, taught by the Department of Education; and in the fifth year they teach Mathematics at a school, with the supervision of a teacher from inside the school and two from the university (one of Mathematics and one of Didactics).

This article concerns part of a study regarding the fifth year of the initial teacher training, in which it has been developed in a continuous way a methodology of project work. Specifically, it aims at understanding the views of the future teachers involved towards collaborative work developed in the context of the project work and its implication on their professional development.

### **PROJECT WORK AND COLLABORATION**

The concept of project is polissemic. But, regardless of its many meanings, the word *project* can be translated as a behaviour of anticipating events, in the words of Boutinet (1990). In other words, it translates the growing human need for control over the surrounding environment, so that he can distribute and inhabit it in a better way.

By borrowing the concept of project work into the field of education, according to Boutinet (1990), the project's pedagogy comes as "a possible answer to the challenges put on the educational system" (p. 195) as two essential main

characteristics are connected to it: singularity/particularity and unity/idiosyncrasy. If we assume that all of the project work is built on personal interests and expectations, on former experiences of the team elements, it is unique because it arises from the participants' concerns on a particular situation within a social context and it is characterized by unity, for it is developed in a given space and time. We also have to consider the situations' complexity and uncertainty that motivate the elaboration of a project work.

As the project work is based on a methodology that is both focused on problems and that generates problems, the project work – within a context of professional problems resolution – is basically made of four fundamental stages: (i) the identification of the problem, which includes a deep knowledge of the context; (ii) the setting of a plan of action; (iii) the execution of this plan; and (iv) the generation of knowledge on the studied problem. The systematic reflection and the collaborative process (Railsback, 2002) developed in a practice context go through all of these stages and are, also, characterizing features of the project work.

Reflection and collaboration promote learning (Hargreaves, 1994; Zeichner, 1993), namely on the structure and development of professional knowledge. Sharing experiences, analysing and reflecting about practice may generate private theories from the teachers as they perform (Zeichner, 1993; Schön, 1991). Knowledge on these private theories involves analysing the beliefs and the concepts which are associated to it, allowing the teacher to reiterate, drop or modify them.

Specifically, the social context where these problem solving processes occur is essential. According to Huberman (1986), the group's cohesion level, which represents a catalyzing element, facilitates and accelerates the process of change in a group context of problem solving. Not individually and not in a big group, but in groups of two or three people, the teachers who are socially integrated in the group show more innovation and receptiveness to new ideas, which progressively strengthens changes in the relationships by developing a collective feeling of protection.

In the last decades, collaboration has been referred to as a favourable context for reinforcement of the trust which is necessary for innovation (Welch, 1996), as well as to improve effectiveness, reduce overload, situated certainty and opportunities to learn and continuous improvement (Hargreaves, 1994). Furthermore, it represents a valid alternative to professional development (Coronel *et al.*, 2003), both in its cognitive and emotional aspects (Hargreaves, 2001). However, Little (1990) warns us that not every concept of collaboration we can find in the literature propels change. Besides this important warning, we must still highlight the fact that, whether it is through *collegiality* (Hargreaves, 1994), or through *structural collaboration*, as Williams *et al.* (2001) oppose, what seems vital, namely in initial teacher training, is the way we look at the work – i.e. in a perspective of developing professional skills individually or in a perspective of favouring a professional culture based on collaborative work (Lima, 2003).

## METHODS

### Methodological options.

In this study, we followed a qualitative and interpretative approach (Bogdan & Biklen, 1982), with a study case design (Yin, 1989; Stake, 1994).

The study cases are two future teachers<sup>[1]</sup>, that constitute the whole group of student teachers in one particular school in the outskirts of Lisbon, who are going through their final year of graduation. They teach 10<sup>th</sup> grade classes from secondary school (16 year old students, non-compulsory education). One of the researchers, Alexandra Bento, was also the teacher educator that supervised these two future teachers at school.

The study used different data collection methods: three semi-structured interviews to each teacher (beginning, middle and end of the study), observation of the working sessions and classes, document analyses (written reflections and journals). The interviews and the moments of observation were audio-taped and transcript in full.

The data were submitted for content analysis. The different contents have been encoded and grouped by their meanings. In this way, the categories of the analysis were constructed as the data analysis was developed.

After the study cases were put into writing, they were returned to the teachers for their own analysis and validation. On the whole, the teachers agree with the personal and professional description they were given and did not want to change the written reports.

### Context for the study

In the beginning of the year, the teachers were asked if they wanted to do a training based on project work. They really seemed to take to this idea because, from the start, they say in quite a simplistic way, they want their training to be a “diverse and gratifying experience”. Three projects were developed, one in the first term and the other two in the second term. All the projects included two evaluation phases performed by the teachers, carried out in the middle and at the end of the project, and they were both preceded by written reports.

The first project, *Project of Tessellations*, comes naturally. As they read through the handbook, they did not like the way the tessellation subject was addressed. This is why they choose to develop an alternative approach, which includes tasks of exploratory nature for the students followed by reports, done especially outside of the classroom, and also a field trip which culminated in an exhibition for the parents and the whole school of the work they performed. The students also answered a questionnaire.

The second project, *Project of Functions*, is based on a similar idea: the wish to introduce an alternative method than the one adopted by the handbook. The teachers felt that the adopted method in the handbook does not provide continuity and follow

up to the topics addressed on this subject. This project also aims at resolving some imperfections that occurred in the adopted methods in class, in the Geometry subject during the first term. The teachers felt that, basically, these imperfections were of expository nature and produced some lack of motivation in the students. So consequently, unlike the first one, the second project was fully developed in the classroom. Nine work suggestions - that were essentially exploratory/investigational in nature - were designed and submitted to the students. The teachers made a folder, containing the work suggestions, that came with an "ID" (a set of characteristics of each tasks, such as strong points, limitations and suggestions for changes), and wrote an article for The Portuguese Mathematics Teachers Association Journal.

The third project, *Project The Training Teacher and the School*, comes as an answer for the need of school involvement, to contradict the idea of underestimation of the work done by the teacher in initial training on the school community's part. It includes a questionnaire answered by the Maths teachers group and a conference cycle.

## RESULTS

### Laura

Laura is 24 years old. Right from the start, she shows great sense of responsibility towards the tasks that come with the job. When she has problems or doubts, she has no problems in asking for help but she does not settle for explanations she does not understand fully. She always wanted to be a teacher. She mentions that Mathematics was her favourite subject. She chose teaching because she liked the school environment and the relationship with the students in particular. "I also enjoy the relationship with the students: to get to know them; to relate and work with some kids is very pleasing" (written reflection, 1<sup>st</sup> term) because she likes to learn and to be able to teach others. Her path through school is not marked by interaction with her colleagues. She didn't have the habit of studying together with other colleagues. It was only in the fourth year of her graduation that she realizes "the group's" most striking influence on her: "I didn't realize the importance of collaboration (...) It only happened more in methodology and it was then that I felt I learned the most" (2<sup>nd</sup> interview). She has expectations towards her training year: "I hope that it turns out to be a very positive experience, in which I can learn a great deal that can help guide me when I am alone with nobody to guide me" (1<sup>st</sup> interview).

For this teacher, doing the project works in which the training core was involved seems to have been important for establishing her views on collaborative work: "On the level of the projects we carried out, I emphasize collaboration" (2<sup>nd</sup> interview). For Laura, collaboration means group work, support, mutual help, security and sharing, as well as, a means for learning. In the beginning of the year, she mentions, in her journal, the fact that she has a number of issues she is worried about:

On the day before going to the school, all I could think about were the students. I wonder if they will like me. I wonder if I will be able to answer their questions. I wonder if the method I am going to follow is the best for learning. (journal)

The answer to all of these questions only came in time but, right from the first moment, it seems that one of the things that helps her overcome her difficulties in a more peaceful way is collaboration:

What has been helping me is the fact that I'm not alone in this situation. Having someone who shares these feelings and has the same doubts as I have, basically. I feel I can ask questions as absurd as they may seem. (journal).

The need for collaboration, as a synonym for mutual help, seems to be felt in the numerous tasks the teacher has to perform. The dynamics which are created in a work group – specifically, task division – helps to manage time more effectively and, subsequently, finishing the work at hand:

This term went by in a flash. I remember all of the concerns I had on the Christmas holidays. The work on functions for college, the conference cycle (which wasn't really set yet), supervised classes, like teaching the topic on functions... Part of that work has already been done and everything got done (...) once again thanks to collaborative work. (written reflection, 2<sup>nd</sup> term)

Despite acknowledging the potential of the performed projects, Laura describes them as complex works that drive the teacher to “take risks”. Having developed this work together with other people causes her to feel a shared responsibility which provides security for the teacher:

This work was somewhat complex. I confess that I wasn't prepared to take on a work of this nature. Knowing that I was not alone was what helped me. If I was alone I wouldn't have taken a chance, at least not in this year of training. (written reflection, 2<sup>nd</sup> term)

The need for sharing is felt on the level of the Mathematics topics. The Functions topic, worked on constantly in the *Project of Functions*, raises major fears in Laura, not because she lacks knowledge, but because she thinks it is a “world” in which one needs to analyse every concept very cautiously in order not to make mistakes:

The functions topic scares me a little. During the term's planning, I used to think: How am I going to teach this? I'll make mistakes for sure. I don't think I will be able to teach this subject.” Once again, working with Ana helped me unveil this subject. (journal)

For Laura, this concept of sharing is still associated with professional development. For this teacher, it seems only natural that, when we work with other people with both similar and different opinions from our own, we criticize and get criticized. She associates these aspects to the person's development and, subsequently, to the professional-self she carries:



Because it is much more productive and much more rewarding to work as a group, because we can discuss ideas (...) conveying knowledge and opinions enriches us and collaboration is a way to do so. (2<sup>nd</sup> written reflection)

She associates the development of her professional knowledge mainly with exercising teaching during the Project of Tessellations, in which she observed classes from both her colleague and her supervisor. Observing different obstacles and reactions from the ones she had seen in her class provides a learning situation:

The fact that this task is performed in other classes is a great thing for me because it allows me to get to know other obstacles that I don't come across in my class. (2<sup>nd</sup> written reflection)

At last, Laura's ability to take criticism from others also changed gradually. At first, as she was given criticism, she always felt the need to justify herself – as happened when she was asked about the teaching method she used, which was essentially focused on conveying information. Timing aspects, ability to use more common approaches which feature the handbook were justifying reasons pointed at that moment:

One has little time and knows that trying to do things differently will be harder (...) it wasn't an approach guaranteed for success, but it was the approach suggested by the handbook. (1<sup>st</sup> written reflection)

However, Laura changed this attitude – the dynamic of collaborative work developed in projects contributed largely to this:

Because it's very rich and productive to work as a group as we can discuss our ideas (...) we get criticized and criticize others as well, and that helps us evolve in this profession. To convey knowledge and views and so on can improve anyone and collaboration is a way to do that. (2<sup>nd</sup> interview)

## Ana

Ana is 23 years old. She sees herself as a fun person to be with and connects well with others. During the training year, she also proves to be a strong and determined person, who does not let herself down easily by less fortunate events, and fights for her goals. Besides looking very young, she is small and very thin, which provides that she blends in with the students. Teaching is her third choice. The desire to teach reflects in Ana from a very early stage because she is keen on helping others, although she does not look at teaching as a life choice: "I sometimes remember colleagues who did not understand and I went on playing smart, explaining things, but I thought it was funny" (1<sup>st</sup> interview). Ana enters the training year with little insight on what is ahead of her.

Ana looks at collaboration as natural work situation of the training year. Her distinctive features, mainly the fact that she is very sociable and communicative, favour her working with others' dynamics. During the school year together with her gradual introduction to the professional world, collaboration is seen as synonym for help, support and sharing: "Sometimes, I surprise myself because I feel the need to

tell everything that happens to me. I think I do it so I can have access to different opinions on my decisions” (journal). The teacher seems to feel that the fact that she is together with others helps her through the obstacles she encounters:

They behave so badly in class that, even when I reproached them, only a few of them would shut up (...) When I left the class it was good being able to talk to Alexandra and feel her support. (journal)

Ana seems to value this kind of support and sharing, not only regarding the work place, but also in a broader sense, concerning the teachers of Mathematics. On this matter, she talks about her first participation in ProfMat<sup>[2]</sup>.

The ProfMat days were great. I hope to come back every year (...) It is so good to feel that we are not alone. That there are many of us and that we care to share experiences. (journal)

Collaboration is seen by Ana as an element inherent to project work and projects may make up contexts which provoke collaboration:

In order to develop a project, there is usually a team and that team should work in collaboration (...) Maybe it's a good thing. If I ever feel unhappy, in a place where there is no collaboration, I'll say: I'm going to work on a project. (2<sup>nd</sup> interview)

Ana is aware of the isolation teachers usually work with. If someday she feels that she should work on a project, she will not put it aside because she does not have anybody to work with, but she points out that it will not be as productive as it would be if it were conceived and executed by a team:

If I feel like doing it and I think I'll benefit more from it by doing it (rather than not doing it), for instance, I feel I have a difficulty and I think it will be important to overcome by the project work, I think I'll do it. But I think that there (...) collaboration is very important and you'll have something to lose from. (2<sup>nd</sup> interview)

By the end of the school year, when Ana was asked about the importance of collaboration, she again mentions aspects such as, “exchanging experiences, diverse opinions, it carries a certain responsibility when it comes to dates, it allows distribution of work, it broadens horizons” (2<sup>nd</sup> interview). Besides these generic aspects, Ana mentions two others which are worth mentioning. One of them concerns the increase of her professional knowledge, particularly the augmentation of her repertoire in terms of approaches and methodologies that are brought to her through work sessions and class observing, which are scheduled activities for the projects' development:

I was able to share different approaches to the topics in order to help students understanding/apprehending. (written reflection, Project Functions)

(...) by observing both the supervisor's classes and my training colleague's classes, I can watch the strategies they use and, sometimes, use them for my own classes. (written reflection, 1<sup>st</sup> term)

The second aspect which collaboration seems to contribute to is setting the teacher's professional identity. On this matter, Ana mentions an incident related with one of the assessment meeting from her class, for which she was doing the documentation:

As soon as I reached the top (...) my car broke down. Because of this setback, I was late for the meeting (...) My colleagues were very nice about it. As soon as I got there they told me to relax and we would continue from there. The meeting went well.  
(journal)

The importance of working collaboratively with her peers leads Ana to consider performing it also with her students, providing them with opportunities for developing a major competence for their lives as adults:

I feel that group work is very important. Supposedly, life is made of collaborative work, team work. Therefore, we should forever work in this aspect. It's important for them to be able to listen to their colleagues, explain their ideas, taking responsibility for the group choices. (1<sup>st</sup> written reflection, Project of Tessellations)

## CONCLUSION

In the eyes of these teachers, project work and collaborative work seem to be strongly connected (Boutinet, 1990). One and the other are "two sides of the same coin". Adding further evidence to this, Ana says that despite being aware that probably in the future she is bound to find a work culture which is heavily based on individual work, she will still use project work in order to boost collaborative project work.

Collaborative work which was systematically developed in a group of three people allowed the setting for a mutual trust environment, of support and mutual help in the first stage of professional integration that requires facing and handling a number of problems which arise (Huberman, 1986). The risks involved in these situations were assumed by these teachers through a shared responsibility, which is an essential characteristic for developing successful and based change inside the school.

However, the project work and the context in which it was carried out also contributed to the teachers' professional development as it provided a learning tool they both recognized and benefited from. It helped them avoid mistakes, it provided gaining contact with everyday situations in the class of Mathematics and it broadened their repertoire of approaches to Mathematics topics.

We must emphasize that, in Ana's case, as she acknowledged the importance of collaborative work developed through her own experience; she also passed this concept to her students. In other words, the out coming results of a project work developed in a context of collaborative work affect, not only the group work who was involved in it, but also affect these teachers' students.

Nevertheless, this kind of work raises some problems. Where as for Ana collaboration was assumed naturally and continuously throughout the school year, in Laura's case, collaboration was not a part of her work habits. In the beginning of the school year, this teacher was not very receptive to criticism. It was only later that the

suggestions which were made to her started to be well accepted and seen as opportunities for learning. A pioneering context for both learning and professional exercise is not only made of advantages, but also presents the teacher with new challenges, as it demands from him the ability to self-expose and to deal with criticism which should be seen as advantage for his personal enhancement.

[1] The future teachers will be referred to as teachers.

[2] Mathematics Teachers National Conference, promoted by the Portuguese Association of Mathematics Teachers.

## REFERENCES

- Bogdan, R. & Biklen, S.: 1982, *Qualitative research for education: An introduction to theory and methods*. Allyn and Bacon, Inc., Boston.
- Boutinet, J. P.: 1990, *Anthropologie du Projet*. Presses Universitaires de France, Paris.
- Coronel, J.; Carrasco, M.; Fernández, M. & González, S.: 2003, Qualities of collaboration, professional development and teaching improvement: an experience in the university context. *Journal of Education for Teaching*, 29(2), 125-147.
- Hargreaves, A.: 1994, *Changing teachers, changing times*. Cassell PLC, London.
- Hargreaves, A.: 2001, The emotional geographies of teachers' relations with colleagues. *International Journal of Educational Research*, 35(5), 503-527.
- Huberman, M.: 1986, *Como se realizam as mudanças em educação*. Editora Cultix, São Paulo.
- Lima, J.: 2003, Trained for isolation: The impact of departmental cultures on student teachers' views and practices of collaboration. *Journal of Education for Teaching*, 29(3), 198-218.
- Little, J. W.: 1990, The persistence of privacy: Autonomy and initiative in teachers' professional relations. *Teachers College Record*, 92(4), 509-536.
- Railsback, J.: 2002, *Project-based instruction: Creating excitement for learning*. Northwest Regional Education Laboratory, Portland.
- Schön, D.: 1991, *The reflective practitioner*. How professionals think in action. Maurice Temple Smtih Ltd, Great Britain. (first edition 1983)
- Stake, R.: 1994, Case studies, in N. Dezin & Y. Lincoln (Eds.), *Handbook of qualitative research*. Sage Publications, London, pp. 236-247.
- Yin, R.: 1989, *Case study research: Design and methods*. Sage Publications, London.
- Zeichner, K.: 1993, *A formação reflexiva de professores: Ideias e práticas*. Educa, Lisboa.

- Welch, M.: 1996, Collaboration: Staying on the bandwagon. *Journal of teacher Education*, 49(1), 26-37.
- Williams, A.; Prestage, S. & Bedward, J.: 2001, Individualism to collaboration: The significance of teacher culture to the induction of newly qualified teachers. *Journal of Education for Teaching*, 27(3), 253-267.

## **Primary teachers' attitudes towards and beliefs about mathematics teaching: the collective culture of one English primary school.**

**Judy Sayers**

*The University of Northampton, United Kingdom*

### **Abstract**

*This paper reports on an exploratory investigation of one primary school's teachers' conceptions of and attitudes towards mathematics and its teaching. A significant disparity in the student's attainment on mandatory tests led the headteacher to contact his local university with a view to identify explanatory factors for this anomaly. A questionnaire study of all the teachers in one primary school was conducted to identify their attitudes and beliefs about mathematics and mathematics teaching. Initial findings suggest that, despite variation in teachers' beliefs about mathematics its teaching and the frameworks within which they operate, their comments about their teaching were indicative of similar constrained and risk-averse practice, suggesting a school's specific, culturally-defined professional identity.*

### **Introduction**

The study reported here was conducted in an English primary school which had been experiencing difficulties with the mathematical achievement of its 430 children aged 4-11 years. In particular, school data showed that mathematics learning and teaching in the age group 7-11 years appeared to be stronger than that in the age group 4-7 years and the headteacher was interested in finding out why this might be.

The school has a teaching staff of fourteen and serves a large village of varied socio-economic groupings in central England. In respect of primary education the mandatory assessment regime in England tests all children at ages 7 and 11. On such tests the school can be seen to be successful with 100% of children achieving expected levels or above at age 7 and 99% at age 11. However, at age 11, 40% of the cohort achieved above the national average compared with only 25% at age 7. It was this disparity that led to the headteacher's inviting us to undertake an exploratory project in his school.

### **Theoretical Framework**

Evidence from large scale international studies (TIMSS) (Beaton et al 1996) and its repeats (Mullis et al 2000, 2004), and OECD (2001, 2004) indicates that children's mathematical attainment is greatly determined by the country in which they live. Moreover, Travers et al (1989) noted that differences between the attainment of different countries may be due to distinctions between systemic ambitions (the intended curriculum), what and how teachers teach (the implemented curriculum) and what students actually learn (attained curriculum).

According to research, a major influence on the ways in which teachers implement the intended curriculum concerns teachers' beliefs about the nature of mathematics and its curricular justification. Indeed, teacher's conceptions of mathematics and its teaching 'play a significant role in shaping the teachers' characteristic patterns of instructional behavior' (Thompson, 1992: 130-131).

Research has also shown that the environment teachers create, which Malaguzzi (1998) has described as the 'third teacher', impacts significantly on children's learning. The classroom environments that teachers create, informed by the pedagogic traditions within which they operate, are culturally located to the extent that the mathematics teaching found in the classrooms of one country has characteristics that distinguish it from another (Alexander, 2000). Moreover, there is evidence to suggest that pedagogic traditions vary between the regions of a country (Andrews and Hatch, 1999, MacNab & Payne, 2003). If this is the case then it is likely that individual schools may engender a specific and unarticulated pedagogic tradition. It could be argued that teacher beliefs, as antecedents of their professional identities, impact on the environments they create for their students.

The construction and manifestation of teachers' professional identities have been extensively researched (for example: Connelly and Clandinin, 1999, Grossman and Stodolsky, 1995, Hirsch, 1993). Their research shows that identities are informed by individuals' biographies which, for teachers of mathematics, draw substantially on their relationship with the subject and their experiences of schooling (Fieman-Nemser and Buchmann 1986, Foss and Kleinsasser 1996). In this respect, Andrews' (2006) study highlights well the interrelationship between teachers' biographies - including their experiences of and attitudes towards mathematics - and the environments they create for their students. The research reported in this paper follows in similar vein. It draws on classroom teachers' 'stories' or 'narratives' (Dhunpath, 2000) in order to explicate the manner in which their professional identities inform the creation of their classroom environments.

## **Method**

In the first instance the research design negotiated with the head-teacher included interviews with children and teachers, as well as surveys and video observations throughout the whole school over the period of one week. Unfortunately, shortly after data collection began, the head-teacher fell long term ill and the project was cancelled. Consequently data collection was reduced to teacher questionnaires and, sadly no interviews or observations were permitted to take place. However, the quality of the data yielded by the questionnaires was believed to be of sufficient richness to merit analysis and reporting.

A questionnaire was developed not only to explore the teachers' espoused beliefs about and attitudes towards mathematics and its teaching, but also their relationship with the curriculum and its delivery. The questionnaire comprised a number of open questions drawn from the semi-structured questions used by Andrews (2006) in his

interviews with teachers in England and Hungary. Additionally, our analysis exploited the framework that emerged from his analysis. This comprised five curricular themes, each of which reflected His curricular themes offered categories for analysing teachers' comments, indicative of their underlying educational orientations. For example, if a teacher made comments indicating that the importance of mathematics lay in number and its application, this was recorded as a *basics-oriented* educational orientation. If comments regarding different abilities were made they would be recorded as *differentially oriented*. If they commented that the most important aspect of teaching mathematics was that children 'had life skills', this would be recorded as a *utility orientation*. Details of the themes and orientations can be seen in table 1. We felt that this to be a helpful analytical framework, as an understanding of individual teacher's orientations should not only inform further professional development opportunities but also facilitate a shift in their educational orientation (Andrews, 2006).

Thus, our starting point was to identify the range of teacher attitudes towards and beliefs about mathematics, and the type of environment they believed to be providing for their students.

### The research instrument

As indicated, the development of the questions was informed by Andrews' interview schedule. However, in order to frame our work more thoroughly, we categorised his questions into four categories. These concerned:

Teachers' Personal Experience: Attitudes and beliefs of the teacher about the subject of mathematics e.g. *What attracted you to primary teaching?* And *What was your experience of mathematics at school?*

Teachers' Personal Views: Teachers' personal views on the teaching of mathematics e.g. *What do you think your pupils think about the NNS 'style' daily numeracy lesson?* And *For you, what are the key elements of the main part of the lesson?*

Teachers' Personal Preferences: Teachers' preferences in the classroom dynamics and didactic strategies when presenting mathematics e.g. *What for you are the strengths and weaknesses of teaching the whole class together?* And *Describe a topic in mathematics you do not enjoy teaching or would not wish to teach.*

Teachers' Personal Reaction: Teachers' feelings about past and current Government expectations and recommendations e.g. introduction and implementation of the National Numeracy Strategy (NNS) and Primary National Strategy (PNS) e.g. *Has your approach to teaching changed since the introduction of the NNS? If yes how?*

Curricular theme	Educational orientation
Applicable Number	Basics – oriented
Real-world preparation	Utility – oriented



Exploration	Autonomy – oriented
Curricular given	Conformity – oriented
Student characteristics	Differentially – oriented

**Table 1: Andrews’ (2006) framework**

## Results

Seven questionnaires were returned. We had not asked the teachers for their name, age or gender, or indeed the age group they taught. However, from their responses we were able to infer particular information. Most gave responses related to the age group they taught but also their gender, e.g. *‘my brothers were considered good at maths, being a girl, I wasn’t expected to be’*. These inferences indicated that we received responses from teachers of all age groups, 4-11 years. Five teachers were identifiable as female from their responses and these, Anna, Becky, Carrie, Ellie and Gill, have been given female pseudonyms while the rest, Danni and Franci have been given androgynous pseudonyms as no inference of gender could be made.

### Personal experience of mathematics including experience as learners

Three of the seven teachers, for different reasons, claimed to enjoy mathematics. Danni described an intrinsically motivated excitement for mathematics ‘I have always enjoyed working with numbers, finding patterns and solving problems’, whereas Becky and Ellie felt it was just ‘something I could do, I just got on with it’ (Ellie). Two of the teachers (Gill and Anna) ‘did not enjoy school mathematics at all’ although both were able to distinguish between the teaching of the subject and the subject itself. The remaining teachers described an indifference to both the subject and the manner in which it was taught to them. It is interesting to note that one of these teachers ended up a primary mathematics specialist.

A common thread amongst the comments from all but one teacher concerned the ‘dullness’ and ‘uninspiring’ lessons they received in secondary school. All remember ‘plodding through the text book’ and experiencing very little ‘direct teaching’. Of all the teachers’ comments, Gill had the most negative views about the subject based on her ‘bad experience’ at primary school where she felt she had only been taught ‘tricks’ to get through tests and examinations with little in-depth understanding to build upon. She thoroughly disliked the subject and considered herself a ‘I can’t do maths’ student, which she felt was not a bad thing as it was a ‘boys’ subject, and both her brothers were good at it.

Nearly all the teachers’ comments reflect later statements about their teaching of the subject. For example Becky describes one of her teachers (her year 2/grade 1 teacher) as an inspiring influence as ‘she always played number games’. Conversely, Franci described her or his teachers of mathematics as very formal viewing them as ‘good teachers who were effective with sound discipline’. This theme of a formal and

‘traditional’ transmission-oriented (MacNab and Payne 2003, p65) education, was repeated in many of her comments regarding her own teaching.

### **Personal views on mathematics teaching.**

Despite caveats implicit in ‘it depends’, five of the seven teachers linked beliefs about curriculum mathematics to both perceptions of their students and the current curriculum regime within which they operate. Some teachers, like Becky, believed that the ‘less able’ should be taught particular topics later or much slower than recommended in the curriculum guidelines. Franci enjoys teaching the ‘more-able and talented’ as they understand her ‘clear explanations and model answers’ very quickly. All, however, recognised the pitfalls in teaching a whole-class together – something encouraged by the curriculum authority - by commenting on their concern about the ‘pace’ of lessons. They recognised how some individuals could be ‘bored’ for going too slow while others could be quite ‘stressed’ if the pace was too fast. Drawing on Andrews (2006) framework, these teachers could be described as having a *differentially-oriented* view of mathematics education.

Three of the seven teachers indicated a belief that the curricular significance of mathematics lay in the development of children’s competence and confidence in number skills, which was manifested in two ways. On the one hand, Danni and Ellie both comment on their enjoyment and importance of teaching ‘basic numeracy’ and ‘knowledge’ as a ‘useful life-skill’. On the other, Franci stressed an importance of ‘efficiency and effective arithmetical competence’. Such comments, despite their differences, suggest a worldview in which education focuses on preparation for a life beyond school; a view in which mathematics draws its curricular authority from a notion of functional arithmetic. This would be described as *basics-orientation*.

### **Personal preferences on classroom dynamics and didactic strategies**

Three teachers: Anna, Becky and Carrie, indicated a *utility-orientation* through expressions like ‘experience real-life problem-solving’ and their commitment to teaching ‘real-life’ skills so that they ‘can apply them in different situations’. Other comments were specifically related to particular topics within mathematics. For example, Ellie wrote that ‘the teaching of time, weight and capacity is most important and needs dedicated time to teach’ these ‘useful-skills’.

All seven teachers discussed different aspects of whole class teaching. For example, Franci reiterated her or his own (school) experience by preferring whole class direct teaching as (s)he then ‘does not need to repeat instructions’ to the children; reinforcing her idea of good teaching is ‘formal teaching with sound discipline’. (S)he reiterated her or his own schooling experience emphasising her or his endeavour for ‘Efficiency and clear explanations’. This could be interpreted as an indication that (s)he perceived herself to be the ‘giver’ of knowledge; a conjecture supported by her comment that, in so doing, she can provide a ‘clearer picture’ to the children than any other method. Danni also alluded to his or her ability to teach all the children all the time in a direct teaching situation as his or her preferred teaching

strategy. However, (s)he does worry about the ‘less-able’ children not being able to ‘keep-up’ with what is going on.

### **Personal reaction to the curriculum**

All seven teachers commented upon current government expectations in one form or another, and what has become known as the 3-part lesson (oral/mental starter, main part, plenary) taught over a period of between 45 and 50 minutes. Carrie wrote of the ‘oral and mental starter’ as ‘engaging children to think’, while in the main part they ‘have a go at the task set’ and in the ‘plenary’ they ‘clarify misunderstandings’. Such comments resemble well the wording of the NNS framework and indicate that she may have recently completed a course of initial teacher training in which such awarenesses would have been emphasised.

Conversely, Anna wrote that the ‘structure of the NNS sometimes lacks depth. I don’t always follow it’. In so doing she seems to reiterate an *autonomous-orientation* to education. Some of Becky’s comments allude to the same orientation but insufficiently consistently for her to be clearly defined as *autonomously oriented*. However, her responses to the questionnaire indicate that she is a recently qualified teacher which perhaps suggests she is beginning to question governmental interference and frequent educational initiatives. Ellie and Gill indicated that the NNS framework was ‘confusing, with too many different strategies to learn’ and did not like the ‘dodging from topic to topic’ which could be interpreted as alluding to having no personal freedom in planning the subject.

### **Discussion**

In respect of the teaching of mathematics both *personal views* and *personal preferences* proved to be useful themes for identifying each teacher’s perspectives on mathematics and its teaching. The evidence is suggestive of many contradictions in teachers’ espoused beliefs. For example, Carrie commented, on the one hand, on how, as a mathematics specialist, she enjoys teaching the ‘real’ nature of mathematics and helping children to ‘see links and patterns, using it to solve problems’. On the other hand, she later declared that she had no preferences for the topics she is obliged to teach. One would have thought that a mathematics specialist (by definition interested in mathematics) would have strong views about topics they teach.

Whilst avoiding making too strong assertions, an interesting connection was made between the two teachers (Anna and Gill) who experienced ‘poor teaching’ of mathematics in their own schooling. They were both conscious (as teachers) of the needs of individuals who struggle with mathematical concepts, and commented on attempts to encourage confidence, achievement and enjoyment in their mathematics lessons. Danni, who enjoyed mathematics as a learner, wrote of a desire to encourage student enjoyment of mathematics, but seemed only to see this as deriving from the manner in which he or she presented the subject and little to do with the environment, being the giver and motivator of all mathematical knowledge. Such rhetoric alludes to

a conditionally constructed *autonomous orientation* while alluding to a teacher whose practice had remained largely unchanged throughout his or her career.

There are clearly many issues raised by the questionnaires about the teacher's views and attitudes about the subject of mathematics, but also the way in which it should be taught. The figures of table 2 highlight a skew in the educational orientations of project teachers.

	Basics	Utility	Autonomy	Conformity	Differential
Anna	0	4	3	2	4
Becky	0	5	1	1	12
Carrie	4	4	1	5	3
Danni	7	4	3	1	3
Ellie	2	1	0	5	5
Franci	1	2	0	6	1
Gill	1	2	1	1	7
Totals	15	22	9	21	35

**Table 2: frequencies of educational orientations inferred from responses**

It can be seen from the figures of table 2 that all seven teachers, in differing degrees, exhibited *conformity*, *utility* and *differential* orientations. These seem to reflect preferences towards a more personalised, real-life context focussing on individualised preparation for the world within a tightly controlled learning experience. This contrasts with the *utility*, *conformity* and *basics-orientation* prominence found in English secondary teachers of mathematics (Andrews, 2006). More importantly perhaps, is the lack of *autonomy orientation* and its commensurate emphases on the development of children's logical thinking and arithmetical competence. Such findings resonate with those from a similar study carried out in Scottish primary schools (MacNab and Payne, 2003). Interestingly, it appears that the two teachers exhibiting a more *autonomous orientation* are upper primary teachers providing further data for the headteacher to consider.

Consequently, these findings offer a possible explanation for the disparity in the project school's mathematical attainment. The questionnaires indicated that six of the seven teachers (Gill held different views) present a confident and optimistic perspective on their ability to deliver, in their view, an appropriate mathematical experience to their children, even though they clearly do not agree with many aspects of the curricular guidance. Of these, two viewed themselves as the centre of all knowledge and describing good practice as traditional transmissive teaching. However, such perspectives are unlikely to afford many exploratory learning opportunities for logical thinking. Others discussed particular topics which they preferred to teach, for example, Ellie wrote about teaching the 24 hour clock, while Anna wrote about weight, time and capacity, all of which are topics unlikely to

provide logical challenges or offer learners an indication as to the deductive nature of mathematical thinking (Ernest, 1995). Indeed, very few comments related to the ‘elegance’ of mathematical structure and relationships.

Another inference to be drawn from our data is that inexperienced teachers like Becky and Carrie felt confident in the prescribed curriculum, unaware of the contradiction implied by their comments concerning child-centred teaching, reiterating the findings of MacNab and Payne (2003). The experienced teachers focussed attention on didactic strategies at the expense of any engagement with mathematics and logical thinking, indicating a concern more with ‘how to teach’ than ‘what to teach’. MacNab and Payne (2003) also highlighted how primary teachers lacked the ability to articulate and discuss issues in mathematics education. They too espoused a child-centred pedagogy but possessed little feel for mathematical structure, and were confident as long as they stayed within the bounds of mathematics as a real-life activity.

### Conclusions

This paper has not set out to compare this particular set of English primary teachers with primary teachers elsewhere but to use comparative studies as a framing device for improving practice in a particular primary school. The argument is that if each country has a culturally defined practice (Clarke, 2003; Andrews, 2006; Stigler and Perry, 1990), and if each region of a country has a culturally defined practice (Andrews and Hatch, 1999) then it would not be surprising to find that each school has a culture of its own and this seems to be the case here.

The data support a conclusion that the teachers of this school are not only conservative in their practice but also compliant with the constraints of the current curriculum framework. This suggests that most learners are given few opportunities to engage with anything beyond an *instrumental* (Skemp, 1977) experience of mathematics. While the beliefs, attitudes and espoused practice of our project teachers cannot be wholly responsible for the lack of pupil achievement, they, along with curricular structures and the social and cultural organisation of the school, are likely to be contributory to it. Such conservative and confirmative practices allude to a school culture in which risk aversion and a consequent failure to challenge children’s thinking dominate.

This project suggests that teachers with an *autonomous orientation* are more likely to attend to their learners’ mathematical thinking and broadening understanding. In order to shift the perspectives of the teachers of this school and influence their practice much work will have to be done. The view is that little change can be brought about until colleagues are aware of and accept the limitations of their current beliefs and practices. In order to do this recommendations will be made to the head-teacher that a series of workshops, based on collaborative problem solving, be developed in which teachers are exposed to mathematical tasks and problems that

exemplify the nature of mathematics, facilitate and extend mathematical thinking but which have an explicit and obvious didactic transference to their classrooms.

## References

- Alexander, R.: 2000, *Pedagogy and Culture: International comparisons in primary education*, Blackwell, Oxford.
- Andrews, P.: 2006, 'The curricular importance of mathematics: a comparison of English and Hungarian teachers' espoused beliefs', *Journal of Curriculum Studies*. (In press).
- Andrews, P. and Hatch, G.: 1999, 'A new look at secondary teachers' conceptions of mathematics and its teaching', *British Educational Research Journal* 25(3), 203–223.
- Beaton, A.E., Mullis, I.V.S., Martin, M.O., Gonzalez, E.J., Kelly, D.L. and Smith, T.A.: 1996, *Mathematics in the Middle School Years: IEA's Third International Mathematics and Science Study (TIMSS)*, Boston College, Boston MA.
- Clarke, D.: 2003, 'International Comparative Studies in Mathematics Education', in A. Bishop, M. Clements, C. Keitel, J. Kilpatrick, and F. Leung (eds.), *Second International Handbook of Mathematics Education*, Kluwer, Dordrecht).
- Connelly, M. and Clandinin, J.: 1999, 'Composing, sustaining, and changing stories to live by', in M. Connelly and J. Clandinin (eds.), *Shaping a professional identity*, Teachers College Press, New York.
- Dhunpath R.: 2000, 'Life history methodology: 'narradigm' regained', *Qualitative Studies in Education* 13 (5), 543-551.
- Ernest, P.: 1995, 'Values, gender and images of mathematics: a philosophical perspective', *International Journal of Mathematical Education in Science and Technology* 26(3), 449–462.
- Feiman-Nemser, S. and Buchmann, M.: 1986, 'The first year of teacher preparation: transition to pedagogical thinking', *Journal of Curriculum Studies* 18, 239–256.
- Foss, D. and Kleinsasser, R.C.: 1996, 'Preservice elementary teachers' views of pedagogical and mathematical content knowledge', *Teaching and Teacher Education* 12(4), 429–442.
- Grossman, P. and Stodolsky, S.: 1995, 'Content as context: the role of school subject in secondary school teaching', *Educational Researcher*, 24 (8), 5-11, 23.
- Hirsch, G.: 1993, 'Biography and teacher identity: a typological analysis of life-history data', *Qualitative Studies in Education*, 6 (1), 67-83.
- MacNab D.S. and Payne, F.: 2003, 'Beliefs, Attitudes and Practices in Mathematics Teaching: perceptions of Scottish primary school student teachers', *Journal of Education for Teaching*. 29 (1).

Malaguzzi, L.: 1998, History, Ideas and Basic Philosophy, in Edwards, C., Gandini, L. and Forman, G. (eds.), *The Hundred Languages of Children (2<sup>nd</sup> edition)*, Ablex, Greenwich, CT.

Mullis, I., Martin, M., Gonzalez, E., Gregory, K., Garden, R., O'Connor, K., Chrostowski, S. and Smith, T.: 2000, *TIMSS 1999 International Mathematics Report*, Boston College, Boston MA.

Organisation for Economic Cooperation and Development (OECD): 2001 *Knowledge and Skills for Life: First results from the OECD programme for international student assessment*, OECD, Paris.

Organisation for Economic Cooperation and Development (OECD): 2004, *Learning for tomorrow's world: First results PISA 2003*, OECD, Paris.

Skemp, R.R.: 1976, 'Relational Understanding and Instrumental Understanding' *Mathematics Teaching*, 77, 20-26.

Stigler, J.W. and Perry, M.: 1990, 'Mathematics learning in Japanese, Chinese and American classrooms', in J.W. Stigler, R.A. Shweder and G. Herdt (eds.), *Cultural Psychology: Essays on Comparative Human Development*, Cambridge University Press, Cambridge.

Thompson, A.G.: 1992, 'Teachers' beliefs and conceptions: a synthesis of the research', in Grouws, A.D. (ed.), *Handbook of Research on Mathematics Teaching and Learning*, Macmillan, New York.

Travers, K.J., Garden, R.A. and Rosier, M.: 1989, 'Introduction to the study', in D. Robitaille and R. Garden (eds.), *The IEA study of mathematics II: contexts and outcomes of school mathematics*, Pergamon, Oxford.

## **THE TEACHING MODES: A CONCEPTUAL FRAMEWORK FOR TEACHER EDUCATION**

Rosa Antónia Tomás Ferreira

Science Faculty of the University of Porto, PORTUGAL

*In this paper, I describe the conceptual framework that was constructed and used to conduct a teacher development experiment with a group of four Portuguese secondary mathematics student teachers over the course of their year-long student teaching practicum. This framework was built based on existing research and on theoretical developments in the field of mathematics education. Alongside guiding and informing the methodological procedures of a larger study, the conceptual framework itself was investigated for its adequacy to analyze and interpret classroom teaching with the aim of improving classroom instruction.*

The oral communication between teacher and students plays an important role in students' learning, and teachers' questioning, listening, and responding approaches may be seen as laying at the core of classroom communication. These three facets of teachers' practices have been suggested to characterize their pedagogical approaches and to reflect their beliefs about mathematics and its teaching and learning. Furthermore, analyses of how teachers question, listen, and respond to their students have been shown to provide an avenue for helping teachers become aware of their own beliefs and practices, and improve their teaching (e.g., Coles, 2001; Nicol, 1999; Tomás Ferreira & Presmeg, 2004).

In this paper, I elaborate on the notion of teachers' teaching modes (that is, their interrelated questioning, listening, and responding approaches in the classroom), and I describe the conceptual framework (CF) that was constructed to conduct a research study<sup>1</sup> involving a group of four Portuguese secondary mathematics student teachers (Tomás Ferreira, 2005). Based on existing research and on theoretical developments in the field of mathematics education, I built a CF that was used to conduct the study, whose major goal was to trace and understand how the teaching modes of the participants evolved over the course of their year-long student teaching practicum. Following a teacher development experiment research design (Simon, 2000), I played the role of researcher/teacher-educator. Data were collected using filed notes, audiotaped lessons, interviews, and various documents. Ongoing and retrospective analyses were based on the CF. Yet, the CF itself was investigated for its adequacy for analyzing and interpreting classroom teaching and for informing the data collection and analysis procedures. In the following sections, I present and discuss this CF, leaving the results and implications of the major study to a further paper.

---

<sup>1</sup> This work was partially funded by the Grant PRAXIS XXI/BD/19656/99 from *Fundação para a Ciência e a Tecnologia*, and from *Centro de Matemática da Universidade do Porto*, Portugal.



## THE CONCEPTUAL FRAMEWORK

As shown in Table 1, the framework comprises several strands, each of them drawn from other frameworks that have been used in mathematics education research. Next, I present a brief description of each one of the framework's strands.

Table 1. The Teaching Modes

TEACHING MODES	Teachers' key beliefs	Dominant patterns of classroom interaction	Levels of reflective thinking
		IRE	
EVALUATIVE	Instrumentalist	Funnel Elicitation	Technical rationality
INTERPRETIVE	Platonist	Direct mathematization	Practical action
GENERATIVE	Problem-solving	Focusing Discussion	Critical

## TEACHERS' REFLECTIVE THINKING

The notion of reflection has not found a consensus amongst researchers or teacher educators, not even amongst theoreticians. I considered teachers' reflective thinking as being "teachers' intentional engagement in thinking about their classroom practices with two main goals: (a) becoming aware of their actions in the classroom and of their key beliefs about mathematics ... against the perspectives on mathematics teaching and learning envisioned by current school mathematics reform movements; and (b) using those insights to improve their teaching ... and, ultimately, their students' learning" (Tomás Ferreira, 2005, p. 34). Several authors and researchers have offered various frameworks for better understanding or improving teachers' reflective thinking. I chose Van Manen's (1977) model for its comprehensiveness and simplicity of use given the purposes of my study (Tomás Ferreira, 2005). Van Manen (1977) suggested a three-level model for teachers' reflective thinking which I used as a tool to analyze the quality of teachers' predominant reflective thinking. Briefly, at the technical rationality level, teachers focus on the effective and efficient application of educational knowledge – which is never questioned – to attain a given goal. In general, only one way of teaching is acknowledged. At the practical action level, teachers focus on analyzing the nature, quality, and effects of their educational actions, assessing the appropriateness of various teaching strategies and looking for guidance to their classroom practices. In my view, at the technical rationality level, teachers predominantly reflect *on* action, rather than *in* action – in Schön's (1983) terms. Finally, at the critical level, the teaching and its context are problematized. Teachers' high degree of open-

mindedness leads them to look for reasons – including goals – for their actions in the classroom, as well as for educational consequences of those actions. In my opinion, and again in Schön’s (1983) terms, critical reflective teachers tend to reflect both *in* and *on* action.

## TEACHERS’ BELIEFS

There is not an agreement about the definition of the construct of teachers’ beliefs amongst the mathematics education research community. In any case, teachers’ beliefs about mathematics shape their beliefs about mathematics teaching and learning. In turn, these beliefs are reflected in their classroom practices (e.g., Thompson, 1992). Though many models for characterizing teachers’ beliefs about mathematics and its teaching and learning have been proposed, I chose Ernest’s (1989) for the same reasons I chose van Manen’s (1977) for teachers’ reflective thinking and also for the parallel I found between the levels of each model. Ernest (1989) introduced the notion of mathematics teachers’ key beliefs, which concern their views of mathematics as a whole, their orientations towards mathematics learning, and their models of mathematics teaching. He suggested a model for teachers’ key beliefs comprised of three levels which I summarize in Table 2. By teachers’ classroom practices I mean their actions in the classroom which are not seen in isolation but rather contextualized within teachers’ key beliefs about mathematics and its teaching and learning.

Table 2. Ernest’s Model for Teachers’ Key Beliefs about Mathematics

KEY BELIEFS	Math as a whole	Learning math	Teaching math
INSTRUMENTALIST Teacher as instructor	Accumulated set of facts, rules, and skills	Acquiescent mastery of skills and procedures	Textbook-driven (clear explanations; classroom control)
PLATONIST Teacher as explainer	Unified body of knowledge, discovered, not created	Passive receiving of knowledge	Textbook-driven with enriching tasks (instruction built on prior knowledge)
PROBLEM-SOLVING Teacher as facilitator of student learning	Dynamic, continually expanding field of human creation	Social and individual process of active construction of meaning	Inquiry-driven: focus on the hows and whys of concepts and procedures

## PATTERNS OF CLASSROOM INTERACTION

The patterns of classroom interaction are usually established by all classroom members, and they emerge “from the permanent interaction between teacher and

students, as well as among students themselves” (Bauersfeld, 1992, p. 21). Several patterns of classroom interaction have been identified by research but I focused on six of them: (a) the IRE pattern, (b) the funnel pattern, (c) the elicitation pattern, (d) the direct mathematization pattern, (e) the focusing pattern, and (f) the discussion pattern. The IRE pattern is the most commonly observed in classrooms and follows a basic structure: the teacher initiates the interaction by posing a question, the student responds hoping to give the answer the teacher expects to hear, and the teacher evaluates the student’s contribution against the preconceived response she had in mind (e.g., Cobb, Wood, Yackel, & McNeal, 1992; Voigt, 1985). The funnel pattern also begins with a question posed by the teacher, who, realizing the students’ difficulties in providing an adequate answer, begins a spiral sequence of increasingly cognitively simpler questions that break the content of the initial question into less complex pieces. Thus, the students’ thinking is successively funnelled towards the desired answer which, more often than not, is the product of the teacher’s cognitive work, not the students’ (Voigt, 1985; Wood, 1998). According to Voigt, the elicitation pattern follows three typical phases. Firstly, the teacher presents a task that students cannot solve immediately. They suggest a few solutions or resolutions which the teacher quickly evaluates. Secondly, the teacher guides the students towards a certain method or solution – especially if students’ suggestions are very divergent – adopting an instructional approach very similar to the funnel pattern. The last phase is characterized by the teacher’s and students’ reflection and evaluation of whatever was done. The direct mathematization pattern also begins with students’ work on a task that is not immediately solved. The task is open enough to allow for several interpretations which, in turn, give way to different mathematizations of the situation at hand. However, the teacher reduces the possibilities by focusing on specific conventions for interpreting the task, forcing the students to follow her own mathematization (Voigt, 1995), and contributing to students’ learning of “how to tackle particular or stereotypical problems using stereotypical methods or algorithms, without having the understanding of the mathematics underneath” (Tomás Ferreira, 2005, p. 60). The focusing pattern also entails a certain guidance of student thinking, through questioning. However, the students are stimulated to express their thinking. The teacher accepts and values various solutions to the same task, highlighting a specific one because it is interesting or problematic to the students – from the teacher’s point of view – not because it is the solution that the teacher wants to impose, as is the case of the direct mathematization pattern. Under the discussion pattern, the students work, in small groups, on a problem posed by the teacher. A student is then asked to report on the work of his or her group, explaining the solution all group members have achieved. The teacher intervenes in the explanations by posing further questions, providing helping hints, or making small judgements, contributing to the emergence of a joint explanation that is understood and validated by the whole class. Afterwards, other students are invited to report on their own group’s alternative solutions, and the cycle of discussions and negotiations of meanings begins again (e.g., Voigt, 1995; Wood, 1998). The first three patterns are

typical of traditional classrooms whereas the two latter ones dominate inquiry classrooms. The direct mathematization pattern lies somewhere in between those two types of classroom cultures though leaning more towards traditional classrooms. Acknowledging the differences that exist amongst all these patterns, I grouped the IRE, funnel, elicitation, and direct mathematization patterns into what I called traditional patterns; the focusing and discussion patterns were called inquiry patterns. This grouping allowed the use of patterns of classroom interaction as means for comparison of typical traditional and inquiry classrooms.

## **TEACHERS' QUESTIONING, LISTENING, AND RESPONDING**

Though teachers' questioning, listening, and responding approaches are three aspects of classroom communication that are too interconnected to be treated separately (e.g., Coles, 2001; Davis, 1997; Nicol, 1999), next, I provide a brief snapshot of those three dimensions, addressing them in a more or less separate way in order to illustrate the singular contributions each one of them offers to the classroom discourse.

### **Questioning**

A teacher can ask many types of questions of her students and several classifications of questions, with more or less common denominations and characteristics, have been put forward by numerous researchers (e.g. Moyer & Milewicz, 2002). Yet, the essential differences in the questions posed to the students must be seen taking into account the context in which the questions are posed and the nature of the interaction that follows (Dillon, 1990). For this study, I used Ainley's (1988) framework, composed of four categories of questions according to teachers' purposes when posing questions to students. By asking *pseudo questions*, teachers intend to establish an acceptable behaviour or a social contract with their students. These questions merely require students' agreement with the teacher, but they are also used to accentuate the power imbalance that exists between the teacher and the students or to retain the classroom control. Teachers' goal with *testing questions* is to find out if students respond correctly. Teachers know the answers to testing questions and the students are typically aware of it. Furthermore, students tend to perceive all questions as testing questions, even if they fall into a different category. Testing questions may also be used to check for teaching effectiveness. As the name itself suggests, the goal of *genuine questions* is to seek information; thus, teachers do not know the answers to this type of questions. Finally, *provoking questions* are aimed at provoking students' thinking by making new connections or clarifying existing ones, by exploring new areas of mathematical knowledge, etc. Unlike testing questions, teachers do not necessarily know the answers to provoking questions and students may or may not be aware of this fact (Ainley, 1988). Provoking questions are not a panacea of adequate questioning. Teachers should ask many questions of various types to stimulate different levels of student thinking, and to encourage the participation of all students in classroom events. Yet, research has shown that, typically, teachers overuse testing and pseudo-questions, do not encourage student-generated questions, and elicit rote and short responses (e.g., Dillon, 1990; Moyer & Milewicz, 2002).

## Listening

Traditionally, teachers' usual purpose for listening to their students is "to diagnose and to remediate difficulties" (Davis, 1994, p. 279) against a pre-conceived set of standards. Yet, teachers' listening goes much further than paying attention to words as it involves teachers in an empathetic and respectful grasping of the overtones and implications of each student's contributions to the classroom discourse (e.g., Nicol, 1999). Thus, teachers should actually listen to students' contributions to classroom discourse, and use such a crucial tool for taking informed instructional decisions. From a more reform-oriented standpoint, teachers' listening requires the devotion of a considerable amount of time to imagining how students think and how they would approach a specific problem, and a deep and thorough understanding of mathematics. Moreover, listening is the actual counterpart of questioning as opposed to answering. Davis (1997) constructed a framework comprising three modes for teachers' listening which are different from one another but complementary to each other: *evaluative*, *interpretive*, and *hermeneutic*. In brief, *evaluative* listeners look for particular responses, merely evaluating students' knowledge against a pre-conceived set of *right answers*. Teachers who are evaluative listeners strive to avoid "any kind of ambiguity, and keep[] strict track of their lesson plans" (Tomás Ferreira, 2005, p. 82). Teachers dominate the classroom discourse and students' input to that discourse is largely ignored. *Interpretive* listeners use active listening to access and interpret students' thinking, although from their own perspectives (Davis, 1997). Teachers listening in an interpretive mode encourage students' explanations and justifications but they still look for specific responses. Students' contributions to the discourse still do not impact the lesson unfolding in a significant way as teachers continue relying significantly on direct and structured instruction and allocating the locus of authority to themselves. *Hermeneutic* listeners are active participants in the exploration and negotiation of meanings with their students, and use what they hear from the class to construct knowledge with the students. Thus, having no pre-specified responses in mind, hermeneutic listening is aimed at accessing and assessing students' thinking in order to inform instruction. Teachers' hermeneutic listening – which is perceived as complementary to the other two listening modes – stimulates students to engage in mathematically rich discussions, and teaching itself is seen as "a matter of flexible responses, within a learning environment in constant change" (Tomás Ferreira, 2005, p. 84). Unlike for the evaluative and the interpretive listening modes (the most common listening modes in current classrooms), the hermeneutic mode implies an even division of the locus of authority amongst all classroom members.

## Responding

Teachers' responding approaches are based on the understanding derived from their listening to students' ideas or comments (Nicol, 1999). Teachers' responses can help students develop their mathematical competences and become more and more autonomous in their own learning. For example, teachers may respond to students by probing them, redirecting comments to the class, posing follow-up questions, or

providing feedback. Yet, despite the lack of research about this particular component of classroom communication, there is evidence that teachers tend to respond to students by judging their utterances as right or wrong, discouraging them from further intervening in the classroom discourse (e.g., Moyer & Milewicz, 2002). Responding to students is also related to the goals of the questions teachers ask of them (e.g., Nicol, 1999). Thus, “a testing question ... may merely require judgment about its correctness ... [while] genuine and provoking questions ... necessarily demand a different response from the teacher, otherwise their instructional purpose and usefulness will be lost” (Tomás Ferreira, 2005, p. 89).

Research on teachers’ questioning, listening, and responding approaches has not been extensive, especially at the pre-service level. Student teachers have been found to typically begin their teaching experiences by posing many testing questions and hardly asking any provoking ones. They tend to listen to students in an evaluative mode and to respond to them by judging the correctness of their answers. Moreover, these practices usually collide with what they allegedly believe in terms of classroom teaching. Yet, with adequate support and feedback, student teachers can gradually become aware of the pros and cons of their questioning, listening, and responding. In turn, this awareness may stimulate them to pose questions that help students in developing their mathematical competences, to listen to students in an increasingly hermeneutic mode, and to respond to them in manners that help in strengthening their mathematical knowledge (e.g., Nicol, 1999; Tomás Ferreira, 2005).

## THE TEACHING MODES

Due to the interrelationship amongst teachers’ questioning, listening, and responding approaches in the classroom, the term *teaching modes* was introduced (Tomás Ferreira & Presmeg, 2004), by extending Davis’s (1997) model for teachers’ listening modes to include Ainley’s (1988) categories of questions and teachers’ different ways of responding to students. The teaching modes were considered not in isolation but sharing some qualitative characteristics. Figures 1 through 3 illustrate the anticipated relationships amongst a teacher’s usual teaching mode and the other three strands of the CF (the thicker the linking lines in the figures, the stronger the relationships amongst the constructs were likely to be). Yet, *exact* correspondences between a teacher’s teaching mode and her key beliefs, levels of reflective thinking, and predominant patterns of classroom interaction were not expected beforehand. In brief, overusing pseudo and testing questions, listening to students in an evaluative mode, responding to students to evaluate their answers, and teaching very closely following the textbook and lesson plans are characteristics of *evaluative teaching*. These teachers tend to direct student thinking towards desired responses, thus valuing products over processes. They see communication as being a matter of speaking but students’ contributions to the classroom discourse are largely ignored, privileging traditional patterns of classroom interaction. Teachers teaching in an evaluative mode strive to avoid any ambiguity, to deliver clear explanations, and to allocate the classroom locus of authority to themselves. Teachers teaching in evaluative mode

tend to hold instrumentalist beliefs about mathematics and its teaching and learning (Ernest, 1989), and to be very simplistic in their reflective thinking, focusing on superficial aspects of their practice, which they never question, that is, reflecting at van Manen's (1977) technical rationality level.

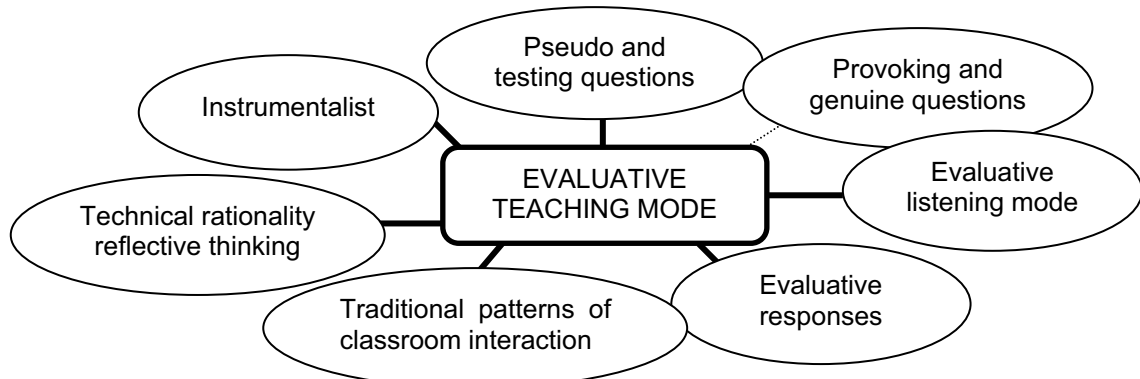

Figure 1. Evaluative teaching mode.

*Interpretive teaching* is focused on the establishment of a common language inside the classroom, valuing the social aspect of learning. Teachers teaching in an interpretive mode ask fewer testing questions and more genuine and provoking questions than if they were teaching in an evaluative mode. The interpretive listening mode is characteristic of an interpretive teaching mode; thus, teachers increase opportunities for classroom interaction and discussion. However, responding to students still tends to be evaluative in nature, and typical instructional approaches are mainly textbook-driven, though enriched with problems and other tasks. Within a classroom environment based on interpretive teaching, students' contributions to the discourse still do not have a significant impact on lesson unfolding, since despite some room for inquiry patterns of interaction, the traditional ones are clearly predominant. The locus of authority is mainly allocated to the teacher.

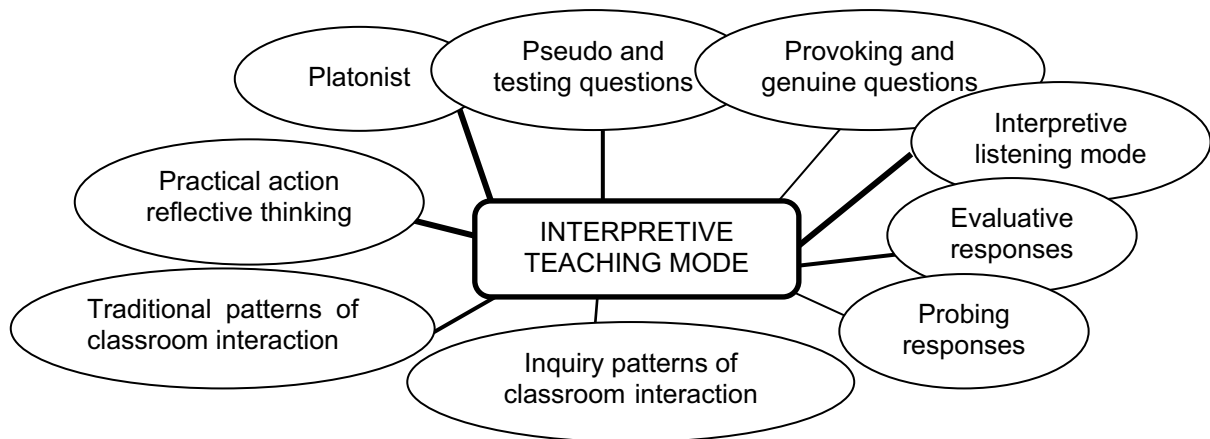

Figure 2. Interpretive teaching mode.

Regarding the *generative teaching* mode, communication is about participating, interpreting, and negotiating meanings, and it involves all classroom members alike. Genuine and provoking questions dominate the typical discourse of these teachers, although there is room for pseudo and testing questions as well. The hermeneutic

listening mode characterizes generative teaching, and teachers respond to students by stimulating further discussion (by probing, redirecting questions or comments, etc.). Instruction is inquiry-driven. Generative teaching necessarily implies teachers' questioning of their own practices and beliefs, and revising of their own mathematical knowledge while exploring and constructing mathematical ideas with their students. The locus of authority is evenly divided amongst teacher and students.

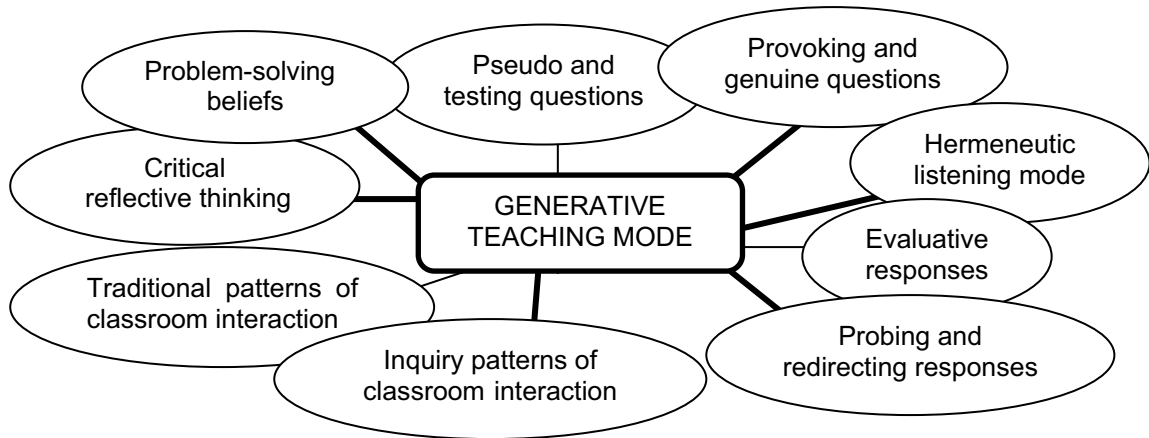

Figure 3. Generative teaching mode.

The CF here described served as a fundamental tool for promoting and studying gradual changing practices, namely by guiding my actions as a teacher educator and my data collection and analysis procedures as a researcher. Yet, some of the participants did not perceive the CF as a tool for professional development; those who did see its relevance were the ones struggling to teach in an increasing generative teaching mode. Moreover, the study also problematized the CF as there were some inconsistencies amongst its four strands. Whereas the anticipated relationships between teachers' teaching modes and dominant patterns of classroom interaction, and between teachers' key beliefs and levels of reflective thinking were somewhat *confirmed*, there were inconsistencies between those two groups of teaching aspects. A new category of questions seemed to be necessary: *rhetorical questions*, used to structure the teacher's natural speech or as a form of defense against irritability or lack of content knowledge (Tomás Ferreira, 2005). Despite much need for further research and wider use of the CF, it proved to be useful as a reflective research tool to analyze classroom teaching and improve students' learning, whether in teacher education or in professional development programs.

## REFERENCES

- Ainley, J.: 1988, 'Perceptions of teachers' questioning styles', in A. Borbás (ed.), *Proceedings of the 12th Annual Meeting of the International Group for the Psychology of Mathematics Education*, Veszprém, Hungary, pp. 92 – 99.
- Bauersfeld, H.: 1992, 'Integrating theories for mathematics education', *For the Learning of Mathematics*, 12 (2), 19 – 28.
- Cobb, P., Wood, T., Yackel, E., & McNeal, E.: 1992, 'Characteristics of classroom mathematics traditions: An interactional analysis', *American Educational Research Journal*, 29 (3), 573 – 604.



- Coles, A.: 2001, 'Listening: A case study of teacher change', in M. van den Heuvel-Panhuizen (ed.), *Proceedings of the 25th Annual Meeting of the International Group for the Psychology of Mathematics Education*, Utrecht, The Netherlands, vol.2, pp. 281 – 288.
- Davis, B.: 1994, 'Mathematics teaching: Moving from telling to listening', *Journal of Curriculum and Supervision*, 9 (3), 267 – 283.
- Davis, B.: 1997, 'Listening for differences: An evolving conception of mathematics teaching', *Journal for Research in Mathematics Education*, 28 (3), 355 – 376.
- Dillon, J. T.: 1990, *The practice of questioning*, Routledge, London, UK.
- Ernest, P.: 1989, 'The impact of beliefs on the teaching of mathematics', in P. Ernest (ed.), *Mathematics teaching: The state of the art*, The Falmer Press, NY, pp. 249 – 254.
- Moyer, P. S., & Milewicz, E.: 2002, 'Learning to question: Categories of questioning used by preservice teachers during diagnostic mathematics interviews', *Journal of Mathematics Teacher Education*, 5 (4), 293 – 315.
- Nicol, C.: 1999, 'Learning to teach mathematics: Questioning, listening, and responding', *Educational Studies in Mathematics*, 37 (1), 45 – 66.
- Schön, D.: 1983, 'The reflective practitioner: How professionals think in action', Basic Books, Inc. Publishers, New York.
- Simon, M.: 2000, 'Research on the development of mathematics teachers: The teacher development experiment', in A. E. Kelly & R. A. Lesh (eds.), *Handbook of research design in mathematics and science education*, Lawrence Erlbaum Associates, Mahwah, NJ, pp. 335 – 359.
- Thompson, A.: 1992, 'Teachers' beliefs and conceptions: A synthesis of the Research', in D. A. Grouws, (ed.), *Handbook of research in mathematics teaching and learning*, Macmillan, NY, pp. 127 – 146.
- Tomás Ferreira, R. A., & Presmeg, N.: 2004, July, 'Classroom questioning, listening, and responding: The teaching modes', Paper presented at the 10th International Congress of Mathematics Education, Copenhagen, Denmark.
- Tomás Ferreira, R. A.: 2005, *Portuguese student teachers' evolving teaching modes: A modified teacher development experiment*. Unpublished Doctoral Dissertation. Illinois State University, Normal, IL, USA.
- Van Manen, M.: 1977, 'Linking ways of knowing with ways of being practical', *Curriculum Inquiry*, 6 (3), 205 – 228.
- Voigt, J.: 1985, 'Patterns and routines in classroom interaction', *Recherches en Didactique des Mathématiques*, 6(1), 69 – 118.
- Voigt, J.: 1995, 'Thematic patterns of interaction and sociomathematical norms', in H. Bauersfeld & P. Cobb (eds.), *The emergence of mathematical meaning: Interaction in classroom cultures*, Lawrence Erlbaum Associates, Hillsdale, NJ, pp. 163 – 201.
- Wood, T.: 1998, 'Alternative patterns of communication in mathematics classes: Funneling or focusing?', in H. Steinbring, M. G. Bartolini Bussi, & A. Sierpiska (eds.), *Language and communication in the mathematics classroom*, National Council of Teachers of Mathematics, Reston, VA, USA, pp. 167 – 178.

# THE MATHEMATICS CONTENT KNOWLEDGE OF BEGINNING TEACHERS: THE CASE OF AMY

Fay Turner

University of Cambridge

*This paper takes forward work carried out by colleagues on using the knowledge quartet framework (KQ) as a tool for the identification of content knowledge as revealed through the practice of trainee teachers. I report on some work in which the framework has been used with a group of beginning elementary school teachers. In this study the teachers participate as co-learners (Wagner, 1997) in developing their teaching through reflection using the KQ. The findings reported here are from the first two years of a four year study. These findings concern the case of Amy in relation to just one dimension of the KQ: foundation knowledge.*

## INTRODUCTION

At the CERME meeting in Bellaria, Italy, Rowland, Huckstep and Thwaites (2003) presented a paper in which they discussed research which suggested that subject matter knowledge (SMK) and pedagogical content knowledge (PCK) could be seen to underpin the pedagogical decisions made by prospective teachers. At the following CERME meeting in Spain, Tim Rowland presented a paper (Rowland, Huckstep and Thwaites, 2005a), which explained how this work had been developed to produce a framework for the identification and discussion of teachers' mathematics content knowledge as evidenced in their teaching. The researchers called this framework the *knowledge quartet* (KQ). In the final comments and caveats of this paper, Rowland *et al.* (2005a) suggested that the *knowledge quartet* offers a useful framework for discussion of mathematics teaching with trainees and their mentors. They further proposed that trainees and mentors should be familiarised with this framework in order to provide shared understandings for dialogue and reflection on mathematics teaching. In this paper I describe how such familiarity has been developed working with teachers over a two year period. The framework has been used as a tool for discussion and reflection of mathematics teaching with a group of teachers. In this paper I focus on the development of one teacher in relation to one of the four dimensions of the *knowledge quartet* framework, the *foundation* dimension.

The *knowledge quartet* framework is made up of four dimensions termed *foundation*, *transformation*, *connection* and *contingency*. The *foundation* dimension includes the theoretical knowledge of both SMK and PCK as well as beliefs about mathematics and mathematics teaching. This dimension is seen as underpinning the other three. *Transformation* encompasses the ways in which the teacher's own knowledge is transformed to make it accessible to the learner. *Connection*, includes issues of sequencing and connectivity as well as complexity and conceptual appropriateness. Finally *contingency* covers the way in which teachers respond to unplanned instances in a lesson. This could be described as 'thinking on your feet'. Further details of the

quartet and its development can be found in Rowland, Huckstep and Thwaites (2005b). Within each dimension there are a number of different aspects or codes which may be identified from observations of teaching. Codes encompassed within the *foundation* dimension, on which I focus in this paper, are awareness of purpose, identifying errors, overt subject knowledge, theoretical underpinning of pedagogy, use of terminology, use of textbook and concentration on procedures.

## **PURPOSE OF THE RESEARCH**

Research in the United States and in England has suggested that elementary school teachers do not have the content knowledge necessary for effective teaching (Post et al, 1991; Brown, Cooney and Jones, 1990; Deborah Ball, 1990; OFSTED, 2000). The work of Liping Ma (1999), in a comparative study of Chinese and American teachers, has pointed to the difficulties inherent in improving children's understanding of mathematics when the understanding of their teachers is insecure. Improving teachers' understanding of mathematics would seem to be a necessary condition for breaking the cycle of inadequacies in mathematics teaching and learning. This study set out to investigate the way in which beginning teachers' understanding of mathematics content knowledge needed for teaching might be developed through reflection on their teaching (Schön, 1983) using the knowledge quartet framework. I chose to work with beginning teachers in order that their reflections might draw on recent experiences of learning about mathematics and mathematics teaching during their training year.

## **METHOD**

The participants in the study were students on a one year post graduate teacher education course at the University of Cambridge. Three months into the course a lecture explaining the research that led to the development of the *knowledge quartet* was given to all trainees in the 2004-5 cohorts. Following the lecture, an outline of the intended research was given and trainees were invited to take part. Of the 214 students there were 36 volunteers and Amy was selected as one of 12 initial participants. She had the minimum requirement in terms of mathematics qualifications for elementary school teaching and expressed a lack of confidence in her own mathematical ability. Familiarity with the *knowledge quartet* framework was enhanced by giving participants a document outlining each of the four dimensions, and offering a number of questions to ask about planning and teaching within each dimension. Participants were asked to familiarise themselves with this.

One mathematics lesson of each participant trainee teacher was observed and video-taped during their final teaching practice placement in schools. This was analysed in terms of the four dimensions of the KQ, and relevant issues were identified for discussion with the trainee. Within the same day, the trainee teacher watched the video-tape and was invited to comment on the lesson. Participants were asked questions relating to issues identified in the analysis of the lesson and encouraged to discuss these issues. This use of stimulated recall, along with focused prompts was

employed to facilitate reflection on issues of mathematical content. These discussions were audio-taped for later transcription and analysis. At the end of their training the participants all met with me to discuss their feelings about the study so far and the way in which they would like it to continue.

Nine of the 12 participants who had obtained posts teaching children aged between 4 and 11 years took part in the second year of the study. During this year the participants were observed and video-taped on two occasions. Issues of content knowledge were identified using the KQ and these were discussed in feedback sessions shortly after the lessons. As soon as possible, DVDs of the lessons were sent to participants for further reflection. Participants were asked to complete regular written reflections on their mathematics teaching in relation to the KQ. Eight of the nine teachers remaining in the study met together at the end of the year to discuss the impact of this project on their teaching.

## **THE CASE OF AMY**

### **Foundation knowledge revealed during Amy's training year**

The lesson observed during Amy's training year was with a reception class (4-5 year olds). This lesson was about counting from 0 to 20, with a focus on recognising and writing numbers between 10 and 20. Gelman and Gellistel (1978) proposed that in order to count meaningfully children need to know the number names in order, understand one to one correspondence, and recognise the cardinal principle i.e. that the last number said in a count is the answer to the question 'how many?'. They also suggested that in order to teach children to count effectively it is important to know the order in which children attain these pre-requisites. Amy showed some useful pedagogical content knowledge in relation to these pre-requisites for counting. When asked if she remembered what children need to know in order to be able to count, Amy responded that "It's number names and order" and went on to say "It's not anything to do with cardinality or anything yet, it's just the rote, the reciting of numbers". She seemed to recognise that she was addressing a specific aspect of what children need in order to count, and deliberately didn't include the cardinal principle. When asked explicitly whether she had thought about this in her planning she replied "I think I had, 'cus on my plan I wrote down the objective for that, so I think I had".

Though observation of her lesson had suggested that Amy did not recognise the difficulty children have in writing numbers between 13 and 20 (the 'teen numbers'), the video-stimulated discussion showed that she did have this understanding and might make use of it in the future. Amy suggested that she should have concentrated more on the 'teen numbers' and demonstrated that she recognised that writing these is more difficult than other two-digit numbers:

Because you say the nine first then you say the teen (in 19), that's why often they write the nine first, then they do, but you see with Rosanna, she was writing ten, she wanted to write the zero first then write it from right to left instead of left to right.

During a ‘writing numbers game’ used as part of her interactive teaching input, Amy appeared to focus on correcting mirror images of single numerals rather than on the wrong ordering of the digits in a number. I pointed this out to her and asked whether she thought that this had been the most useful focus. After some discussion, Amy seemed to change her thinking on the relative importance of focusing on numeral reversal:

But now, thinking about it, I don’t know how important it is to work on reversals because often it’s just the fact that they haven’t seen enough numbers written, really there’s not that many up around the classroom.

One aspect of the foundation dimension that came out strongly in discussion with Amy about this lesson was her beliefs about the way in which mathematics should be taught to young children. When asked about her focus for the lesson, Amy became quite agitated:

I don’t know, this is what I was thinking about when I was planning it, and today as well ‘cus I felt really frustrated that I had taken this objective from the strategy<sup>1</sup>. But I was thinking, it’s not really what I agree with in a way ... it’s not how I normally teach either, I normally teach in a much more playful way with real context and a shop out and everything.

This strength of feeling about how mathematics should be ‘taught’ to young children is an issue that recurs in discussions with Amy. During the whole group meeting at the end of her training year she again suggested that she felt she had not been teaching in a way that reflected her beliefs:

It [reflecting on her lesson using the KQ framework] made me think more conceptually about what I was teaching, I suppose, yes like ... not focusing on resources but it made me think about, I’ve got certain priorities about early education, children’s mathematical development maybe conceptually, but that wasn’t coming through in the actual, lots of the lesson I was teaching, it was a kind of disparity between what I actually believe and what I was teaching in a way.

### **Foundation knowledge revealed during Amy’s first year of teaching**

Amy’s first teaching post was also in a reception class and I observed two lessons during this year. The first was another lesson on counting and the second involved measuring lengths using non-standard units.

My observation of the first of these lessons clearly demonstrated that Amy was using her knowledge of the pre-requisites for counting that had been apparent in our discussion of her training year lesson. Throughout the lesson she made these explicit to the children and reminded them of strategies, (put objects in a line, point to or

---

<sup>1</sup> The National Numeracy Strategy Framework for Teaching Mathematics (1999) for England and Wales sets out objectives indicating what children should learn in each year of elementary (primary) school.

touch each one only once), to use in order to be able to count. Her planning of the lesson would seem to have been based around this knowledge and this was confirmed during the discussion:

Yes I planned it from that framework<sup>2</sup> really, of that progression of saying the numbers in order, being able to do one to one correspondence and then the cardinal principle.

Amy seemed to recognise that a common error children make when counting is “not knowing when to stop”. She reminded children that they should stop counting when she stopped hitting the chime and that the last number is the answer to ‘How many?’ In the post-lesson discussion, Amy demonstrated that she was aware of this difficulty:

Well I picked Katy ‘cus she often, well when she started she would count things and then she would get to the last thing and then you would say ‘How many?’ and she would start counting again. She didn’t have like the cardinal principle ... that’s why I asked ‘How many are there?’ instead of saying ‘yes there’s seven’.

Amy’s lesson on measuring demonstrated an awareness of what is involved in the use of non-standard measures as well as of the common problems encountered by children. When working with children using shoes for measuring she reminded them to make sure they started at the beginning, that the shoes were touching and to count all the steps. Amy also addressed the problem of what to do with ‘the bit left over’. At the end of this session she demonstrated that the answer to ‘how many shoes’ will be different if the shoes are not the same length. However, the way in which Amy asked the children to use the shoes in this lesson suggested that she had missed a stage in the understanding of measurement. I suggested to her that it might have been useful to have begun by setting out shoes over the whole length of an object and then counting them before moving on to ‘stepping’. Amy explained that this had been on her plans for the lower achieving children though she had not done it. Amy also explained that this had been discussed with the other reception teacher and that they had decided that it would be difficult for the pragmatic reason that they did not have a large number of identical shoes.

Amy’s belief that learning mathematics should be enjoyable, which was apparent in her training year, was also a key feature of both these lessons. The use of brightly coloured boxes and interesting items, as well as a pirate ship context, employed in the lesson on counting were testimony to this. In the post lesson discussion, Amy explained her thinking behind the use of the coloured boxes:

The boxes activity, I planned that because I thought it would be nice to have an element of surprise, ‘cus counting, I don’t want it to be boring, too boring.

---

<sup>2</sup> Here, Amy’s use of the term ‘the framework’ referred to the *knowledge quartet framework*. She was suggesting that in planning her lesson she had thought about what *foundation* knowledge would be helpful in promoting learning in the children.

The use of story and practical activity using real objects in the measurement lesson also reflected Amy's concern for the affective domain of learning mathematics.

In addition to her concern for children to enjoy their mathematics, Amy also demonstrated that she believed they should understand the purpose of mathematics. Amy had concluded the introduction to the counting lesson by asking the children to put different sized coloured boxes in order, relating to the number of objects inside each one. During the post-lesson discussion I commented on the children's ability to do this, which prompted Amy to criticise herself for having forgotten to get the children to write the numbers of items inside them:

Yes, but I forgot to put, could have done, I planned to put a 'post-it'<sup>3</sup> on and get someone to write the number on. I forgot to do that ... would have given them a reason for why we write numbers and why we record so we can remember how many. And it would have been practice of them writing numbers. Or they wouldn't have had to write the numbers. They might have wanted to do five lines, think of their own way of recording.

In early July 2006, eight of the nine teachers remaining in the study met at the university to discuss their mathematics teaching, and particularly how participation in this project had influenced their teaching. Amy was one of this group and her contributions gave some interesting insights into her development particularly in relation to the *foundation* dimension of the KQ.

Amy's ability to teach in a way that reflected her beliefs appeared to have been mediated by the context in which she was teaching. Amy talked about how her present context supported the way she wishes to teach:

... I am not as constrained I think as I was on my placement. I was in a way given quite a lot of freedom to teach how I wanted, but I did feel constrained by the way the environment was set up in that reception class. (It) was really like formal and there wasn't as much play as how I would like to teach. In my school now it is totally different; it's like how I want to teach. The other teacher in reception is totally like-minded with me, we use lots of practical objects and it's more like how I want to teach.

At one point in the discussion I suggested starting from children's own understandings rather than teaching a progression of 'teacher-determined methods'. Amy gave an example of her teaching that demonstrated how she had given children opportunities to develop and show their own thinking:

With mine, actually the other day we were reading a story. We all got on our train with masks and pictures and (I asked) if a few more animals got on how many would be on the train? They had to show on their white boards how they were working it out which was quite hard ... It was so interesting, some children showed people on the train and they crossed them out or put ... on. Some children wrote numbers. One, say there were five on the train already and three more got on – they did 'one, two, three, four, five' and then

---

<sup>3</sup> A post-it is a small self-adhesive piece of paper that may be used as a label

they draw a hand to go ‘six, seven, eight’. They hadn’t actually put five in their head they started counting from one up to five and then gone ‘six, seven, eight’ on their fingers.

This suggested that Amy valued children’s thinking and was able to use their responses to understand the strategies they had employed. Amy recognised that the children’s working was at the ‘count all’ stage and they were not yet using ‘count on’ strategies (Gray, 2003). Later, she again indicated an understanding of individual ways of thinking: “Children think about things in different ways don’t they some children prefer to see the numbers as a square .... Or some children pick up objects”.

Later in the discussion, I suggested that rather than focussing on teaching specific methods, an alternative would be to set problems and help the children to develop the methods they came up with to solve these. Amy demonstrated that she was open to this approach and gave an example of how she had employed it in her teaching:

It was a story called ‘Shrimp’, a Caribbean counting book and there was a big sister and a little sister in it and they had lots of different fruits, and like the big sister had one and the little sister had none. So we had a fruit hunt, and I had nine and a child had one and we had to give them out in different ways. And then they worked in pairs and they had ten fruit and they had to find different ways of giving out their bananas. And we found the number bonds to ten.

During the group discussion, Amy’s belief that mathematics teaching should be relevant, practical and enjoyable was reflected in a number of her contributions. In a discussion of differences between the teaching of number and other aspects of mathematics, Amy commented: “You need more practical often and relates more to the maths doesn’t it”.

I asked the group if they ever thought about ideas given in mathematics sessions during their university training, when planning and teaching. One participant said that she did remember, and used the principles for counting as she has written an assignment<sup>4</sup> about this. Amy agreed with this and her response again reflected her belief that mathematics teaching should be concerned with the affective as well as cognitive aspects of learning:

... and you can relate loads of things from that (the assignment), you can relate loads of principles or things that work from that essay. Mine was a role-play activity; you know the book ‘Each Peach Pear, Plum’. I made a role-play area of the kitchen from ‘Each Peach Pear, Plum’. So my activity was going on a picnic, making a picnic in the role-play-area and that was a counting activity. But it relates to so many areas and I ... and um problem solving and also the principles of counting that child have to go through.

---

<sup>4</sup> In the first term of their training year, students were required to write a mathematics assignment that focused on analysing what children’s responses to a mathematical activity revealed about their understanding. Reference to relevant reading about the area of mathematics discussed was a requirement of this assignment.



I reminded the group that when they were doing the course, trainees would often comment that calculation methods taught in school today make a lot more sense than those they had learned. I suggested that research (Brown Mcnamara, Jones and Hanley, 1999) shows that once in post, teachers often revert back to the methods they learned in school. I asked if they thought this might be the case for them. Amy's response to this was to talk about her own lack of confidence in mathematics, and a worry that she might be teaching children incorrectly:

When I am planning my literacy, because that's my subject, I can have it like clear in my head, really clear, like how I want to make the links between maybe the introduction and the end of the lesson. And it joins together really easily. So with maths, even in reception, it is really simple really but I still worry that I am giving misconceptions just by being slightly confusing in my wording or something. I am not sure because it is kind of ... that's my problem.

She went on to say that "I just hardly remember any maths at all, I can't remember anything."

## DISCUSSION

The evidence from just three lessons provides few possibilities for direct comparisons of revealed content knowledge from one lesson to another. However, the two lessons on counting do offer one such opportunity. After the first lesson, Amy was able to give some of the pre-requisites for counting and 'thought' that she had been conscious of these when planning the lesson. When discussing the second lesson on counting, Amy was much clearer about the pre-requisites and explained that she had quite explicitly used these when planning and teaching her lesson. In this respect, her *foundation* knowledge would seem to have become more secure. It might be conjectured that this was the direct result of Amy's reflections on her lesson, facilitated by discussion which used the KQ framework to focus on content knowledge.

The three lessons offer a number of instances in which Amy's reflections appear to develop her content knowledge. Discussion of the first 'counting' lesson seemed to clarify Amy's understanding of why teen numbers are so difficult for children to write, and helped her in developing a position on the importance of correcting numeral reversals. Discussion of the second 'counting' lesson enabled Amy to reflect on the reasons for encouraging children to use emergent symbols (Gifford, 1990) for recording numbers of objects. In discussing the lesson on measuring, Amy seemed to realise the need for a stage when using non-standard units in which a number of uniform units are laid end to end before counting.

An aspect of foundation knowledge that came out strongly in all the discussions of Amy's teaching was that of 'awareness of purpose'. This would seem to be a reflection of her strong beliefs about the teaching of mathematics. Amy talked about the need for teaching to be practical and enjoyable when reflecting on all of her lessons. In the most recent group discussion she would seem to have developed this,

possibly naïve view, to a more sophisticated conception of mathematics teaching in which ‘problem solving’ and ‘starting from children’s understanding’ are important strategies. It could be argued that reflecting on the mathematical content of her teaching using the KQ had acted as a catalyst in this development.

When asked how taking part in this project had made her think about her maths differently from how she might have done otherwise, Amy responded:

“I found it, it does make you more reflective and it makes me, um from the transformation section I think it makes me think of examples I am going to use or the images really carefully .... and also planning even what things I might say or do or extra little activities like bringing something that works. I think about ways of planning, but what I have appreciated about it, I think, had been the way you have come in and given different possibilities for what I could have, different ways of structuring the lesson or different ... things I could have done. ... talking the feedback over with my colleagues we have had more of a dialogue about maths and our teaching of maths in school, well in the lower school with my colleagues, and that seems really interesting and useful it is always good to talk about other people’s ... about how you are teaching or about how you can move forward.”

Amy will continue, along with five others, to take part in this project for two further years. Discussions over first two years have helped all the participants to become familiar with using the KQ. In the next two years they will be expected to take a more pro-active role in using the KQ to reflect on their mathematics teaching and to reflect and report on their own development. Amy’s reflections focusing on the *foundation* dimension of the KQ would seem to have facilitated some development in her understanding of herself as a teacher of mathematics. She has recognised the importance of teaching in a way that is consistent with her beliefs about mathematics and mathematics teaching. Amy also seems to think more explicitly about the theory behind her teaching practices e.g. using knowledge of the pre-requisites for counting to plan her lesson. Despite having demonstrated a considerable degree of PCK, Amy continues to lack confidence in her own mathematics and her ability to effectively teach this subject to young children. It will be interesting to see whether her perceptions of herself as a mathematician and as a teacher of mathematics change as the project continues.

## References

- Ball, D. L.: 1990, ‘The mathematical understandings that prospective teachers bring to teacher education’. *Elementary School Journal* 90, pp. 449-466
- Brown, S. I., Cooney, T.J. and Jones, D.: 1990, Mathematics teacher education. In W.R. Houston (Ed) *Handbook of Research on Teacher Education* (pp. 639-656) New York: Macmillan
- Department for Education and Employment (DfEE): 1999, *The National Numeracy Strategy: Framework for teaching mathematics*, Sudbury: DfEE Publications

- Gelman, R. and Gallistel, C.: 1978, *The Child's Understanding of Number*. Cambridge MA: Harvard University Press
- Gifford, S.: 1990, Young children's representations of number operations. *Mathematics Teaching*, 132, 64-71
- Gray, E.: 2003, 'Compressing the counting process.' In I. Thompson (Ed.) *Teaching and Learning Early number* (pp. 63-72). Maidenhead: Open University Press
- Ma, L.: 1999, *Knowing and Teaching Elementary Mathematics: Teachers' Understanding of Fundamental Mathematics in China and the United States*. London: Lawrence Erlbaum
- Office for Standards in Education (OFSTED): 2000, *The National Numeracy Strategy: The First Year: A Report from HM Chief Inspector of Schools*. London: HMSO
- Rowland, T., Huckstep, P. and Thwaites, A.: 2003, 'Elementary teachers' mathematics content knowledge and choice of example' CERME 3: Third Conference of the European Society for Research in Mathematics Education. March 2003, Belaria, Italy
- Rowland, T., Huckstep, P. and Thwaites, A.: 2005a, 'The Knowledge Quartet: Considering Chloe' CERME 4: Fourth Conference of the European Society for Research in Mathematics Education February 2005. Sant Felue de Guixols, Spain.
- Rowland, T., Huckstep, P. and Thwaites, A.: 2005b, 'Elementary teachers' mathematics subject matter knowledge: The knowledge quartet and the case of Naomi'. *Journal of Mathematics Teacher Education*, (8) pp. 255-281
- Post, T. R., Harel, G., Behr, M. J. and Lesh, R.: 1991, Intermediate teachers' knowledge of rational number concepts. In E. Fennema, T.P. Carpenter and S. J. Lamon (Eds.), *Integrating research on teaching and learning mathematics* (pp. 177-198) Albany, NY: SUNY Press
- Schon, D.A.: 1983, *The Reflective Practitioner*, New York, Basic Books
- Wagner, J.: 1997, 'The unavoidable intervention of educational research: A framework for reconsidering researcher-practitioner cooperation.' *Educational Researcher*, 16 (7) pp. 13-22

## **TRAINING MATHEMATICS TEACHERS IN A COMMUNITY OF LEARNERS (COL)**

N.C.Verhoef & C. Terlouw

University of Twente

*In the Community of Learners (CoL), trainee teachers learnt to discuss scientific articles concerning the didactics of mathematics. The trainer explained theoretical issues with, coincidentally or consciously, trainee teacher's class-experiences. All the teachers integrated the delivered theory into their lesson preparations at school. However, in the class, the reality of school life came as such a shock that the trainee teachers were no longer able to conduct the planned educative discussions aimed at developing mathematical understanding. Appraisals revealed that the main issue was a combination of the straightjacket imposed by following the book and the culture of working independently. It would be advisable to enrich the CoL arrangement with the concrete participation of qualified teachers.*

### **INTRODUCTION**

The reality of mathematics education in the Netherlands is that the teacher is becoming less a conveyer of knowledge and more a supervisor of pupils' learning processes. The question is how teachers can directly and positively influence learning processes in order to adequately prepare pre-university pupils for scientific or technical studies. This is necessary because of the decreasing student input for mathematics in the Netherlands. Furthermore, Dutch teaching methodologists indicate a shortage of fundamental mathematical comprehension in secondary education. They argue that abstract mathematical thinking should be promoted (Verhoef & Broekman, 2005). Furthermore, they advance the idea that reflecting on activities carried out by pupils would be a necessary improvement on current mathematical education (Simon, et al., 2004).

These recommendations are important for university teacher-training courses as that is where essential teacher competences can be acquired. Therefore, the general question arises how to improve the existing teacher training taking into account the discussion mentioned before. The purpose of this research is both theoretical and practical. The theoretical purpose is the contribution to a theory of pre-service teacher training concerning the impact of a CoL with characteristics that connects with the mentioned discussions on the expertise development of trainee teachers. The practical purpose is the integration of the didactic theories in the practical school-setting of mathematics in pre-university education. This paper reports about the application of the above mentioned teacher training characteristics in a CoL, focused on mathematics didactic theories, for a teacher trainer and trainee teachers mathematics in pre-university education, and the impact of this CoL on the theory-practice relations in the expertise of trainee teachers involved.

## **PROBLEM DEFINITION AND RESEARCH QUESTION**

The general problem can be defined as whether a CoL, in which mathematics didactic theories are the primary focus, contributes in a positive sense to the development of the trainee teachers' expertise. The research question is: How much influence does a CoL have on the intended professional and didactic competences concerning the relations trainee teachers make between (1) delivered mathematics didactic theories and (2) the everyday school-setting during their first school-based work experience? Taking into account the theoretical and practical research purpose the teacher training approach has the following characteristics:

- (1) Teacher training is closely related to the actual school-setting. In the first half year trainees have a little bit of practical experiences of an oriental character. Later on, trainee teachers actually deliver lessons, guide pupils in mathematical problem solving, construct examinations, etc. The actual school-setting is the starting point for the deliberations between the teacher trainer and/amongst the trainee teachers;
- (2) The role of the teacher trainer is to enrich theory by acting himself as a 'good practice example'. The teacher trainer demonstrates how to apply mathematical didactic theory in practical school-settings. By doing this, the teacher trainer also learns, especially because the application demonstration is critically discussed with the trainee teachers. The trainer and trainee teachers form a CoL;
- (3) Besides acquiring theoretical knowledge about learning mathematics, mathematical didactic communication will also be developed through a continual cycle of all experiences in the class, and reflection on these experiences. Trainee teachers and the teacher trainer(s) are both equally involved in the critical discussion of the experiences and reflections. This is important in a CoL;
- (4) The learning process for each trainee teacher is different. These differences can be employed to expand the learning process of other trainee teachers (Simon, 1995). These utilizing individual learning experiences are a feature of a CoL;
- (5) The last feature coincides with one of the aims of the training course. The intended aim of the training is also to develop a trainee's attitude as a researcher in classroom practices, parts of a complex school-environment. The trainee's research focuses on pupils' learning processes. Of course, such attitude and the experiences with a research perspective in classroom practices is a theme in the CoL. The teacher trainer's own research is an important input in this respect; and
- (6) The teacher trainer must apply congruent training in a CoL - "Teach as you preach!" – in order to prevent cognitive disharmony in the trainee teacher's mind.

## **THEORETICAL FRAMEWORK**

In this paper the central theme of teaching trainee teachers is the stimulation of pupils' learning processes particularly with regard to abstract mathematical thinking.

Taking into account the congruency principle, the process of abstraction is the leading process for the choice of the teaching approach for trainee teachers. As explained before, a CoL takes the actual school-setting as a starting point for a process of abstraction in order to relate this actual school-setting with mathematical didactic theories. The theory focuses on (a) a CoL as seed-bed for trainee teachers, and (b) a CoL as an option for congruent training of trainee teachers.

(a) a CoL as seed-bed for trainee teachers

The educational concept of a CoL is founded on exploratory learning; scientists learning from each other. Brown and Campione (1996) elaborated on this by carrying out research in small research teams, sharing results with fellow students from other research teams, and applying the knowledge acquired to new (consequential) tasks in which were integrated the findings from each of the separate research teams. Students participating in a CoL are therefore researchers who are expected to (1) listen to the teacher and consider how the teacher uses role models (as expert, model and coach) to demonstrate something, (2) listen well to each other, (3) be able to present results, and (4) be able to carry out subsequent steps in their research (Crawford, 2000). Brown and Campione's research findings suggest that active participation in an educational learning environment that accords with the principles of a CoL results in better understanding of field-specific knowledge and adequate application of general interpretation and reasoning strategies. Given the results, it seems important to consider whether the organisational features of a CoL are still relevant in the present trainee-teacher situation. To that end, these organisational features need to be interpreted and adapted to the trainee-teacher situation.

This pilot study does not cover an environment of researchers in the same way as Brown and Campione, but it covers an educational learning environment in which trainee teachers form, together with a trainer, a CoL. The trainee teachers are not carrying out research comparable to Brown and Campione, but are conducting teaching-related studies of the literature under the supervision of the trainer. The trainee teachers are referred to the literature by the trainer. They read and present the content to their fellow trainees. The underlying training goal focuses on a researcher's attitude: to ask questions, to observe the environment, to choose variables, to make a plan, to experiment, to analyse the results, and to reason exactly, validly and reliably with the results. The trainer is responsible for the supply of literature and the translation of this into the classroom setting. Under supervision of the trainer, the trainee teachers then employ their newly acquired knowledge to the search for and reading of subsequent articles. The aim is to jointly gain knowledge concerning the teaching of mathematics in order to be able to integrate adequately this knowledge in the practical school situation. Apart from a CoL as a nursery for training teachers, the approach also concerns the congruent training of trainee teachers.

(b) a CoL as an inevitable option for the congruent training of trainee teachers

The teaching concept of a CoL reflects congruent training. Swennen, Korthagen and Lunenberg (2004) are referring to ‘the didactic process of the teacher trainer in harmony with the didactic process that he or she wishes to promote in the (future) teachers’. Trainees (future teachers) not only hear how they should teach, but also experience personally how their trainer puts into practice, explains and underpins with theory the desired didactic process (Teach as you preach!). This approach is necessary because of a lack of trainee teacher’s classroom-practices. The trainer adds practical experiences to trainee teacher’s individual and group learning processes. Swennen, Korthagen and Lunenberg’s research findings illustrate the idea that the conscious use of congruent training can contribute to closing the gap between theory and practice.

In this pilot study, congruent training is geared to the active role of the trainer, who employs: (i) educative discussions with trainees and (ii) coaching skills to use heuristic methods to solve problems, in order to provide a model of the classroom situation in which these trainee teachers will guide pupils in the learning process. In such a situation, all participants are active, and each individual contribution is utilised positively. In the situation described here, the educative discussions concern, in terms of content, teaching mathematical concepts with a particular emphasis on teaching abstract concepts. Next, the teacher trainer demonstrates coaching skills in order pupils let apply heuristics methods for solving abstract math problems. This approach serves as a model for the teaching situation in the classroom setting. Trainee teachers are challenged at their own level to generalize and condense mathematical concepts.

## **RESEARCH METHOD**

The study consisted of a pre-test at commencement of the module and a post-test at conclusion. In the meantime, theory and practice were interwoven with the trainee teachers’ individual teaching experiences, their own school-based work experience and the trainers’ interventions. The questions in the pre-test indicate trainee teachers’ reference points about: (1) didactical knowledge of teaching and learning mathematics and (2) experiences with classroom-practices. The intentions of the trainee teacher become clear: what kind of math teacher do you want to be?

The questions in the post-test relate to the teachers’ role in the classroom setting with reference to discussed theory and trainers’ didactical remarks. The answers in the post-test were subsequently justified and explained, where if desired, via semi-structured interviews with each trainee teacher. In the sessions, (i) assignments about school mathematics were discussed in relation with theory and (ii) the stated literature was presented by the trainee teachers to each other. Taking into account the pre-test intentions, the development in professional and didactic competences becomes visible.

The trainer’s interventions focused on an attitude as a researcher. She stimulated to ask classroom-related questions, to observe the students’ learning processes, to choose an item as a variable, and to design a work plan. The trainer weaved the

discussion with situation related examples, and translated the theory discussed into classroom practices. On the basis of (subsequent) discussions with the trainer, new assignments concerning school mathematics were issued linked to other scientific articles or sections from books concerning mathematics teaching methodology. In the sessions, the trainer formed a role model by conducting educational discussions and by cooperatively finding solutions to mathematical problems. The reflection on trainee teachers' activities in terms of abstraction was a common theme. Every session concluded with concrete subsequent agreements for the following session.

## **MATERIALS AND TEACHER INTERVENTIONS**

Materials consisted of a website which included (links to) (inter) national articles. The sequence was from general epistemological and educational psychology literature to field-specific teaching-related literature. The theory ended with a look ahead to the particular mathematics didactic theory as a part of the more general didactic theory.

The assignment was that each participant in a lecture should present to the group an article allocated to her or him. Where possible, a concrete (school) mathematics assignment was connected. With respect to content, the emphasis lay on forming a cognitive structure. A cognitive structure consists of cognitive units that can be enriched by compression (simplification) and generalisation (generalizing). The strength of a cognitive structure is dependent on transfer between the units (Barnard & Tall, 1997). Based on this theoretical foundation the trainees used their knowledge to solve a student-level problem, for example: the 'square-triangle' problem from George Polya's *How to Solve it* (1957). The problem was as follows: Inscribe a square in a given triangle. Two vertices of the square should be on the base of the triangle, the other two vertices of the square on the two other sides of the triangle, one on each. The students prepared themselves to solve the problem at home within 20 minutes. They registered their efforts by video. At the university meeting none of the students had solved this problem. Therefore, the teacher trainer performed a congruent teacher's role. Polya's problem describes unknowns, given data and imposed conditions. The students didn't have any idea how to start the problem solving process. The teacher trainer encouraged one of the students to use the blackboard and asked him to construct a square that only satisfies the given conditions. The student drew such a square. None of the other students had a brain wave... The trainer asked the student to draw another one. None of the students had an idea how to go on... The trainer went on to ask to consider how the fourth vertex (i.e. the one not yet on the side of the triangle) would vary if more squares were drawn. One of the trainees had the insight to realize that the larger square was simple an enlargement of the smaller square, with the centre of the enlargement being the lower left-hand vertex of the triangle. Then the locus of the fourth vertex of the square was easily drawn and hence the point of intersection could be found. The trainer reflected on the problem solving process and challenged to prove these



findings formally. She emphasized alternative constructions and stimulates trainees' thinking processes. She attended on enrichments by a parallel line through the top of the triangle and the elongation of the intersection. She recommended to do further investigations using dynamic geometry software like Cabri or Cinderella. As a model the trainer influenced trainee's learning processes by hints and reflection on the answer and on the problem solving approach.

These experiences were the teacher trainer's foundation to discuss all sorts of rich cognitive units. The necessary transfer was illustrated using computation, structuring and demonstration. Learning to abstract progressed using statements for which the solution was not obvious. Trainees were allowed to help each other to find the correct solution. As a model, the trainer also sometimes underpinned the solution strategy aloud in order to encourage trainee teachers to undergo a process of awakening with regard to the teaching of mathematics concepts. This approach also brought the trainee teachers' isolated cognitive units to the surface. The trainer monitored the process to ensure that all participants remained constantly involved.

### **Participants**

The intake in the Communication and Education subsidiary subject consisted of ten trainees, five female and five male, and a trainer. The trainer, mathematically, professionally and educationally competent, functioned as product and process supervisor. She was responsible for the freely downloadable materials on the website, and the content-specific discussions during the sessions. The age, branch of study and work experience of the trainees differed greatly. Data collection took place using the following research instruments.

### **Data collection and research instruments**

The questions posed to the trainees in the pre-test concerned the trainee teacher's point of view to become a mathematical teacher. After listing previously attained skills, it related to written answers to the following questions: 'What kind of teacher do you want to be? The answers varied in characteristics of: knowledge, explanation, the use of ICT-tools like the computer, the graphic calculator, and the equations chart, employing solution strategies and heuristics, development of tests, practical assignments and profile projects.

The post-test consisted of reflective questions regarding the progress of the lessons given that were justified afterwards and explained in semi-structured interviews. The questions were: 'Did you made conscious use of the mathematics didactic theory delivered in your preparation, implementation and evaluation?' and 'If so, then how did you do that? What kind of result?' or 'If not, why was this a problem? What did you do to change the situation?'. The answers were to include statements specifically referring to the mathematics didactic theory delivered in the CoL as obtained personally by the trainee. The goal was, as said, to establish the influence of the CoL at trainees' learning process to become the intended mathematical teacher, to acquire

the intended professional and didactic competences (see research question). Besides the pre- and post-test, also the teacher trainer interventions – as a feedback reaction on the pre-test intentions of the trainee teachers - were recorded.

### Data processing and analysis

The pre-test, professional and didactic competences, contained trainees own intended mathematical teacher idea. The post-test consisted of a preparation, an implementation and an evaluation phase. The preparation phase concerned references to the cognitive structure that was part of the cognitive unit to be covered. In the implementation phase, the emphasis was on the transfer of the knowledge the trainees already had to the mathematical concepts to be covered. The educative discussions (or an analogue form of dialogue between trainee and trainer) were integrated in this phase. The evaluation phase was aimed at the generalisation and compression of mathematical concepts. The teacher trainer personal interventions were analysed and summarized.

### RESULTS

The results of the pre-test, the teacher trainer's interventions, and the post-test are given in tabular form including some comments.

*Pre-test results*, all trainees had an idea beforehand over the professional and didactic competences they aimed to develop during the trainee phase (see Table 1).

Trainee	The development of professional and didactic competences
1	To be able to use mathematics creatively, the links and analogies
2	Good preparation is essential for developing structure
3	No comments
4	Small pointers and a good structure
5	It is important to explain mathematics, good contact with pupils
6	Keep pupils' attention, keep motivating pupils
7	Explain and improvise, anticipate situations
8	Maintain professional skills, complete all sums beforehand
9	First answer pupils' questions, only then begin explaining new material
10	Extra attention for explanation, mathematics can genuinely be fun

Table 1: Results of the pre-test

The table demonstrates that explanation and offering a clear structure to pupils is very high on the list of priorities for trainee teachers. Motivation was also mentioned. One trainee teacher developed the thought further to her professional knowledge.

*Teacher trainer personal interventions*

The teacher trainer's interventions (advices, materials, textbooks, ICT-tools, puzzles, games, personal examples) varied depended on trainee's personality and trainee's school situation in practice. A summarized overview is depicted in Table 2.

Trainee	The teacher trainer's personal related interventions
1	Scan pupils' materials and integrate algebra and geometry
2	Execute all assignments and annotate securely the preparation form
3	Think about your future: what is your teacher's role in practice?
4	Mark highlights in reference to pupils' learning processes
5	Focus on pupils' entertainment besides all day school life
6	Concentrate on pupil's attitude in the classroom
7	Apply yourself to the background of mathematical concepts
8	Combine school mathematics with your own knowledge
9	First of all register exactly pupils' basic knowledge
10	Demonstrate mathematics as a motivated game

Table 2: Teacher trainer's personal related interventions

The table shows teacher trainer's efforts to integrate theory and practice.

*Post-test results*, an overview of the post-test results is depicted in Table 3.

Trainee	The outline of the preparation, implementation and evaluation phase
1	A lack of numerical understanding and algebraic skills
2	Inadequate (cerebral) calculation skills
3	No idea to activate individual pupils' groups learning processes
4	No knowledge of the use of graphic calculators in school practice
5	No experience with computer practices
6	No knowledge about pupils' life styles
7	Obstruction through own mathematical misconceptions
8	A lack of expertise in (school) mathematics
9	Insufficient skills about mathematical equations
10	A lack of transfer between different representations of mathematical concepts

Table 3: Results of the post-test

This Table shows that, despite plans to develop professional and didactic skills, none of the trainees had actually managed to establish a direct relationship between the theory delivered in the CoL and the classroom-setting during the trainee phase. It appeared that very little had come through of the teacher trainer's interventions.

Two trainees (1 and 5) indicated that they had conducted educative discussions and during the implementation phase with the emphasis on listening to each other. They used coaching skills to use heuristic methods to solve problems adequately. The others appeared not to be able to integrate theory and practice using the educative discussions, despite preparations in which the theory delivered actually took a dominant place. During further questioning in the semi-structured interviews that followed on the final report, the trainees suggested the following were the cause:

- the book offered too little room for input from students and teachers;
- the study planner was seen as a straightjacket limiting the pace of learning;
- the culture of doing assignments, where theory is replaced by carrying out assignments that are constructive in character, and also where each assignment builds further on previous assignments, does not, in this deductive structure, stimulate reflection on either section structure or assignment composition;
- the culture of working independently where the teacher functions as a coach;
- the trainees were frustrated to discover that the ideal education situation (the teacher is free to follow his or her own path based on theoretical knowledge) does not exist, and that the initial experiences are more geared to keeping order than to mathematics education. Finally, the trainees were able to indicate with theoretically substantiated arguments what went wrong and what they need to work on as a result;
- the two trainees who were able to conduct educative discussions did this on the basis of classroom experiences they already gathered. One had some teaching experience. The other had plenty of experience as a university lecturer.

## CONCLUSIONS AND DISCUSSION

It can be concluded that the trainees did manage to integrate the theory delivered in the CoL into their preparations, but did not manage this sufficiently in the implementation, and did not manage it at all in the evaluation. However, when requested to do so during the evaluation, they were able to integrate the delivered mathematics didactic theory into the reality of the classroom setting. When reflecting on the influence of a CoL as a nursery for trainees, they were unanimously satisfied with this approach. The working method explicitly prompted them to mutual cooperation in terms of content. They felt obliged to attend every session and actually offered their own contribution. Commitment was therefore outstanding. The programme's flexibility, the content in tune with their needs, appealed to them. Teaching in the reality of the classroom appeared to be more stubborn, and surprised and confused them. They had been too concerned with content in the CoL, and had not been practical enough. This means that everyday teaching reality must take a more central place in the CoL. This may be achieved by, for example, allowing a

different mathematics teacher to participate at each session of the CoL, or to make explicit the trainee-experience prior to participation in the mutual learning environment of a CoL.

In summary, the trainee teachers considered the CoL as a good working method, in which they felt stimulated to actively provide their own contribution and to cooperate intensively on content. The transfer to the classroom setting at school disappointed, because the reality was after all very different from what they had supposed, and there appeared to be little room for their own input into the lessons. This means that everyday teaching reality must emphatically be better integrated into the CoL.

## REFERENCES

- Barnard, T., & Tall, D., 1997: 'Cognitive units, connections and mathematical proof', *Proceedings of PME 21*, Finland, 2, 41– 48.
- Brown, A.L., & Campione, J.C., 1996: 'Psychological theory and the design of innovative learning environments. On procedures, principles, and systems'. In L. Schauble & R. Glaser (Eds.), *Innovation in learning: New environments for education*, (pp. 289-325). Mahwah, NJ: Lawrence Erlbaum Associates, Inc.
- Polya, G., 1957: *How to solve it*, Princeton University Press.
- Crawford, B.A., 2000: 'Embracing the essence of inquiry. New roles for science teachers', *Journal for Research in Science Teaching*, 37, 916-937.
- Simon, A., Tzur, R., Heinz, K., & Kinzel, M., 2004: 'Explicating a mechanism for conceptual learning: elaborating the construct of reflective abstraction', *Journal for research in mathematics education*, Vol., 35, 5, 305-329.
- Simon, M., 1995: *The development of thought equilibration of cognitive structures*, New York: Viking.
- Swennen, A., Korthagen, F., & Lunenberg, M., 2004: 'Congruent opleiden door lerarenopleiders', *VELON, Tijdschrift voor lerarenopleiders* 25, 20, 17 – 27.
- Verhoef, N.C., & Broekman, H.G.B., 2005: 'A process of abstraction by representations of concepts', *Proceedings of PME 29*, Norway, 4, 273-280.

## **EXEMPLIFICATION IN THE MATHEMATICS CLASSROOM: WHAT IS IT LIKE AND WHAT DOES IT IMPLY?<sup>1</sup>**

Iris Zodik & Orit Zaslavsky

Dept. of Education in Technology & Science

Technion – Israel Institute of Technology

*The main goal of the study reported in our paper is to characterize teachers' choice and use of examples in the mathematics classroom. For the purpose of this study, we developed in an iterative way, a multi-dimension categorization scheme. In our paper we focus on two of these dimensions, illustrate how they manifest themselves in the classroom, and examine what is entailed in some of the categories from the teacher's standpoint. In particular, we examine the nature of pre-planned examples vs. spontaneously generated ones, and identify three main situations involving construction of spontaneous examples. We discuss the potential implications of the findings to mathematics teacher education activities.*

### **EXAMPLES IN MATHEMATICS LEARNING AND TEACHING**

Examples are an integral part of mathematics and a significant element of expert knowledge (Michener, 1978). In mathematics learning, examples are essential for generalization, abstraction and analogical reasoning. Studies on how people learn from worked-out examples point to the contribution of multiple examples, with varying formats (Atkinson et al, 2000). Such examples support the appreciation of deep structures instead of excessive attention to surface features. Studies dealing with concept formation highlight the role of carefully selected and sequenced examples and non-examples in supporting the distinction between critical and non-critical features and the construction of rich concept images and example spaces (e.g., Vinner, 1983; Zaslavsky & Peled, 1996; Petty & Jansson, 1987). In spite of the critical roles examples play in learning and teaching mathematics, there are a small number of studies focusing on teachers' choice and treatment of examples. Rowland et al (2003) identify three types of elementary teachers' poor choice of examples, which concur with the concerns raised by Ball et al (2005) regarding the knowledge base teachers need in order to carefully select appropriate examples that are "useful for highlighting salient mathematical issues" (ibid). Not surprisingly, the choice of examples in secondary mathematics could be far more complex and involve a wide range of considerations (Zaslavsky & Lavie, submitted).

The use of examples presents the teacher with a challenge, entailing many considerations that should be weighed, especially since the specific choice of examples may facilitate or impede students' learning. Yet, most mathematics teacher education programs (at least in Israel) do not explicitly address this issue and do not

---

<sup>1</sup> This research was supported by THE ISRAEL SCIENCE FOUNDATION (grant 834/04, O. Zaslavsky PI).

systematically prepare prospective teachers to deal with the choice and use of instructional examples<sup>2</sup> in an educated way. Thus, we suggest that the skills required for effective treatment of examples are obtained mostly through one owns teaching experience. It follows, that there is much to learn in this area from experienced teachers. Our study proposes to make a step towards learning from experienced teachers – their strengths and difficulties associated with exemplifications in the mathematics classroom.

## **TEACHERS' KNOWLEDGE ABOUT EXAMPLES**

There is interplay between the knowledge base that a teacher needs in order to construct useful instructional examples (e.g., Ball et al, 2005) and the knowledge that is reflected through his or her use of examples. In our study we address this interplay.

Based on Shulman (1986), we focus mainly on teachers' mathematical content knowledge, pedagogical content knowledge related to exemplification in mathematics, and knowledge of students' epistemology. Treatment of examples heavily relies on all the above three types of knowledge. From a mathematical perspective - an example must satisfy certain mathematical conditions depending on the concept or principle it is meant to illustrate; from a pedagogical perspective – an example needs to be presented in a way that conveys its 'message'; and from an epistemological perspective – it is necessary to be aware of what the students actually 'see' in an example (Mason & Pimm, 1984) and of the danger of over-generalizing or under-generalizing from examples.

As mentioned above, most of the knowledge related to instructional examples is gained through teachers' practice, thus constitutes craft knowledge (Kennedy, 2002). Teachers' craft knowledge is acquired mostly over time through their experiences; to a large extent it is a-theoretical and idiosyncratic (Kennedy, 2002). By making sense of mathematics teachers' craft knowledge regarding treatment of examples we hope to gain insight into specific aspects of their knowledge that may be used as a basis for designing professional development activities that may facilitate teachers' construction of systematic knowledge.

## **THE STUDY**

*Goal:* The main goal of the study is to characterize teachers' choice and use of examples in the mathematics classroom.

The participants of the study were five experienced secondary teachers (at least 10 years of math teaching). The research is an interpretive study of teaching that follows

---

<sup>2</sup> We use the term 'instructional example', to refer to any example offered by either a teacher or a student within the context of learning a particular topic

a qualitative research paradigm, based on thorough observational fieldwork, aiming at making sense and creating meaning of teachers' practice.

In order to address the goals of the study, we developed in an iterative way, a multi-dimension categorization scheme that enabled us to characterize teachers' use of examples. This was developed by observing 54 lessons of 5 different teachers. Altogether 15 groups of students were observed, 3 seventh grade, 6 eighth grade, and 6 ninth grade classes. The classes varied according to their level – 7 classes of top level students and 6 classes of average and low level students. The findings reported in this paper are based on the analysis of the above classroom observations.

*Data Sources:* We observed both randomly and carefully selected mathematics lessons of 5 experienced secondary mathematics teachers. By 'carefully selected' classroom observations we refer to observations of 'best cases', that is, lessons which the teacher considered to illustrate a particularly good way of example use in the classroom.

Pre and post lesson interviews were conducted with every teacher for each selected lesson. In addition, we collected relevant documents and the researcher managed a research journal.

## **FINDINGS**

### **The categorization system**

Our analysis of mathematics teachers' treatment of examples led to several criteria by which to characterize the nature and use of examples in the mathematics classroom. In this paper we focus on two: 1. The degree of teachers' planning of an example in advance (an example can be fully planned in advance or it may be spontaneously recalled or generated in response to an authentic need that arises in the classroom); 2. The type of mathematical entity (idea/principle) that the example is set to illustrate (mostly: a concept, a theorem, or a procedure/algorithm);

### **Teachers' degrees of planning examples**

An example a teacher presents in the classroom may be pre-planned in advance or one that he or she needs to construct on his or her feet at the spur of the moment upon some sort of demand. It may also be some combination of the two. It need not be strictly pre-planned or strictly spontaneous. Often a pre-planned example is modified spontaneously in response to a classroom situation that requires it. Teachers' ways of dealing with the need to spontaneously construct or modify an example is particularly interesting, because it indicates the immediate association they hold concerning the relevant body of knowledge with respect to examples. Along this dimension we identified some problematic classroom situations that occurred as a result of the teacher's need to generate an unexpected example. We turn to finding related to the degree that teachers plan their instructional examples. It should be noted that the more spontaneous examples provide us with insights to the underlying processes of



generating them, while the pre-planned ones are serve more as final products of teachers' thinking.

### *Teachers' generation of spontaneous examples*

Generation of spontaneous examples occur mainly in response to students' queries or suggestions. Sometimes teachers feel the need to provide additional or different examples if they realize that students have not grasped the main ideas or that the goal of the lesson has not been achieved. We identified such situations in the context of the lesson observed. Support to these situations we found through teachers' utterances, length of time elapsed, hesitations, or body expressions. For example, in one of the lessons a teacher said: "I'm trying to construct a simple example but it's not working."

We identified three main situations involving spontaneous examples: 1. Construction of a seemingly appropriate/correct example; 2. Construction of an 'example' that does not exist (i.e., has contradicting elements); 3. Construction of an example that does not seem to serve its intended purpose.

### *Example 1: A seemingly appropriate spontaneously constructed (counter-)example*

In a geometry lesson introducing the concept of a median of a triangle, the teacher used the following example (Figure 1(a)) to illustrate a median:

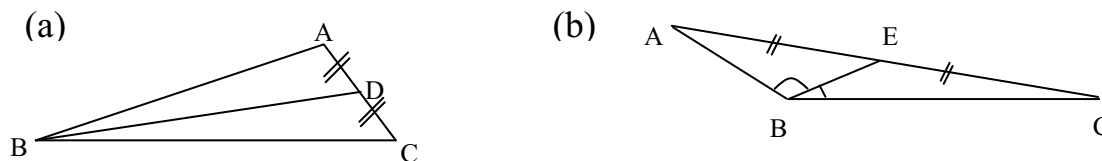

Figure 1: (a) The teacher's initial pre-planned example of a median; (b) The teacher's spontaneous modified example of a median

Based on this example, a student suggested that any median is also an angle bisector:

Student: If it [the median] bisects the side of the triangle then it must also bisect the angle, right?

Following the student's remark, the teacher modified the original example and presented the following case (Figure 1(b)):

Teacher: Not necessarily. Here you can see even without a protractor which of the angles is the largest.

The modified example seems to address the over-generalization of the student. Since in the initial example the median appeared to bisect the angle, the teacher modified it so the median no longer looks like an angle bisector. This spontaneous reaction of the teacher reflects his attentiveness to the student's attempt to over-generalize from the initial example. Moreover, the teacher's modification reflects a pedagogically appropriate response – in the new example the median no longer looks like an angle bisector. It is actually a counter-example to the student's wrong conjecture.

It should be noted that from a mathematical perspective both examples are problematic. The initial example looks like a non-isosceles triangle in which the median is an angle bisector. If this is what the teacher meant in his sketch – it is a case that does not exist. The modified example may exist, but the way the teacher treated it does not provide any logical support for its existence.

*Example 2: A spontaneously constructed example that does not exist*

Sketching examples that do not exist often comes to play when a teacher needs to come up with an example that illustrates certain properties, overlooking other irrelevant ones. There is a tension between accuracy and timely responsiveness to classroom needs. Sometimes it is impossible to check on the spot, for instance, whether all the givens of a specific (example of a) triangle co-exist and satisfy the necessary conditions of a triangle. The following example illustrates this point.

In a geometry lesson dealing with properties of an isosceles triangle, the teacher spontaneously chose the following example of an isosceles triangle (Figure 2) and asked the students to find the rest of the measurements of angles and sides of the triangle:

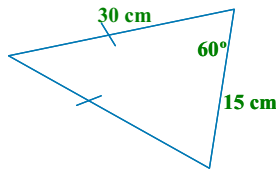

Figure 2: The teacher's spontaneous example of an isosceles triangle

This led to much confusion:

Student: But how can this be? If it's an isosceles and we got  $60^\circ, 60^\circ, 60^\circ$ ?

Teacher: You're right. I chose a value for the angle but didn't check what the third side should be.

It appears that while constructing this example the teacher attended separately to two systems of requirements: He knew that in the case of an isosceles triangle, given the measurements of the base and of one leg the other one can easily be determined; he also knew that in an isosceles triangle, given the measurement of any angle, the other two can be inferred. However, in the process of spontaneously constructing an example, he did not attend to the need for consistency between the two sets of conditions.

*Example 3: A spontaneously constructed example that does not serve its intended purpose*

In an algebra lesson the teacher chose [on his feet] the following quadratic equation to illustrate how to apply the Viète formula:  $2x^2 + 4x + 5 = 0$ .

As he started to illustrate it, he noticed that this was not a good example for this purpose. He then said:

Teacher: This equation doesn't have [real] roots; this example just came to my head; let's look at one with roots:  $x^2 + 5x + 4 = 0$ .

This example illustrates the flexibility the teacher needs in switching from one example to another, in order for it to serve the intended purpose. It seems as if the teacher wanted to give a sense of arbitrariness in selecting the first example, but didn't check the necessary conditions. However, once he became aware of the constraints he came up with a simple well-known equation for which he knew for sure that there were 2 real roots. It was an example he often used in order to illustrate the factorization of a trinomial.

### **What is exemplified?**

Our findings point to three main mathematical entities that teachers attend to through their treatment of examples. The most common practice has to do with repeated examples of how to carry out various procedures, e.g., solving linear or quadratic equations. These so-called examples are actually practice exercises, and are very rarely referred to by the teacher or textbook as examples at all. The more interesting uses of examples were identified in the context of concept learning, where some teachers were aware of the need to present not only examples of a concept but also non-examples of it (Wilson, 1990; Petty & Jansson, 1987; Charles, 1980). We illustrate this approach later (Example 4). In addition to concepts, teachers often deal with theorems, mostly in geometry lessons. In the context of dealing with theorems, teachers often deal with examples that satisfy the conditions of a theorem, and thus infer its conclusion. Yet, occasionally the need arises to come up with a counter-example that falsifies the theorem. We provide an example that illustrates what could be entailed in such a situation (Example 5).

#### *Teachers' use of non-examples*

As mentioned above, some teachers exhibited attendance to the use of non-examples when teaching new concepts. This approach is in concurrence with the literature related to concept learning that addresses the significance of refining one's understanding of a concept by examining 'close-misses', that is, non-examples of the concept that satisfy most but not all the conditions of its definition (Wilson, 1990; Petty & Jansson, 1987; Charles, 1980). By examining such cases, attention is drawn to critical features that may not be noticed otherwise. In the following example we illustrate how a teacher attempts to incorporate a non-example of a kite, when teaching this geometric concept. However, while altering certain constraints she failed to notice that the example she constructed is a special case of a kite, thus, cannot serve as a non-example.

#### *Example 4: What might be entailed in generating a non-example?*

In a geometry lesson introducing the concept of a kite, the teacher gave the definition followed by a drawing of a classical kite (Figure 3 (a)).

The teacher held the definition of a kite as a quadrilateral that is composed of two isosceles triangles sharing the same base. In her attempt to construct a non-example of a kite, she wanted to alter the position of one of the isosceles triangles, so they do not share a common base. Thus, she then drew the following ‘non-example’ (Figure 3 (b)):

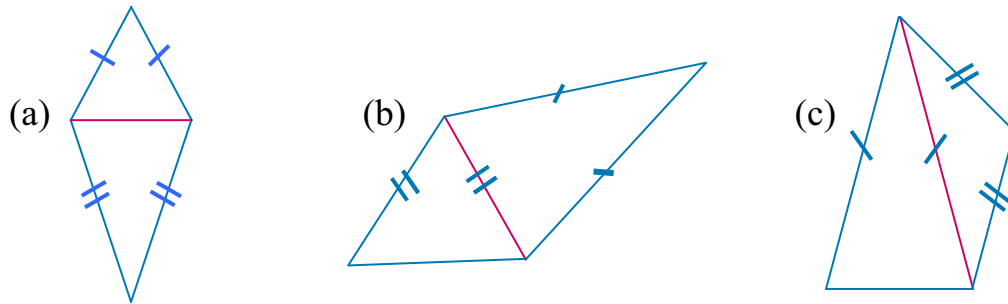

Figure 3: (a) The teacher’s initial example of a kite; (b) The teacher’s original ‘non-example’ of a kite; (c) The teacher’s modified non-example of a kite

However, a student called her attention by commenting:

Student: You drew by mistake an equilateral triangle!

The teacher realized right away that her example was not perceived as a non-example, and instead constructed another non-example (Figure 3(c)):

It should be noted that the second example (Figure 3(c)) is very similar to the first (Figure 3(b)). The main difference is the relative magnitude of the legs of the isosceles triangle compared to its base. It was important to draw both isosceles triangles in a way that they do not appear similar to an equilateral triangle.

This raises a central issue associated with visual/geometrical examples. Our findings point to much ambiguity surrounding the use of visual examples, in terms of what can be inferred from them and what not.

#### *Teachers’ use of counter-examples*

Teachers often encounter a situation where a student makes a claim that can be falsified, and in order to convince the student of his error the teacher needs to construct spontaneously a powerful counter-example (Example 1 illustrates such a situation). The following example illustrates how the process of constructing a (counter-)example may be a learning opportunity for the teacher.

#### *Example 5: What might be entailed in generating a counter-example?*

In a geometry lesson dealing with the SAS congruency theorem, students were asked to determine for a number of pairs of triangles whether they are congruent according to SAS. Figure 4 is a pre-planned textbook example that the teacher used in the classroom:



Figure 4: A textbook (pre-planned) example of a pair of triangles sharing 3 measurements

- Teacher: Are they congruent according to SAS?
- Student: In both of them there isn't SAS.
- Teacher: But are they congruent or not?
- Student: Yes they are.
- Teacher: I can give you a counter-example and show you that they are not congruent. There are actually an infinite number of counter-examples.

The teacher made the following construction (Figure 5), however, as she was doing it she expected to have many possible triangles, and noticed that there was just "one more":

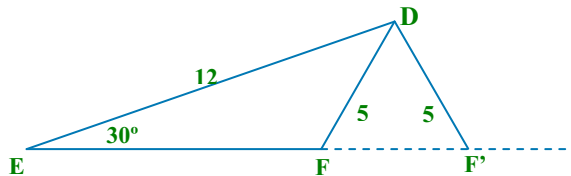

Figure 5: The teacher's spontaneously constructed counter-example

- Teacher: I have an infinite number of triangles. Wait, no, I don't – I only have 2 that are not congruent.

This classroom excerpt illustrates how a teacher constructed 'on her feet' an appropriate example in response to a student's assertion. It also illustrates how this process led to the teacher's refinement of her knowledge.

There are other issues that this example raises: In fact, in a way, the student rightfully regarded the two given triangles as congruent, since these particular triangles from the textbook (Figure 4) are actually identical. Judging by the two angles  $\angle DFE$  and  $\angle BAC$  in Figure 4, that are both obtuse, it appears that both of them are congruent to  $\angle DFE$  in Figure 5, and that  $\angle BAC$  is not congruent to  $\angle DF'E$ , as implied by the teacher. This classroom event reflects the complexity of analyzing teachers' use of examples, and how focusing on one aspect is not enough. To make this point even stronger, note that none of the triangles in Figure 4 and Figure 5 exist.

## DISCUSSION

In this paper we chose to present just two of the dimensions we identified for characterizing mathematics teachers' treatment of examples. Each dimension provides a lens through which to examine a mathematics lesson. In addition, we were able to identify some interconnections between these two dimensions. The findings point to

the connection between the degree of planning an example and the type of example. The more spontaneous examples provide insights to the underlying processes of generating them, while the pre-planned ones serve more as final products of teachers' thinking.

Our findings point to two main reasons for teachers' need to create examples spontaneously 'on their feet': (i) as an answer to a specific question that students raise; (ii) as the teacher's way of dealing with his or her recognition of certain limitations of a pre-planned example in the course of the lesson (e.g., the teacher may realize that more examples of the same kind are needed).

For instance, all the counter-examples that we observed were spontaneously constructed by the teacher in response to a student's unexpected invalid conjecture/statement. Thus, all the cases in which a teacher dealt with a counter-example were spontaneous, as a result of a classroom situation that called for it. As shown in examples 1 & 5, this requires sound mathematics knowledge. Interestingly, in all the classroom observations we conducted, there was not one instance in which a teacher pre-planned to deliberately incorporate a counter-example in the lesson.

The study sheds light on the complexity and problematic aspects involved particularly in geometric examples that are represented as sketches (opposed, for example, to accurate constructions with a compass and ruler). It is often not clear what visual information entailed in the sketch is relevant and what not or what can be inferred and what not. This often leads to a mismatch between the teacher's intention and what students actually notice and attend to (Mason & Pimm, 1984). We observed many cases of ambiguity that teachers convey with respect to the extent to which one can rely on a sketch: what are we allowed to infer from a sketch and what not?

The numerous episodes we observed form a rich source of cases that we are beginning to adapt for teacher education programs, both pre-service and in-service. This can be useful in providing systematic learning opportunities for teachers in order to facilitate both practical and theoretical knowledge of treatment of instructional examples. Along this line, it is recommended that teachers encounter systematic experiences in generating examples spontaneously for (real or hypothetical) classroom situations and reflect on them. Our experience with in-service and pre-service teachers indicates that such encounters provide rich and powerful learning opportunities that lead to teachers' deeper understanding of mathematics (e.g., of certain mathematical concepts), an expansion of their personal example spaces, and their awareness to different aspect of creating and choosing examples in mathematics.

## REFERENCES

Atkinson, R. K., Derry S. J., Renkel A., & Wotham, D.: 2000, 'Learning from Examples: Instructional Principles from the Work-Out Examples Research'. *Review of Educational Research*, 70(2), 181-214.

- Ball, D., Bass, H., Sleep, L. & Thames, M.: 2005, 'A Theory of Mathematical Knowledge for Teaching'. *Paper presented at a Work-Session at the 15th ICMI study conference on The Professional Education and Development of Teachers of Mathematics*, Brazil.
- Charles, R. I.: 1980, 'Exemplification and characterization moves in the classroom teaching of geometry concepts'. *Journal for Research in Mathematics Education*, 11(1), 10-21.
- Kennedy, M. M.: 2002, 'Knowledge and teaching [1]'. *Teachers and Teaching: Theory and Practice*, 8, 355– 370.
- Mason, J., & Pimm, D.: 1984, 'Generic Examples: Seeing the General in the Particular'. *Educational Studies in Mathematics*, 15, 227- 289.
- Michener, E. R.: 1978, 'Understanding Understanding Mathematics'. *Cognitive Science*, 2, 361-383.
- Petty, O. S., & Jansson, L. C.: 1987, 'Sequencing Examples and Nonexamples to Facilitate Concept Attainment'. *Journal for Research in Mathematics Education*, 18(2), 112.
- Rowland, T., Thwaites, A. & Huckstep, P.: 2003, 'Novices' Choice of Examples in the Teaching of Elementary Mathematics'. In A. Rogerson (Ed.), *Proceedings of the International Conference on the Decidable and the Undecidable in Mathematics Education*. (pp. 242-245). Brno, Czech Republic.
- Shulman S. L.: 1986, 'Those Who Understand: Knowledge Growth in Teaching'. *Educational Researcher*, 5(2), 4-14.
- Vinner S.: 1983, 'Concept Definition, concept image and the notion of function'. *Int. Journal of Mathematical Education in Science and Technology*, 14, 293-305.
- Wilson, S. P.: 1990, 'Inconsistent Ideas Related to Definitions and examples'. *Focus on Learning Problems in Mathematics*, 12(3 & 4), 31- 47.
- Zaslavsky, O. & Lavie, O. (submitted). 'What is entailed in choosing an instructional example?'
- Zaslavsky, O. & Peled, I.: 1996, 'Inhibiting Factors in Generating Examples by Mathematics Teachers and Student-Teachers: The Case of Binary Operation'. *Journal for Research in Mathematics Education (JRME)*, 27(1), 67-78.